

Manuscript Number:

Title: Continuous process for selective metal extraction with an ionic liquid

Article Type: Full Length Article

Keywords: ionic liquid; continuous process; selective metal extraction; transition metals; tetraoctylphosphonium oleate.

Corresponding Author: Prof. Maaïke Christine Kroon, Ph.D.

Corresponding Author's Institution: Eindhoven University of Technology

First Author: Dries Parmentier, Ph.D.

Order of Authors: Dries Parmentier, Ph.D.; Sarah Paradis, MSc; Sybrand J Metz, Ph.D.; Susanne K Wiedmer, Ph.D.; Maaïke Christine Kroon, Ph.D.

Abstract: This work describes for the first time a continuous process for selective metal extraction with an ionic liquid (IL) at room temperature. The hydrophobic fatty acid based IL tetraoctylphosphonium oleate ([P8888][oleate]) was specifically chosen for its low viscosity and high selectivity towards transition metals. Applying [P8888][oleate] for continuous metal ion extraction with 0.1 M sodium oxalate for regeneration resulted in a process with good and stable extraction efficiencies over time. The selectivity of the IL resulted in a process in which cobalt was selectively removed from two mixed salt solutions (Co/Na, Ca/Co/K) to obtain a pure cobalt stream after stripping the IL. The performed experiments showed that the contact time of the IL for extraction and stripping strongly influenced the achieved efficiencies. The stability of the IL was tested and it was shown that the fatty acid based IL was stable for the duration of the experiment. Liposome tests showed that the IL is very hydrophobic, which limits its leakage towards the water phase, but also results in a higher toxicity towards cell membranes. Economic analysis shows that the IL based process is not (yet) economical compared to ion-exchange resins, in case demineralised water is the only product. However, if the recovery of valuable metals is also taken into account and/or if brine disposal is an issue, then continuous IL metal extraction systems must be regarded as promising alternatives.

Suggested Reviewers: Koen Binnemans PhD
Professor, Chemistry, KU Leuven
koen.binnemans@chem.kuleuven.be
specialist in salt extraction with ILs

Lethesh Kallidanthiyil Chellappan PhD
postdoctoral researcher, Chemical Engineering, Universiti Teknologi PETRONAS
letheshkc@gmail.com
expert in continuous processing using ILs

Joan Brennecke PhD

Professor, Chemical Engineering, University of Notre Dame
jfb@nd.edu
expert in separation processes using ILs

Irina Smirnova PhD
Professor, Chemical Engineering, University of Hamburg Harburg
irina.smirnova@tu-harburg.de
expert in hydrophobic ionic liquid/water systems including partition
coefficients of charged species (LLE data)

Alireza Shariati PhD
Associate professor, Chemical Engineering and Petroleum Engineering,
Shiraz University
shariati@shirazu.ac.ir
specialist in separation technology with ILs

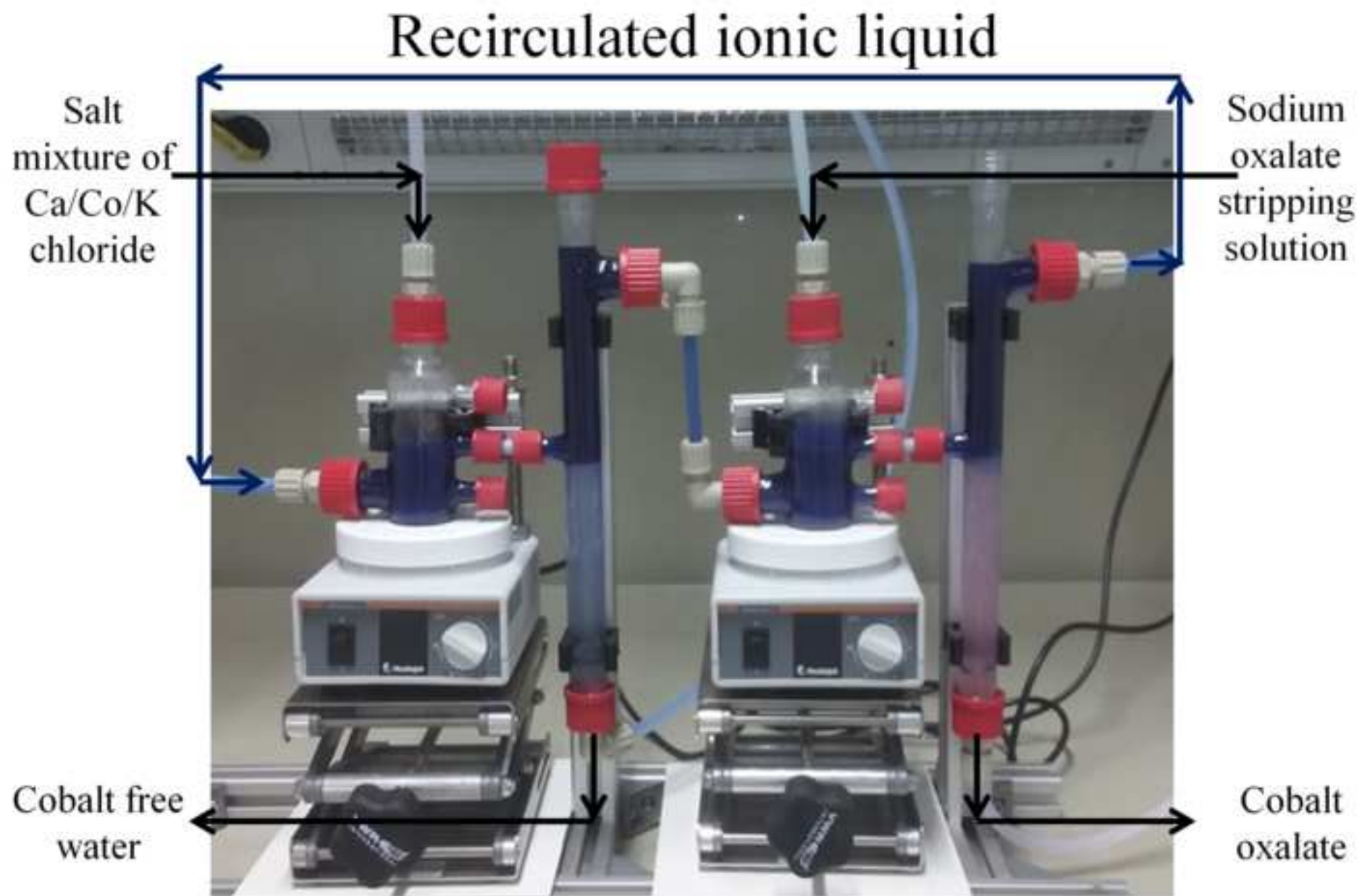

Continuous metal extraction setup

Highlights

- A continuous selective metal extraction process was developed using ionic liquids
- Continuous regeneration of the ionic liquid was included
- High cobalt extraction values were obtained from a mixed salt solution
- The ionic liquid was stable during 6 hours of operation
- The new process is a promising technique compared to ion-exchange

Continuous process for selective metal extraction with an ionic liquid

Dries Parmentier^{[a],[b]}, Sarah Paradis^[b], Sybrand J. Metz^[b], Susanne K. Wiedmer^[c] and Maaïke C. Kroon^{[a]*}

^[a]Separation Technology Group

Department of Chemical Engineering and Chemistry

Eindhoven University of Technology

Den Dolech 2, 5612 AZ Eindhoven, The Netherlands

^[b] Wetsus

European Centre of Excellence for Sustainable Water Technology

Oostergoweg 9, 8911 MA Leeuwarden, The Netherlands

^[c]Department of Chemistry, University of Helsinki

P.O. Box 55, 00014 University of Helsinki, Finland

* Corresponding author. E-mail: m.c.kroon@tue.nl; Phone: 31-40-2475289; Fax: +31-40-2463966.

Abstract

This work describes for the first time a continuous process for selective metal extraction with an ionic liquid (IL) at room temperature. The hydrophobic fatty acid based IL tetraoctylphosphonium oleate ($[P_{888}][oleate]$) was specifically chosen for its low viscosity and high selectivity towards transition metals. Applying $[P_{888}][oleate]$ for continuous metal ion extraction with 0.1 M sodium oxalate for regeneration resulted in a process with good and stable extraction efficiencies over time. The selectivity of the IL resulted in a process in which cobalt was selectively removed from two mixed salt solutions (Co/Na, Ca/Co/K) to obtain a pure cobalt stream after stripping the IL. The performed experiments showed that the contact time of the IL for extraction and stripping strongly influenced the achieved efficiencies. The stability of the IL was tested and it was shown that the fatty acid based IL was stable for the duration of the experiment. Liposome tests showed that the IL is very hydrophobic, which limits its leakage towards the water phase, but also results in a higher toxicity towards cell membranes. Economic analysis shows that the IL based process is not (yet) economical compared to ion-exchange resins, in case demineralised water is the only product. However, if the recovery of valuable metals is also taken into account and/or if brine disposal is an issue, then continuous IL metal extraction systems must be regarded as promising alternatives.

Keywords: ionic liquid, continuous metal extraction, selective metal extraction, transition metals, tetraoctylphosphonium oleate

Introduction

Since the late 1990, research about ionic liquids (ILs) came into the attention of a broader scientific community.^[1] These liquids are ionic salts which are liquids at room temperature, and are also referred to as “molten salts”.^[2] The ions in these ILs are large and are held together by electrostatic attractions, which result in different physical and chemical properties compared to conventional solvents. They are liquid over a wide range of temperatures, have a negligible vapour pressure, have a low flammability, but they also have a specific structure and coordination ability.^[3–5] Selecting specific anions and/or cations leads to ILs which are applicable for gas separation^[6–8] and purification,^[9,10] dissolution of cellulose^[11,12], selective extraction of organics from other media,^[13–16] dissolving metal oxides,^[17,18] and extraction of metals from the aqueous phase.^[19–25]

All of the above mentioned literature on the applications of ILs for metal extraction are performing its research in batch modes. However, to be industrially applicable, these processes should be performed in a continuous mode. In literature, there is to the authors’ knowledge at this moment only one article that describes a continuous metal extraction process based on ILs in a continuous mode.^[26] In this work, cobalt is selectively extracted from a cobalt/nickel stream by applying the ionic liquid, trihexyl(tetradecyl)phosphonium chloride, commercially known as Cyphos[®] IL 101. However, the disadvantage of this process is that the five mixer-settlers that were applied have to be heated to 50 °C in order to keep the viscosity of the IL sufficiently low to obtain fast extraction/stripping kinetics. This makes the process high energy demanding.

To overcome this limitation, a newly synthesized fatty acid based ionic liquid (IL), tetraoctylphosphonium oleate ([P₈₈₈][oleate]), was selected, which shows promising characteristics as an extractant for a sustainable process on selective metal recovery.^[27] This IL has the advantage of having a very low viscosity (10,8 wt% H₂O results in a viscosity of

183 mPa's at 20 °C) after water saturation.^[28] This results in a fast extraction/stripping kinetics which allows this process to be operated in a continuous mode at room temperature. Regeneration is also easily achievable by applying an aqueous 0.1 M sodium oxalate solution as stripping agent to recover the metals.^[29]

In this work, a system was developed and operated for the first time at room temperature in order to obtain continuous metal extraction based on the IL [P₈₈₈][oleate]. In this system, selective metal extraction of an aqueous waste stream was done in one compartment, while in a second compartment the IL loaded with the metal was stripped so that the IL could be recirculated to be reused for metal extraction. Also in this study, the long-term stability, degradation and harmfulness of the IL are evaluated, as well as the cost effectiveness of the continuous process.

Experimental

Materials

Tetraoctylphosphonium bromide (>95%) was supplied by Iolitec (Heilbronn, Germany). Oleic acid (90%) and sodium oxalate dihydrate (98%) were delivered by Alfa Aesar (Karlsruhe, Germany). Cobalt(II) chloride hexahydrate (99%) and monobasic hydrogen sodium phosphate ($\geq 99.0\%$) were delivered by Sigma-Aldrich (Zwijndrecht, Belgium). Sodium hydroxide ($\geq 97\%$), calcium chloride dihydrate ($\geq 99\%$) and potassium chloride ($\geq 99\%$) were delivered by VWR Chemicals (Leuven, Belgium). Chloroform (>99%) was purchased from Rathburn Chemicals Ltd. (Walkerburn, UK). 1-Palmitoyl-2-oleyl-*sn*-glycero-3-[phospho-*rac*-(1-glycerol)] (sodium salt) (POPG) was purchased from Genzyme Pharmaceuticals (Liestal, Switzerland) and L- α -phosphatidylcholine (Egg, Chicken) (EggPC) was from Avanti Lipids (Alabaster, AL, USA). MilliQ water (≥ 18.2 M Ω ·cm) used throughout

the synthesis and extraction/regeneration experiments utilized and was obtained by a Millipore MilliQ[®] biocel, which used a Q-grade[®] column.

Synthesis of the ionic liquid [P₈₈₈₈][oleate]

For this research the IL was synthesized on a larger scale than previously reported.^[28] First, oleic acid (57.98 mL, 0.231 mol) was mixed with an excess of NaOH (12.74 g, 0.319 mol) dissolved in 800 mL MilliQ water at 45 °C for 3 h in a 1 L flask. Afterwards, [P₈₈₈₈][Br] (100 g, 0.177 mol) was added to the reaction mixture and the mixture was stirred for an additional 6 h at 75 °C. The organic phase was then washed multiple times with water (6 x 500 mL) and remaining water was removed by a rotary evaporator (BUNCHI Rotavapor[®] R-3) and a vacuum oven at 50 °C to obtain a slightly yellow viscous liquid as product (135.1 g). The yield was 99%. The bromide content was 5 µg·mL⁻¹. The IL was determined by ¹H NMR (Bruker 400 MHz, CDCl₃, δ/ppm) and the following data was obtained: δ = 0.88 (m, 15H), 1.26 (m, 54H), 1.48 (m, 14H), 1.60 (m, 2H), 1.99 (m, 4H), 2.17 (t, 2H), 2.37 (m, 8H), 5.32 (m, 2H). MS (ESI) was run and the following data was obtained: [P₈₈₈₈(C₃₂H₆₈P)]⁺ *m/z* = 483.6 (calculated value *m/z* = 483.9) and [oleate (C₁₈H₃₃O₂)]⁻ *m/z* = 281.3 (calculated *m/z* = 281.5).

Experimental setup

Figure 1 presents a schematic drawing of the continuous setup, in which one can observe two mixer-settler extractors placed in series. The solutions are pumped into the extractors using 8 mm outer diameter pipes. *Masterflex L/S* pumps were set for the first experiment at 15 mL·min⁻¹ to get an accurately regulated flow of IL, aqueous metal solution and stripping solution in the set up. This flow rate made sure that the IL had a contact time of more than 4

min with the aqueous metal salt solution or aqueous stripping solution in the mixers, which is minimum time necessary to reach the equilibrium state for the extraction.^[28] For the second experiment the flow rate of the pumps was set at 20 mL min^{-1} . Two pumps were placed at the outlet of both settlers, which stabilized the height at which phase disengagement of the IL and water phase occurred. Mixing was done with magnetic mixing rods and the mixing plates (Heidolph MR Hei-Mix S) were set at 1200 rpm to allow rigorous mixing.

First, a continuous metal extraction experiment was performed with a solution consisting of 1.0 g L^{-1} Co and 1.0 g L^{-1} Na (Co/Na) from the corresponding chloride salts for 165 min. Afterwards, the experiment was repeated with a solution consisting out of 1.0 g L^{-1} cobalt, 1.0 g L^{-1} potassium and 1.0 g L^{-1} calcium (Co/K/Ca) from their chloride salts for 300 min. A 0.1 M aqueous sodium oxalate water solution was each time applied as stripping solution. IL was first water saturated before being applied in the continuous setup. The whole setup was first half filled with MilliQ water ($\pm 200 \text{ mL}$) and afterwards $\pm 200 \text{ mL}$ of water saturated IL was pumped into the setup. At the start of the experiments all pumps were turned on and all operated at the same speed.

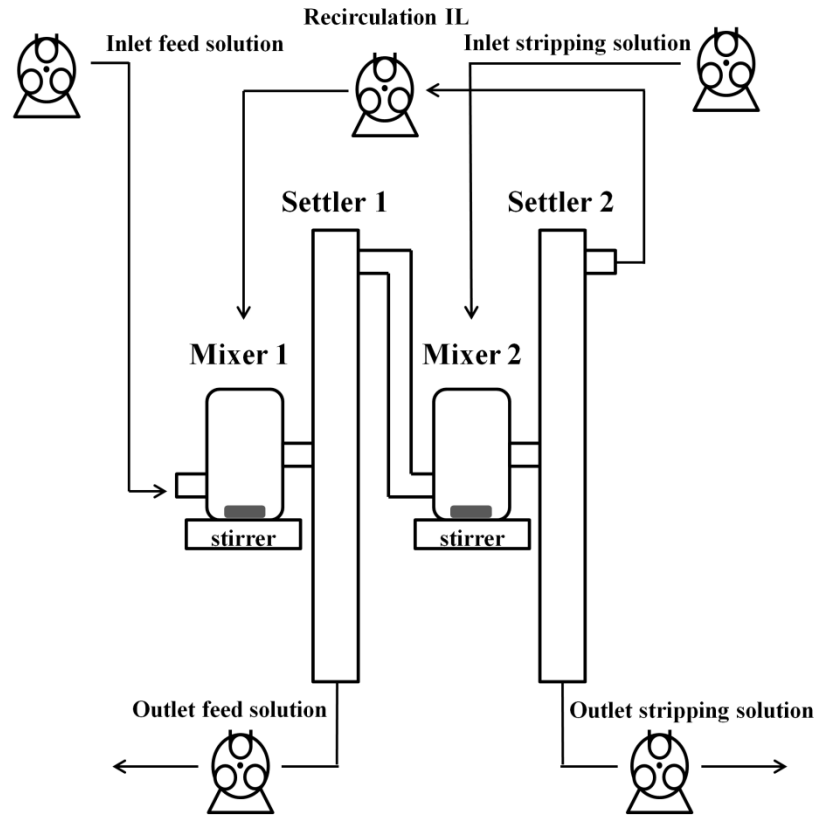

Figure 1. Schematic drawing of the continuous setup for metal extraction and IL regeneration.

Analysis of the aqueous metal solution and stripping solution

The aqueous metal solution and stripping solution were analysed before and after going through the continuous metal extraction setup. Every half hour, 30 mL of sample was taken at the outlets of the aqueous metal solution and the stripping solution after it passed through the continuous setup. The cation and anion concentration, pH, total organic carbon (TOC), inorganic carbon (IC) and total carbon (TC) were measured in these samples. For the cation analysis, a Perkin Elmer precisely inductively coupled plasma spectroscopy (ICP) was used, which used an optical atom emission spectrometer (OES) Optima 5300DV. Results were

obtained via a Winlab 32 ICP continuous automated analysis. The ICP-OES has a detection limit of 25-250 $\mu\text{g}\cdot\text{L}^{-1}$ and an uncertainty of 1.4-2%. Anion concentration analysis was done on a Metrohm 761 Compact ion chromatograph (IC) system equipped with a 762 IC interface which had a detection limit of 0.1 $\text{mg}\cdot\text{L}^{-1}$.

Extraction efficiencies (E) were calculated by:

$$E(\%) = ((c_{0\text{aq}} - c_{1\text{aq}}) * F_{\text{outlet feed}}) / (c_{0\text{aq}} * F_{\text{inlet feed}}) \times 100 \quad (1)$$

where $c_{0\text{aq}}$ and $c_{1\text{aq}}$ are the total metal concentrations in the aqueous phase before and after metal extraction in the first mixer settler occurred. $F_{\text{inlet feed}}$ equals the volume flow rate of the aqueous feed solution at the inlet of the first mixer and $F_{\text{outlet feed}}$ equals the volume flow rate of the aqueous feed solution at the outlet of first settler.

The stripping (S) efficiency was determined by equation 2:

$$S(\%) = (c_{2\text{aq}} * F_{\text{outlet stripping}}) / (c_{0\text{aq}} * F_{\text{inlet stripping}}) \times 100 \quad (2)$$

in which $c_{2\text{aq}}$ is the metal concentration in the aqueous phase after the stripping occurred in the second mixer settler and $c_{0\text{aq}}$ stands again for the concentration of ions in the start solution. $F_{\text{inlet stripping}}$ equals the volume flow rate of the cobalt loaded IL solution at the inlet of the second mixer and $F_{\text{outlet stripping solution}}$ equals the volume flow rate of the aqueous stripping solution at the outlet of the second settler.

The pH of the water phase was measured after the metal extraction experiment with a Metrohm 827 lab pH meter. The solubility of the IL in the water phases was measured by total organic carbon (TOC), inorganic carbon (IC) and total carbon (TC) analysis using a Shimadzu TOC-LCPH with a detection limit of 1.00 $\text{mg}\cdot\text{L}^{-1}$.

Critical micelle concentration determination of the IL

In order to get some information on the aggregation behaviour of the IL, the critical micelle concentration (CMC) of the IL in water was determined. The surface tension measurements were performed with a pendant drop method at room temperature using a CAM 200 Optical Contact Angle Meter (Biolin Scientific, KSV Instruments, Finland) equipped with a CCD Video Camera Module. Evaluation of data was performed using the Attension Theta Software (ver. 4.1.0, Biolin Scientific, Finland) with the frame interval of 1 s and 20 frames collection. Fitting of collected images was done using the Young-Laplace equation.

Liposome preparation

The liposomes were used as biomimetic models for predicting the toxicity of the studied compounds. Liposomes were prepared by mixing stock solutions of eggPC (20 mM) and POPG (15 mM) to yield a total concentration of 3.0 mM. The appropriate mixing ratio of lipid stocks in chloroform was 75/25 (mol%) of eggPC/POPG. The resulting mixture was evaporated to dryness under a stream of pressurized air, and solvent residues were removed by evacuation under reduced pressure (8–100 mbar) for at least 16 h. The lipid residues were hydrated in the sodium phosphate buffer at 60 °C for 60 min with shaking to yield multi-lamellar vesicles. The resulting dispersion was processed to give large uni-lamellar vesicles by extruding the mixture 19 times through Millipore (Bedford, MA, USA) 100-nm pore size polycarbonate filters using a Liposo-Fast extruder. The sizes were routinely confirmed by Malvern Zeta Sizer (data not shown).

Zeta potential determinations

Laser Doppler micro-electrophoresis, using a Malvern Zetasizer Nano ZS (Malvern Instruments, Malvern, UK) instrument, was used to measure the zeta potentials (surface charge) of the liposomes. Measurements were conducted in disposable folded capillary cells for zeta potential (surface charge) measurements. The liposome dispersion was diluted to a concentration equal to 0.1 mM. The IL was added to the liposome at various concentrations, in the range of 0-900 μM . The solvent for both liposomes and IL was a phosphate buffer at pH 7.4 (ionic strength of 10 mM). The samples were degassed using a vacuum degasser.

Long term stability experiment

Different [P₈₈₈][oleate] IL samples were left open to air at room temperature for a period of 3 months and periodically analyzed by electro-spray ionisation mass spectrometry (ESI-MS) to determine its stability. The samples were pure IL, IL with an excess of water and IL after the extraction of cobalt that was left in contact with the water phase originally containing 1.0 g·L⁻¹ of Co from its chloride salt. At defined intervals (start of the experiment, after 2 weeks, after 2 months, after 3 months) samples were taken. An Agilent Technologies 1200 series ESI-MS was applied with acetonitrile:water 90:10 v/v ratio as eluents working with an Agilent MassHunter workstation data acquisition. Also, ¹H NMR analysis was performed on a Bruker 400 MHz NMR on the IL before and after being applied in the continuous setup. Additionally, the kinematic viscosity of the IL after the second continuous metal extraction experiment was determined at 25 °C using a capillary viscometer 50120 of Schott Instruments.

Results and discussion

Continuous extraction study

[P₈₈₈][oleate] was selected as the extracting phase, both acting as a solvent and as the extractant for selective removal of transition metal ions from an aqueous metal salt solution.

Previous research demonstrated that this IL was very hydrophobic, so that losses into the water phase are minimized.²⁶ Moreover, it was shown that [P₈₈₈][oleate] can selectively extract metals depending on pH and chloride concentration and it has a low viscosity, even at room temperature.^[28,30] Therefore, this metal extraction process can be operated at room temperature with high enough extraction rates, which is a significant improvement and saving in energy cost compared to other IL metal extraction systems in which the water phase needs to be heated to elevated temperatures (≥ 40 °C).^[26] Based on previous results, sodium oxalate was selected as the optimal stripping solution.^[29] Although this stripping solution does not completely regenerate the IL phase, it allows reuse of the IL. In addition, sodium oxalate is safe to use, making this continuous extraction/regeneration setup easier to operate compared to other systems, which generally apply strong acids or bases for the regeneration.^[17,31–33] The setup applied for continuous metal extraction is shown in Figure 2. Cobalt was the preferred transition metal of choice for selective extraction, because of the nice visible colour it has in the aqueous phase (red/pink) and in the IL phase (dark blue).

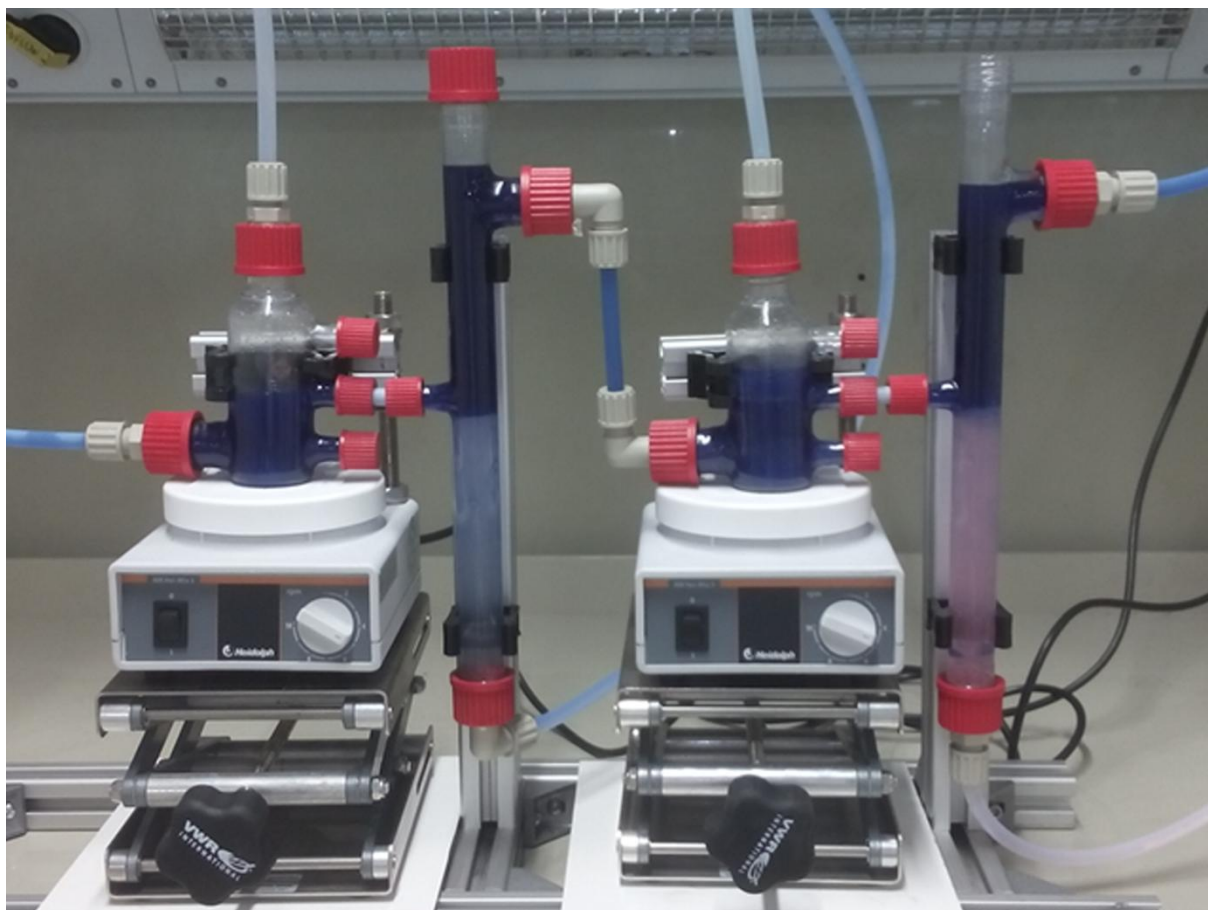

Figure 2. Continuous operated setup existing out of two mixer-settlers for selective removal of transition metals out of an aqueous salt stream by applying the ionic liquid tetraoctylphosphonium oleate.

In the first mixer, recirculated IL is mixed with the aqueous metal solution to perform selective metal extraction. At the start of each experiment a colour change of the IL from slight yellow towards dark blue was immediately observed due to the extraction of cobalt. Afterwards, the mixed aqueous IL solution underwent phase separation in the first settler. Clear transparent water from which the valuable cobalt salt is extracted is then obtained at the bottom of the first settler. IL loaded with cobalt is collected at the top and flows into the second mixer, in which it is mixed with the stripping solution. Phase disengagement then occurs in the second settler to obtain a pink water phase due to the back extraction of cobalt

by oxalate. The IL phase is then recirculated to the first mixer, so that it can be reused. The colour of the IL after stripping still remained blue, because the cobalt loaded IL was only partially removed from the IL.

Table 1. Chloride, sodium and cobalt concentration and pH of the feed solution and stripping solution.

	Cl (mg L ⁻¹)	Na (mg L ⁻¹)	Co (mg L ⁻¹)	pH
Feed solution	2775	918	921	6.2
Stripping solution	<20.0	>2000	<5	9.6

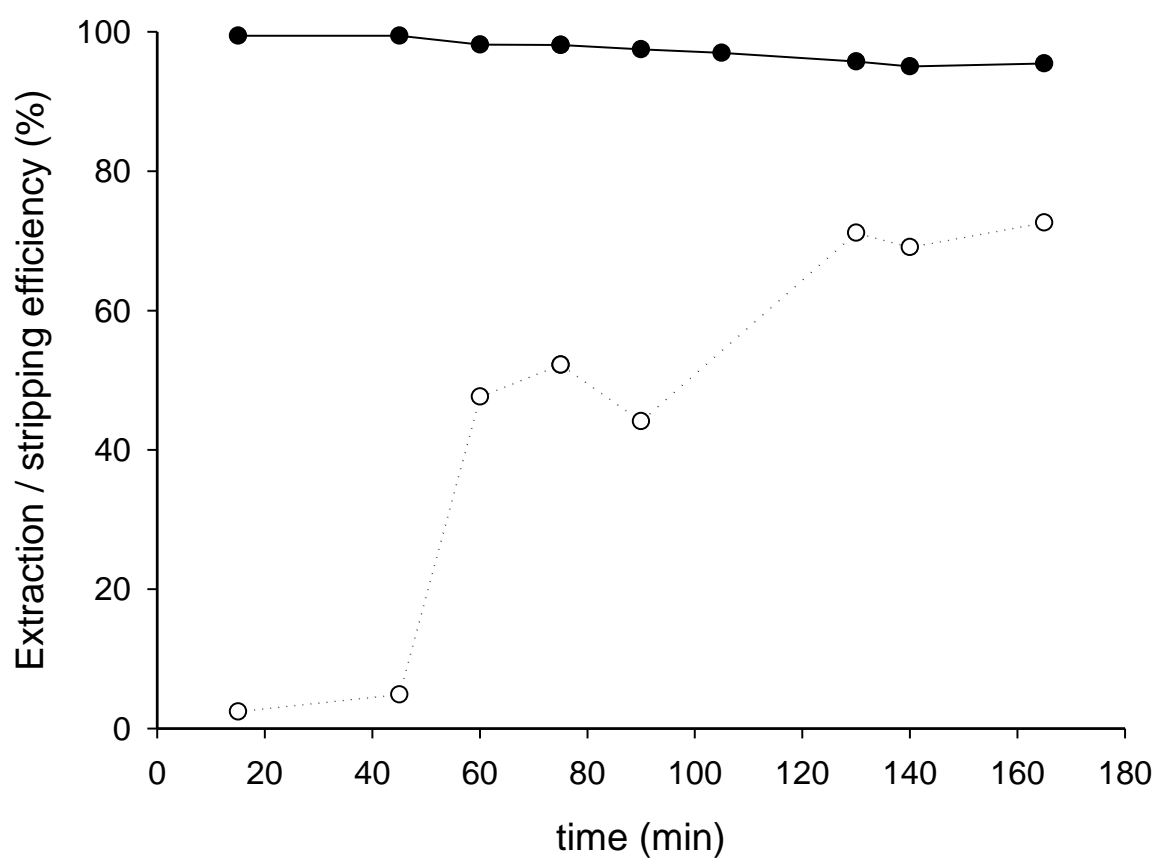

Figure 3. Extraction efficiency (●) and stripping efficiency (○) of the continuous metal extraction setup operated with a stream of 1.0 gL^{-1} Co/Na chloride at a flow rate of 15 mL min^{-1} for the whole process.

The first continuous metal extraction experiment was performed with a Co/Na feed solution presented in Table 1, which had a molar ratio of 0.39 for Co/Na. The flow rate of all solutions was 15 mL min^{-1} . Results of the extraction efficiency and stripping efficiency are presented in Figure 3. Figure 3 clearly shows that the extraction efficiency of cobalt remained high (>95%) during the 165 min of experimentation; there was only a small decrease in extraction efficiency over time. No extraction of sodium was observed. Results of the stripping solution indicate that the stripping solution was getting more concentrated in cobalt over time. A small decrease in pH was observed at the beginning of the experiment (Figure 4), but after about 60 min of operation the pH became stable. After 45 min of operation, the average pH value was 8.3 for the feed solution and 9.1 for the stripping solution.

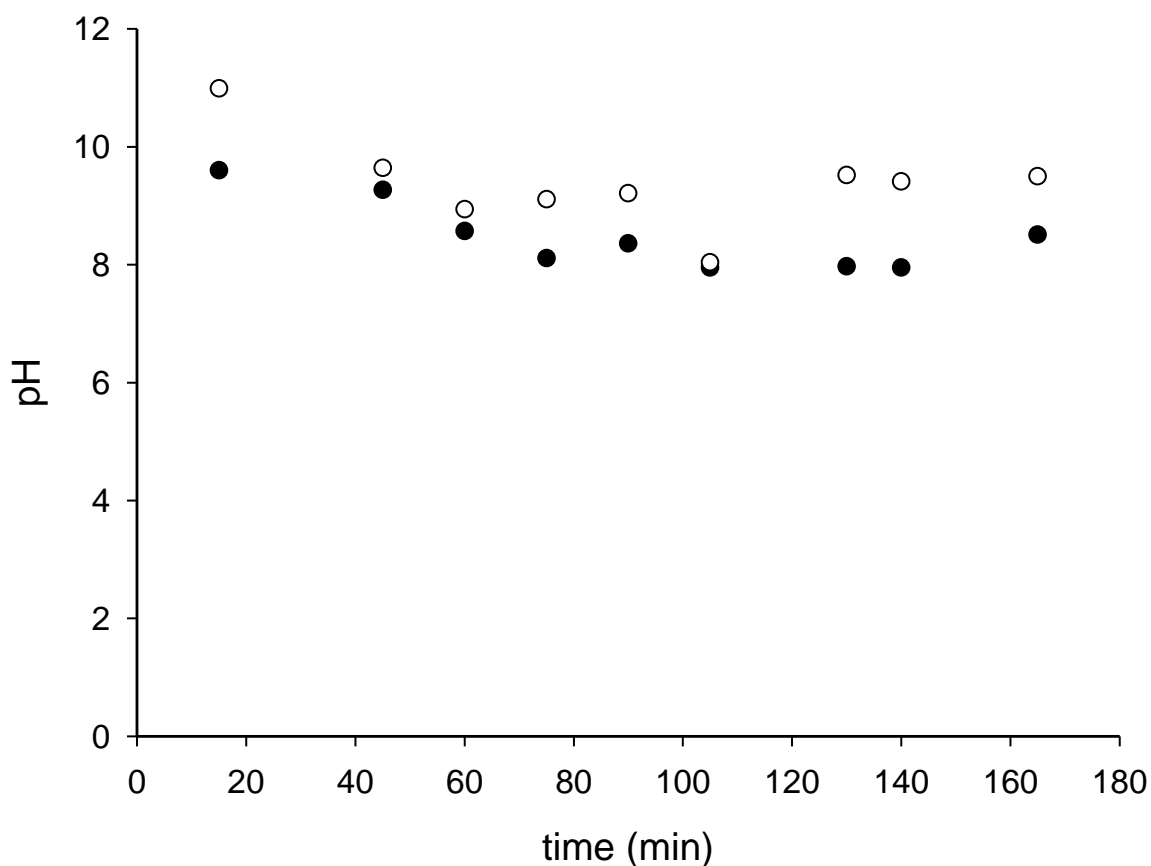

Figure 4. pH values for the feed solution (●) and stripping (○) solution for continuous metal extraction of the Co/Na stream over time.

Encouraged by the promising results obtained in the first experiment (see Figure 3), a second experiment was performed with a Ca/Co/K feed solution presented in Table 2 with a flow rate of $20 \text{ mL}\cdot\text{min}^{-1}$ for 5h. Molar ratio for the feed Ca/Co/K stream is 1.50:1.0:1.58. This feed solution was chosen to investigate the selectivity of the IL $[\text{P}_{888}][\text{oleate}]$ for transition metals over alkali and earth alkali metals over time. From the results in Figure 5, it is observed that the IL shows excellent extraction efficiencies ($t = 15 \text{ min}$, 96 %) at the beginning of the experiment, but decreases within 2h to an extraction efficiency that remains constant around 54%. At the beginning, also some extraction of calcium is observed ($t = 15 \text{ min}$, 21%), but this rapidly declines. On average, low and negligible extraction efficiencies are observed for

calcium (6%) and potassium (4%), proving the preference of the IL [P₈₈₈][oleate] for the transition metal cobalt. Sodium concentration in the feed solution after extraction was around 25 mg·L⁻¹, indicating that the extraction mechanism is not based on ion-exchange of sodium ions for cobalt ions. It is assumed that the lower extraction efficiency over time for cobalt compared to the first experiment is due to the higher flow rate of all streams (20 mL·min⁻¹ compared to 15 mL·min⁻¹), indicating that the contact time between the IL and the feed and stripping solution is a key factor. Nevertheless, it is worthy to note that the extraction efficiency for cobalt stays stable over time, indicating that the extraction and stripping in the setup reach a stable equilibrium and that there is no degradation of the IL occurring that prevents further metal extraction.

Results of the ion concentration from the consumed stripping solution are presented in Figure 6. The results in Figure 6 show that on average a 543 ±57 mg·L⁻¹ cobalt stream with an impurity of 56 ±19 mg·L⁻¹ calcium was obtained starting from a 987 ±18 mg·L⁻¹ calcium, 1013.5 ±23 mg L⁻¹ potassium and 969.5 ±16 mg·L⁻¹ cobalt feed stream. Results of potassium are not presented in Figure 6, because the concentration of potassium in the stripping solution was at or below the detection limit (10 mg·L⁻¹). Result of the obtained cobalt concentration in the stripping solution is in good agreement with the calculated amount of cobalt extracted (512 ±36 mg·L⁻¹; average concentration of cobalt extracted is determined from the average cobalt concentrations obtained between two and five hours of experiments, when the system reached its equilibrium state.) Results of the pH presented in Figure 7 indicate that the pH of both aqueous solutions remained constant after going through the continuous metal extraction setup. On average the feed solution after IL extraction had a stable pH of 7.8 and for the stripping solution a stable pH of 8.8 was observed. Also, the total organic carbon (TOC) content was measured in both solutions after contact with the IL (see supplementary information). The TOC content in the feed solution turned out to be ≤14 mg·L⁻¹, showing that

the leakage of IL going to the water phase is very small ($\leq 18 \text{ mg IL}\cdot\text{L}^{-1}$) and even some of the measured TOC in this solution can be originating from oxalate that was still in the IL. The stripping solution already contained $2440 \text{ mg}\cdot\text{L}^{-1}$ organic carbon at the start of the experiment due to the dissolved sodium oxalate. During the experiment the organic carbon content in the stripping solution fluctuated, but was on average $2414 \text{ mg}\cdot\text{L}^{-1}$, again indicating that only very small losses occurred.

Table 2. Chloride, calcium, potassium, sodium and cobalt concentration and pH of the feed solution and stripping solution at the start of the experiment.

	Cl (mg L^{-1})	Ca (mg L^{-1})	K (mg L^{-1})	Na (mg L^{-1})	Co (mg L^{-1})	pH
Feed solution	3675	987	1013.5	<50	969.5	5.97
Stripping solution	<20.0	<10	<10	>1000	<2.5	9.5

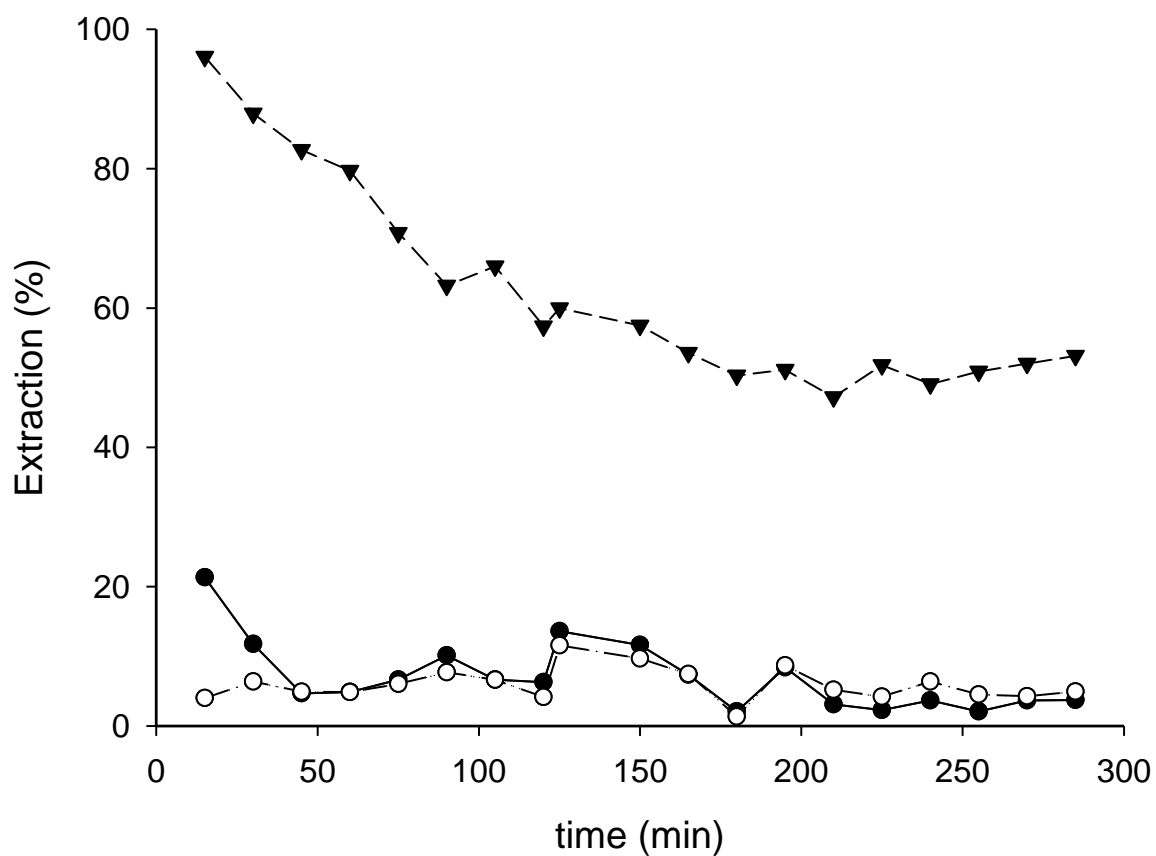

Figure 5. Extraction efficiencies as a function of time for the Ca(●)/Co(▼)/K(○) feed solution after metal extraction in the continuous setup at a flow rate of $20 \text{ mL}\cdot\text{min}^{-1}$ for the whole process.

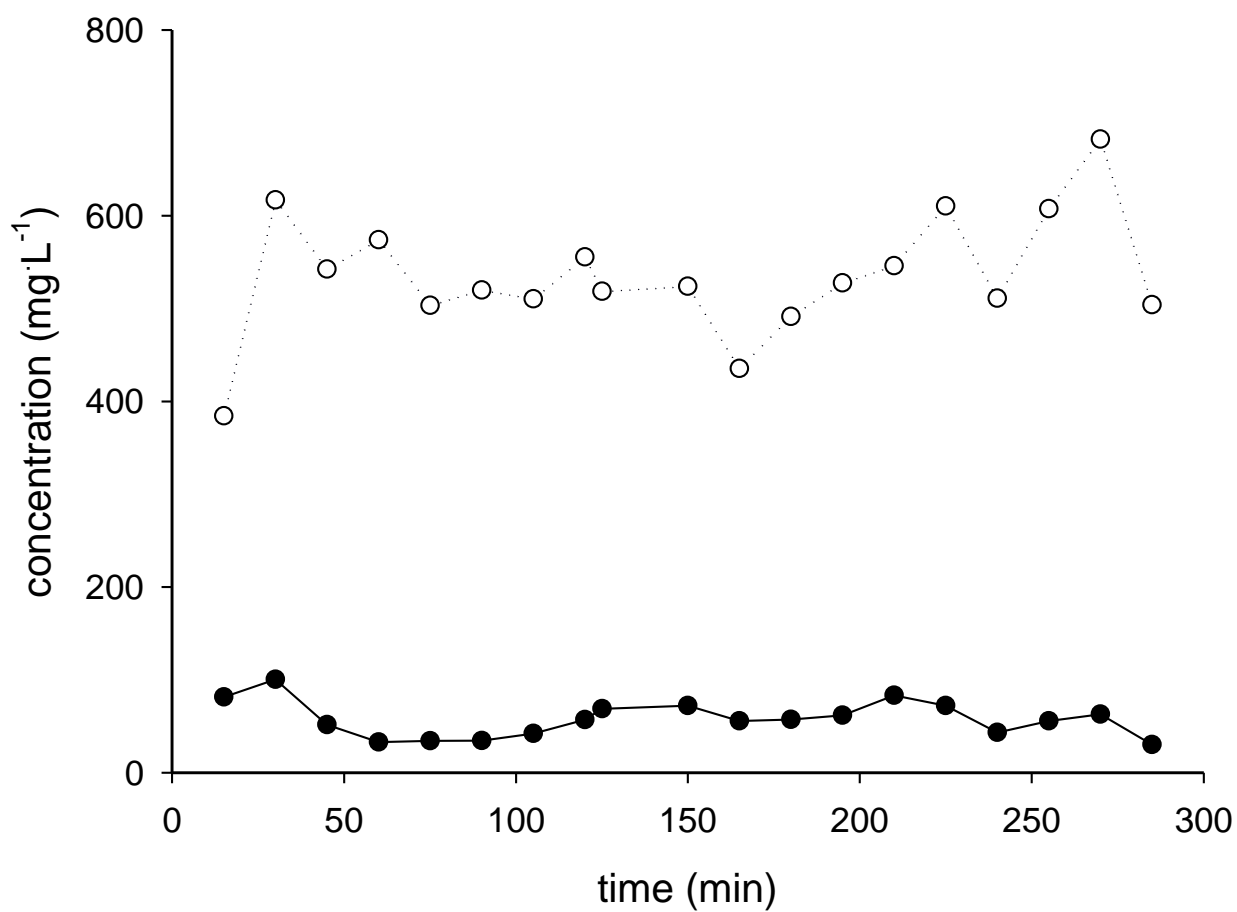

Figure 6. Change of metal ion concentration as a function of time in the stripping solution for Co(\circ) and Ca(\bullet) after being applied in the continuous setup.

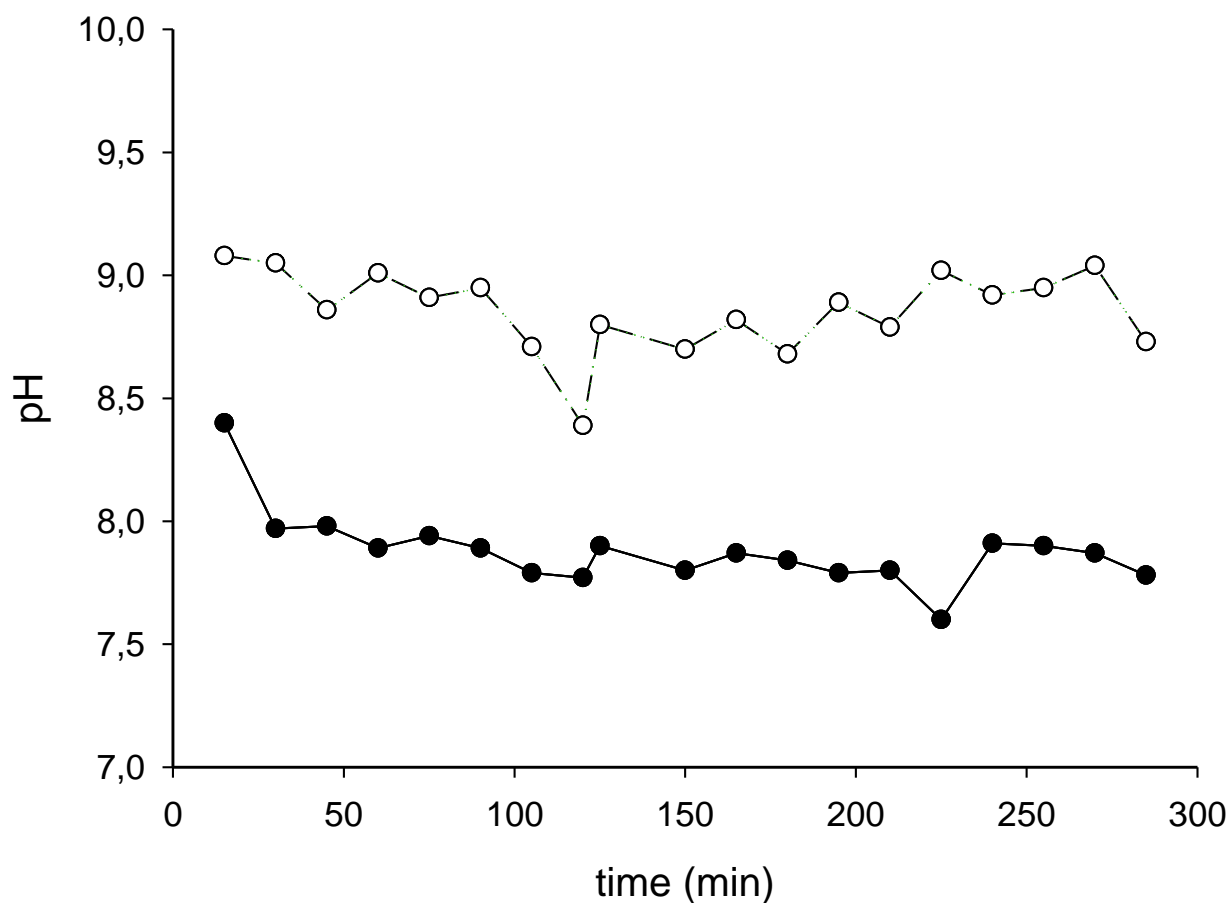

Figure 7. pH values for the feed solution(●) and stripping solution(○) after being applied in the continuous metal extraction setup as a function of time.

Interactions of the ionic liquid with liposomes

Interactions between ILs and cells as well as bio-mimetic liposomes have been studied to some extent.^[34–36] In those studies the focus has been on determining the toxicity of the ILs towards biological systems. It was shown that branched ions of the ILs can exert their toxic effect due to their ability to penetrate into the lipid bilayer, which furthermore causes membrane-bound protein disruption.^[37,38] Mikkola *et al.* recently demonstrated that human corneal epithelial cells and E coli bacterial cells were strongly affected by the type and concentration of the ILs studied.^[36] Shorter-chain amidinium and imidazolium ILs showed no

clear effect on the cells, whereas most of the longer-chain phosphonium ILs were highly toxic. Tested longer-chain phosphonium ILs were [P₁₄₄₄₄]Cl, [P₁₄₄₄₄][OAc] and [P₁₄₆₆₆][OAc] and these ILs had a CMCs of 0.3 mM, 0.3 mM and 0.1–0.2 mM in a 10 mM sodium phosphate buffer, respectively . The concentration of IL at which the surface charge of the liposomes changed was 0.230 and 0.218 mM for [P₁₄₄₄₄]Cl and [P₁₄₄₄₄][OAc], respectively.^[36] In this work the CMC of the IL was determined by the pendant drop method. The obtained value for the CMC was 6.72 μM. This very low value demonstrates the highly hydrophobic nature of the IL. Changes in the surface charge (zeta potential) of negatively charged liposomes upon addition of various concentrations of the IL (0-900 μM) were followed and the results are shown in Figure 8. There is a big change in the surface charge of the liposome, indicating strong electrostatic and hydrophobic interactions. The saturation level is around 250 μM of added IL. These data give us an idea about the effect of the IL on biological systems and clearly shows that the IL is highly hydrophobic and eager to interact with negatively charged liposomes, used as good bio-mimicking models. This indicates that the IL [P₈₈₈₈][oleate] also has a high toxicity towards cells because of its high lipophilicity, although it consists of a biodegradable anion and has a very low solubility in water.

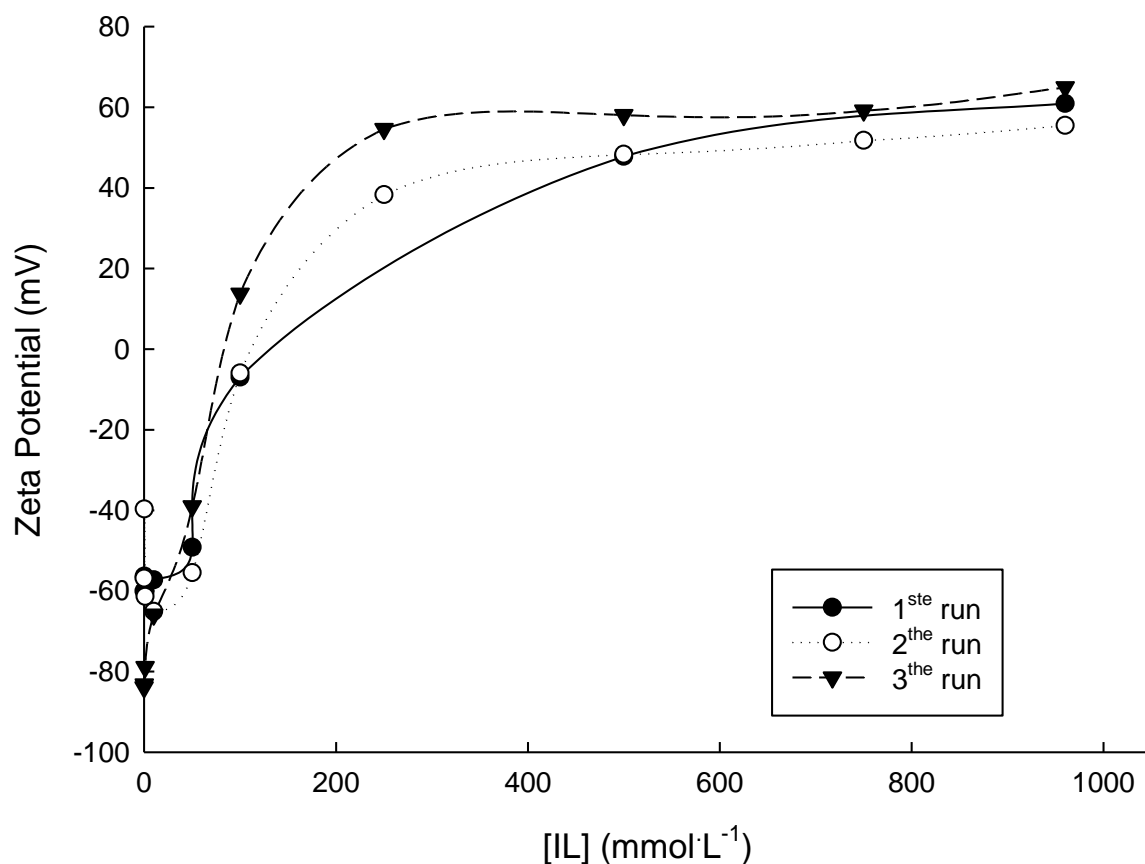

Figure 8. Zeta potentials of 75/25 mol% eggPC/POPG liposomes upon addition of $[P_{888}][oleate]$.

Stability of the ionic liquid

An often heard concern about applying fatty acid based ILs is their chemical stability. Therefore, an additional experiment was performed in which different $[P_{888}][oleate]$ IL samples were left open to air for a period of 3 months and periodically analyzed via ESI-MS (see supplementary information). The samples were pure IL, IL with an excess of water and IL after the extraction of cobalt that was left in contact with a water phase originally containing 1.0 gL^{-1} of Co from its chloride salt. For all these samples no changes in the MS spectra were observed for the whole duration of the experiment. Also, a ^1H NMR spectrum of

the IL that was applied for extraction of the Ca/Co/K feed solution was taken before and after usage (see supplementary information), indicating that except for the broadening of the peaks due to interaction of water and cobalt with the IL, no changes or additional peaks were observed in the NMR spectra. Moreover, the kinematic viscosity of the IL was determined after being applied in the continuous setup and turned out to be $162 \text{ mm}^2\cdot\text{s}^{-1}$. Comparing this value with the viscosity obtained for the full water saturated $[\text{P}_{888}][\text{oleate}]$ ($156 \text{ mm}^2\cdot\text{s}^{-1}$) shows no significant difference. The sample to determine the viscosity was taken from the second settler, indicating that the small increase in viscosity is most likely due to cobalt remaining in the IL. All these results indicate that there is no significant degradation occurring at the conditions applied (room temperature, pH 5.9-9.6) for continuous metal extraction.

Economic analysis of the continuous extraction process

The fatty acid based IL used in this research was designed to treat water, while minimizing the risk of polluting the water with toxic organic compounds. This has as risk, due to the oxidative reactivity of the anion of $[\text{P}_{888}][\text{oleate}]$, that this IL is not suitable for long-term operation at low (<4) or high (>8) pH and at high temperatures ($>50 \text{ }^\circ\text{C}$). Treatment of metal polluted water by this IL is only applicable for water with a pH ranging from 4-8. This makes the process less applicable for highly acidic water, which can contain high concentrations of dissolved transition metals. Instead, the developed process is more relevant for treatment of wastewater containing low transition metal ion concentrations. Biggest advantage of this process compared to other continuous metal extraction setups with ILs is that the complete process can be operated at room temperature, resulting in an enormous saving in energy cost.^[26]

Although the IL [P₈₈₈][oleate] can extract multiple transition metals and rare earth metals,^[28] a cobalt waste stream was chosen as subject for an economical analysis with this system due to the similarity with the lab experiment. Cobalt can be found in the waste streams of nuclear power plants and in many industries such as mining, metallurgical, electroplating, paints, pigments and electronic industry. In literature an example of a cobalt (Co) polluted waste stream from the paint industry can be found, which also contained the metals lead (Pb) and cadmium (Cd).^[39] In 2008, this industry with a 70 ton/month paint production had approximately 200 m³/month wastewater production. Table 3 presents the data of their waste water, which was used for the economic analysis in this study.

Table 3. Waste water characteristics of Binalood Paint Industries^[39]

Parameters	Mean	SD	Unit
pH	5.5	1.5	pH unit
BOD	252.5	20.9	mgL ⁻¹
COD	610.0	32.5	mgL ⁻¹
TSS	102.5	13.9	mgL ⁻¹
TDS	3325.0	491.1	mgL ⁻¹
EC	1750.0	217.3	μS·cm ⁻¹
Pb	5.4	1.3	mgL ⁻¹
Co	1.2	0.3	mgL ⁻¹
Cd	1.6	0.3	mgL ⁻¹

BOD = biological oxygen demand, COD = chemical oxygen demand, TSS = total suspended solids, TDS = total dissolved solids, EC = electrical conductivity

Heavy metals such as cobalt are nowadays often removed by applying ion-exchange resins (IER). Although IER sometimes show a very high selectivity towards specific metals, they cannot be operated in a continuous mode. Furthermore, recovery of the metals and reuse of

the resins is not always easily achieved. Still, a comparison of the continuous IL process in this work with a commercial IER that is selective for heavy metals (Purolite[®] S924) is made for the waste stream presented in Table 3. It is anticipated that both processes need the same pre-treatment steps to remove the organics from the total dissolved solids (TDS) in the water. The organics, that are partially soluble in water and contain charged functional groups, will most likely be extracted into the ILs phase (continuous IL process) or induce fouling (IER).

The economical analysis was performed for both systems (see supplementary information). It was shown that the capital expenditure (CAPEX) of the continuous IL based setup for the treatment of this specific waste water is expected to be 33% more expensive than two IER columns in parallel (€ 68370 for the IL system compared to €45100 for IER). The reason is that the IER for the removal of heavy metals cost 25 €/kg, which is somewhat lower than the assumed IL cost price at large scale production (33.7 €/L)(see supplementary information).^[1]

The operational cost for the IL process are also more expensive and this is mainly due to the consumption of high volumes of the stripping solution (the operational expenditures (OPEX) for the extraction and regeneration are 8.23 €/L for the IL system, while this is only 0.61 €/L for IER). Leakage of IL to the water phase should also be minimized over time through, for example, the implementation of filters/membranes at the outlet of the settlers, else the operation cost will further increase. Therefore, the IL process is not yet economically viable at the moment, especially if the only purpose of the process is to purify water by salt extraction. Nevertheless, continuous IL metal extraction systems can become a very good option if one also looks at the costs of brine disposal and the recovery and valorisation of valuable metals from waste water.

Conclusion

In this work, it is demonstrated for the first time that it is technically possible to operate a continuous process for selective metal extraction based on the IL [P₈₈₈][oleate] at room temperature. Good and stable extraction efficiencies were obtained in which excellent selectivity for cobalt was observed. For example, when working with a feed stream containing 1.0 gL⁻¹ of the metals Ca/Co/K, a concentrated cobalt stream was obtained containing 543 mgL⁻¹ of Co, 56 mgL⁻¹ of Ca and no detectable K. Noticeably, the extraction and stripping efficiencies were influenced by the contact time of the IL with the feed and aqueous solution. Furthermore, the fatty acid based IL was demonstrated to be stable for the duration of the experiment. Although this IL is very hydrophobic and consists of a natural fatty acid as anion, it strongly interacts with bio-mimicking liposomes due to its lipophilic character. Economic analysis shows that the IL based process that was developed was both more expensive in CAPEX and OPEX compared to ion-exchange resins, especially in case demineralised water is the only product. However, if the recovery of valuable metals is also taken into account and/or in case brine disposal is an issue, then continuous IL metal extraction systems are a promising alternative.

Acknowledgement

This work was performed in the cooperation framework of Wetsus, European Centre of Excellence for Sustainable Water Technology (www.wetusus.nl). Wetusus is co-funded by the Dutch Ministry of Economic Affairs and Ministry of Infrastructure and Environment, the European Union Regional Development Fund, the Province of Fryslân, and the Northern Netherlands Provinces. The authors like to thank the participants of the research theme “Salt” for the fruitful discussions and their financial support. Furthermore, the authors like to thank Joost Edens from DMT technologies and Anton Lapitski from PWG for their valuable input to define and discuss the economic evaluation. Financial support from the Magnus Ehrnrooth Foundation (Wiedmer) and the Academy of Finland (projects 266342 and 276075; Wiedmer) are gratefully acknowledged.

References

- [1] N. V Plechkova, K. R. Seddon, *Chem. Soc. Rev.* **2008**, *37*, 123–150.
- [2] R. D. Rogers, G. A. Voth, *Acc. Chem. Res.* **2007**, *40*, 1077–1078.
- [3] J. G. Huddleston, R. D. Rogers, *Chem. Commun.* **1998**, 1765–1766.
- [4] H. Zhao, S. Xia, P. Ma, *J. Chem. Technol. Biotechnol.* **2005**, *80*, 1089–1096.
- [5] J. S. Wilkes, *Green Chem.* **2002**, *4*, 73–80.
- [6] M. Althuluth, M. T. Mota-Martinez, A. Berrouk, M. C. Kroon, C. J. Peters, *J. Supercrit. Fluids* **2014**, *90*, 65–72.
- [7] G. E. Romanos, L. F. Zubeir, V. Likodimos, P. Falaras, M. C. Kroon, B. Iliev, G. Adamova, T. J. S. Schubert, *J. Phys. Chem. B* **2013**, *117*, 12234–51.
- [8] L. M. Galán Sánchez, G. W. Meindersma, A. B. de Haan, *Chem. Eng. Res. Des.* **2007**, *85*, 31–39.
- [9] M. Abai, M. P. Atkins, A. Hassan, J. D. Holbrey, Y. Kuah, P. Nockemann, A. A. Oliferenko, N. V Plechkova, S. Rafeen, A. A. Rahman, et al., *Dalton Trans.* **2015**, *44*, 8617–24.
- [10] G. Zarca, I. Ortiz, A. Urtiaga, *Chem. Eng. Res. Des.* **2014**, *92*, 764–768.
- [11] R. P. Swatloski, S. K. Spear, J. D. Holbrey, R. D. Rogers, *J. Am. Chem. Soc.* **2002**, *124*, 4974–4975.
- [12] H. Zhao, C. L. Jones, G. A. Baker, S. Xia, O. Olubajo, V. N. Person, *J. Biotechnol.* **2009**, *139*, 47–54.
- [13] L. A. Blanchard, D. Hancu, E. J. Beckman, J. F. Brennecke, *Nature* **1999**, *399*, 28–29.
- [14] S. Nasir Shah, M. I. A. Mutalib, R. B. M. Pilus, K. C. Lethesh, *Energy & Fuels* **2015**, *29*, 106–111.
- [15] O. Lebedeva, N. Root, D. Kultin, A. Moiseeva, L. Kustov, *Energy & Fuels* **2015**, *29*, 5253–5258.
- [16] M. Królikowska, M. Karpińska, *Fluid Phase Equilib.* **2015**, *400*, 1–7.
- [17] P. Nockemann, B. Thijs, S. Pittois, J. Thoen, C. Glorieux, K. Van Hecke, L. Van Meervelt, B. Kirchner, K. Binnemans, *J. Phys. Chem. B* **2006**, *110*, 20978–20992.
- [18] T. Vander Hoogerstraete, K. Binnemans, *Green Chem.* **2014**, *16*, 1594–1606.

- [19] V. V. Belova, a. a. Voshkin, a. I. Kholkin, a. K. Payrtman, *Hydrometallurgy* **2009**, *97*, 198–203.
- [20] L. Fischer, T. Falta, G. Koellensperger, A. Stojanovic, D. Kogelnig, M. Galanski, R. Krachler, B. K. Keppler, S. Hann, *Water Res.* **2011**, *45*, 4601–4614.
- [21] T. Vander Hoogerstraete, B. Onghena, K. Binnemans, *J. Phys. Chem. Lett.* **2013**, *4*, 1659–1663.
- [22] T. Vander Hoogerstraete, B. Blanpain, T. Van Gerven, K. Binnemans, *RSC Adv.* **2014**, *4*, 64099–64111.
- [23] A. Rout, J. Kotlarska, W. Dehaen, K. Binnemans, *Phys. Chem. Chem. Phys.* **2013**, *15*, 16533–16541.
- [24] T. Sato, M. Yamamoto, K. Adachi, *J. Min. Mater. Process. Inst. Japan* **2005**, *121*, 603–607.
- [25] D. Tsaoulidis, V. Dore, P. Angeli, N. V. Plechkova, K. R. Seddon, *Chem. Eng. Res. Des.* **2013**, *91*, 681–687.
- [26] S. Wellens, R. Goovaerts, C. Moeller, J. Luyten, B. Thijs, K. Binnemans, *Green Chem.* **2013**, *15*, 3160–3164.
- [27] D. Parmentier, S. J. Metz, M. C. Kroon, *Green Chem.* **2012**.
- [28] D. Parmentier, T. Vander Hoogerstraete, S. J. Metz, K. Binnemans, M. C. Kroon, *Ind. Eng. Chem. Res.* **2015**, *54*, 5149–5158.
- [29] D. Parmentier, Y. A. Valia, S. J. Metz, O. S. Burheim, M. C. Kroon, *Submitt. to Hydrometall.* **n.d.**
- [30] D. Parmentier, S. J. Metz, M. C. Kroon, *Green Chem.* **2013**, *15*, 205–209.
- [31] B. Onghena, J. Jacobs, L. Van Meervelt, K. Binnemans, *Dalt. Trans.* **2014**, *43*, 11566.
- [32] a. Cieszynska, M. Wisniewski, *Sep. Purif. Technol.* **2011**, *80*, 385–389.
- [33] M. Regel-Rosocka, *Sep. Purif. Technol.* **2009**, *66*, 19–24.
- [34] T. P. T. Pham, C.-W. Cho, Y.-S. Yun, *Water Res.* **2010**, *44*, 352–72.
- [35] A. Sosnowska, M. Barycki, M. Zaborowska, A. Rybinska, T. Puzyn, *Green Chem.* **2014**, *16*, 4749–4757.
- [36] S.-K. Mikkola, A. Robciuc, J. Lokajová, A. J. Holding, M. Lämmerhofer, I. Kilpeläinen, J. M. Holopainen, A. W. T. King, S. K. Wiedmer, *Environ. Sci. Technol.* **2015**, *49*, 1870–1878.
- [37] D. W. Roberts, *Sci. Total Environ.* **1991**, *109-110*, 557–568.

[38] D. Roberts, J. Costello, *QSAR Comb. Sci.* **2003**, 22, 220–225.

[39] M. Malakootian, H. Hossaini, *Int. J. Sci. Technol.* **2008**, 5, 217–222.