

<https://helda.helsinki.fi>

---

Spport burnout inventory dual career form for stu  
Assessing validity and reliability in a Finnish sample of  
adolescent athletes

Sorkkila, Matilda

2020-07

---

Sorkkila , M , Ryba , T V , Aunola , K , Selänne , H & Salmela-Aro , K 2020 , ' Sport burnout  
Spport inventory dual career form for student-athletes : Assessing validity an  
sample of adolescent athletes ' , Journal of Sport and Health Science , vol. 9 , no. 4 , pp.  
358-366 . <https://doi.org/10.1016/j.jshs.2017.10.006>

---

<http://hdl.handle.net/10138/319085>

<https://doi.org/10.1016/j.jshs.2017.10.006>

---

cc\_by\_nc\_nd

publishedVersion

---

*Downloaded from Helda, University of Helsinki institutional repository.*

*This is an electronic reprint of the original article.*

*This reprint may differ from the original in pagination and typographic detail.*

*Please cite the original version.*

Original article

# Sport burnout inventory—Dual career form for student-athletes: Assessing validity and reliability in a Finnish sample of adolescent athletes

Matilda Sorkkila<sup>a,\*</sup>, Tatiana V. Ryba<sup>a</sup>, Kaisa Aunola<sup>a</sup>, Harri Selänne<sup>b</sup>, Katariina Salmela-Aro<sup>a,c</sup>

<sup>a</sup> Department of Psychology, University of Jyväskylä, Jyväskylä 40014, Finland

<sup>b</sup> Mehiläinen Sports Medical Clinic, Jyväskylä 40100, Finland

<sup>c</sup> Cicero Learning, University of Helsinki, Helsinki 00014, Finland

Received 16 March 2017; revised 1 June 2017; accepted 11 July 2017

Available online 18 October 2017

2095-2546/© 2020 Published by Elsevier B.V. on behalf of Shanghai University of Sport. This is an open access article under the CC BY-NC-ND license. (<http://creativecommons.org/licenses/by-nc-nd/4.0/>)

## Abstract

**Background:** The pressure of pursuing an athletic career simultaneously with education may set adolescent student-athletes at risk for sport and school burnout. Although the 2 life domains of student-athletes are strongly intertwined, so far, there has not been an instrument for investigating sport burnout parallel to school burnout. The aim of the present study was to introduce a sport burnout measure for adolescents in a dual career context and investigate its validity and reliability by using confirmatory factor analysis.

**Methods:** The participants were 391 student-athletes (51% females) who filled in a questionnaire of sport burnout and background variables in the beginning of upper secondary school.

**Results:** A 3-factor model or a second-order-factor model described the data better and gave better reliability indices than a 1-factor model. The 3 dimensions of sport burnout were shown to be separate, but closely related constructs. Evidence for convergent and discriminant validity was obtained by correlating the 3 sport burnout dimensions with depressive symptoms, self-esteem, and sport task values.

**Conclusion:** The results suggest that Sport Burnout Inventory—Dual Career Form (SpBI-DC) is a valid and reliable instrument for investigating sport burnout among adolescent student-athletes.

**Keywords:** Confirmatory factor analysis; Depressive symptoms; Dual career; Self-esteem; Sport burnout inventory; Sport task values

## 1. Introduction

Massive numbers of adolescents participate in organized sport during their education years worldwide. For example, in the USA, more than 400,000 students participate in intercollegiate athletic programs yearly,<sup>1</sup> whereas in Canada 84% of young adolescents have reported participating in sports.<sup>2</sup> According to Wylleman and Lavallee's lifespan perspective on athletes' development,<sup>3</sup> transition into elite sport often coincides with educational and professional development of athletes, which makes it stressful for them to reconcile training and competition demands with the requirements and restrictions in educational systems. The challenge of combining elite sport and education has been acknowledged in the international sport psychology literature<sup>4</sup> and it has also received government attention. For

example, the European Commission outlined its suggestions for the promotion of elite sport development in a socially responsible manner.<sup>5</sup> The pressure of striving in 2 intertwined domains may set student-athletes at risk for sport and school burnout. Indeed, in a recent study conducted in Finland, student-athletes on a dual career path were found to report both sport or school burnout symptoms as soon as the beginning of upper secondary school.<sup>6</sup> In addition to cumulative mental health problems, burnout is associated with sport and school dropouts.<sup>7,8</sup>

Despite the severity of this issue, so far there has not been a scale to measure sport burnout in a dual career context. Although several tools have been developed to investigate sport burnout (e.g., Athlete Burnout Questionnaire (ABQ);<sup>9</sup> Eades Athlete Burnout Inventory (EABI);<sup>10</sup> The Sport Adaptation of Maslach Burnout Inventory (SAMBI)<sup>11</sup>) these instruments do not allow for parallel investigation of sport and school burnout in student-athletes. Among student-athletes the 2 life domains (i.e., sport and school) are strongly intertwined,

Peer review under responsibility of Shanghai University of Sport.

\*Corresponding author.

E-mail address: [matilda.2.sorkkila@jyu.fi](mailto:matilda.2.sorkkila@jyu.fi) (M. Sorkkila).

one domain constantly affecting the other, and, consequently, there is a need to address burnout symptoms in these 2 domains simultaneously. From a methodological point of view, using scales including parallel items for the sport and school domains would make it possible to get comparable results of burnout symptoms on these 2 different life domains. The present study introduces a novel instrument called Sport Burnout Inventory—Dual Career Form (SpBI-DC), which is designed particularly for youth athletes on a dual career track. The study, furthermore, investigates the validity and reliability of the SpBI-DC in a Finnish sample of student-athletes.

### 1.1. Sport burnout within dual career context

A number of different tools have been employed to measure athlete burnout, with varying success.<sup>12–14</sup> Initially, well-established instruments from work context were adapted into sport context,<sup>11</sup> the most widely used being the Maslach Burnout Inventory (MBI).<sup>15</sup> The original MBI is comprised of 3 dimensions: emotional exhaustion (i.e., feelings of extreme fatigue), depersonalization (i.e., negative or indifferent attitude toward clients), and reduced personal accomplishment (i.e., negative evaluations of oneself). The adaptation of the scale to a sport context (see SAMBI<sup>11</sup>) has been problematic because of the “depersonalization” dimension, as the provider—recipient relationship (i.e., one being worker and one client) does not define the central aspects of sports. Furthermore, no published studies have investigated the psychometric properties of the SAMBI,<sup>12</sup> which makes it questionable to use the scale.<sup>14</sup>

Other attempts to measure sport burnout include, for example, the EABI<sup>10</sup> that was invented as part of an unpublished Master's thesis. Although the scale has been used in published studies, it has been criticized for not being theoretically grounded and difficult to interpret.<sup>12</sup> The most promising and used measure of athlete burnout thus far has been ABQ,<sup>9,16</sup> which is developed based on the MBI. The measure conceptualizes sport burnout as consisting of emotional or physical exhaustion, reduced sense of accomplishment, and sport devaluation. The ABQ has gained empirical support and is considered a theory-based instrument for measuring athlete burnout in a sport context. Although the ABQ has been widely used, it has been also criticized for not showing sufficient psychometric evidence.<sup>17</sup> For example, in the comparison of MBI and ABQ,<sup>18</sup> factor loadings on general factors (i.e., exhaustion, cynicisms, and inadequacy) were not reported, but claims of construct validity were based on correlations between the subscales.<sup>17</sup> Consequently, it has been noted, that there may not be an optimal measure yet for sport burnout, although researchers typically adopt the ABQ.<sup>17</sup> It has been pointed out that having 1 dominant instrument in the field may be dangerous, because the questionnaire and definition of burnout may become “2 sides of the same coin” (p. 193): the instrument measures what burnout is, and burnout is what the instrument measures.<sup>19</sup> Another challenge of ABQ is that no comparable scales for other life domains are evident and, thus, comparisons of the levels of burnout symptoms in different contexts are not possible when using this particular scale. In the case of student-athletes, the contexts of sport and school constantly

interact, and therefore, sport and school burnout should be concurrently investigated. To make this possible, scale with parallel items in school and sport domains are needed.

In order to gain equal measurements for sport and school burnout we developed a new scale labelled SpBI-DC based on the widely used and validated scale of school burnout, that is, School Burnout Inventory (SBI).<sup>20,21</sup> School burnout has been defined as a multidimensional construct consisting of school-related exhaustion (i.e., chronic fatigue due to over-taxing in school), school-related cynicism (i.e., loss of interest in school-work accompanied with indifferent or distal attitude toward school), and feelings of inadequacy as a student (i.e., less successful achievement and reduced feelings of competence in school).<sup>20,21</sup> Similarly to school burnout, in the SpBI-DC sport burnout was defined as a multidimensional construct consisting of sport-related exhaustion (i.e., chronic fatigue due to over-taxing in sport), cynicism (i.e., loss of interest in sport accompanied with indifferent or distal attitude toward one's sport), and feelings of inadequacy as an athlete (i.e., less successful achievement and reduced feelings of competence in sport).

In our previous study, sport and school burnout were found to be related but separate constructs.<sup>6</sup> Although there are conceptual similarities between the 2 constructs (e.g., both sport and school burnout are stress-related conditions), they refer to context specific sources of stress (i.e., in school context the source of stress is school, whereas in sport context the source of stress is sport). A significant advantage of the SpBI-DC scale is that even though it shares the theoretical grounding of the ABQ,<sup>9</sup> the items of the scale match directly the items of the SBI,<sup>20,21</sup> and therefore, statistical procedures, such as multilevel modeling across contexts can be performed. Because the scale is also shorter than the ABQ,<sup>9</sup> it may be more convenient to administer to adolescents and easier to include into batteries of tests. The scale consists of 10 items measuring 3 dimensions of sport burnout, namely exhaustion, cynicism, and inadequacy.

### 1.2. Predictors of sport burnout

In the previous literature, many individual characteristics have been investigated as antecedents of sport burnout, such as high perceptions of stress and anxiety and avoidance-related goals.<sup>22</sup> Moreover, the role of motivational factors in development of sport burnout has been emphasized.<sup>23</sup> Subjective task values, which consist of interest, importance, and utility values one attaches to different activities, are important determinants of achievement-related choices and motivation.<sup>24</sup> Interest values refer to pleasure and enjoyment associated with the activity; importance values refer to the importance of operating in line with one's core-values and satisfying personal needs; and utility values refer to whether activity is perceived as useful in terms of achieving other goals. It has been shown that lack of motivation is associated with high levels of sport burnout symptoms, and high intrinsic motivation is negatively associated with sport burnout symptoms.<sup>9,12</sup> In addition to motivation, self-esteem has been negatively associated with sport burnout symptoms.<sup>25</sup> Self-esteem can be defined as “the overall evaluation of one's worth or value as a person”.<sup>26</sup> In a sport context, it has been shown that

performing well may become a vehicle for athletes to enhance and maintain self-esteem.<sup>25</sup> Deteriorated results and symptoms of sport burnout, namely exhaustion, inadequacy, and cynicism, may therefore decrease athletes' overall self-esteem.<sup>27</sup> Consequently, it was assumed that sport task values and self-esteem would be negatively related to sport burnout.

Another important factor which has been related to sport burnout is symptoms of depression.<sup>12</sup> Although the 2 concepts are associated, they still differ in important ways both empirically and theoretically.<sup>12</sup> Most importantly, at least the initial symptoms of burnout seem to be context specific<sup>28</sup> whereas symptoms of depression are pervasive and influence nearly all activities.<sup>29</sup> Studies have consistently shown that depressive symptoms are associated particularly with the exhaustion dimension of burnout,<sup>30,31</sup> and therefore, it has been argued that valid and reliable sport burnout measures must demonstrate convergence with depressive symptoms.<sup>12</sup> It has been shown that obtaining information of depressive symptoms from adolescents' mothers may be particularly useful in predicting future depression.<sup>32</sup> Consequently, we used mother-rated depressive symptoms as a predictor of sport burnout, and we expected depressive symptoms to be associated positively with symptoms of sport burnout.

### 1.3. Sport burnout and background variables

Various background variables, such as type of sport (i.e., individual vs. team) and gender, have previously been associated with sport burnout. For example, in elite athletes, sport burnout has been shown to be more common in individual sports than team sports.<sup>33</sup> It has been suggested that factors related to social support, such as cooperation and encouragement, may be emphasized more in team sports than in individual sports, explaining the difference in burnout levels between the 2 types of sport.<sup>33</sup> Moreover, females have been shown to be more at risk for sport burnout than males.<sup>6,33</sup> This may be explained by traditional gender beliefs and fewer opportunities available for female athletes to pursue professional athletic careers compared to men.<sup>34</sup> Due to these findings, background variables of type of sport and gender were controlled for in the present study.

### 1.4. The present study

The present study is part of the ongoing Adolescent Dual Careers study in Finland.<sup>35</sup> The overall purpose of the present study was to introduce a novel instrument for investigating sport burnout in dual career settings and to examine the reliability and validity of SpBI-DC in a sample of male and female upper secondary sport school students. The first aim was to investigate the construct validity of SpBI-DC. We tested the structure of SpBI-DC by comparing the goodness-of-fit of the 3-factors model of sport burnout to the 1-factor model. We expected that a 3-factor model consisting of exhaustion in sport, cynicisms toward sport, and perceptions of inadequacy as an athlete would describe the phenomenon of sport burnout better than a 1-factor model consisting overall sport burnout.<sup>21</sup> Second, we examined item reliability and

scale reliability of SpBI-DC. Finally, we examined discriminant and convergent validity of SpBI-DC by investigating how the scale would correlate with self-rated sport-related task-values and self-esteem (discriminant validity), and parent-rated depressive symptoms (convergent validity), while controlling for gender and type of sport (individual vs. team). It was expected that higher sport-related task-values and self-esteem would be associated with lower sport burnout symptoms, and that higher depressive symptoms would be associated with higher sport burnout symptoms.

## 2. Methods

### 2.1. Participants

The participants were 391 female (51%) and male student-athletes from 6 different upper secondary sport schools in Finland and 260 mothers. The mean age of the athletes was  $16 \pm 0$  years. Fifty percent of the athletes practiced individual sports (e.g., judo, track and field) and 50% team sports (e.g., football, ice hockey). The athletes practiced sport or engaged in activities related to their sport (e.g., traveling to training) on average for  $25 \pm 9$  h/week. Athletes competed at various levels (i.e., regional, national, international), and had been competing, on average, for  $7 \pm 2$  years.

### 2.2. Procedure

The study was approved by the Ethics Committee of the University of Jyväskylä. The data were collected at the beginning of the first year of upper secondary school during class time in the autumn of 2015. After the athletes were informed of the study objectives, they filled in an informed consent and a battery of questionnaires, which included SpBI-DC. All data were collected in Finnish. At the same time a set of questionnaires, which included a questionnaire of the child's depressive symptoms was sent to both parents. Because the fathers' response rate (<50%) was low, in the present study only mothers' (response rate 66%) answers were used.

### 2.3. Measurements

#### 2.3.1. Sport burnout

Sport burnout was measured with SpBI-DC, which is a modified SBI.<sup>20,21</sup> The scale consisted of 10 items measuring 3 dimensions of sport burnout: (a) exhaustion from one's sport (4 items; e.g., I feel overwhelmed by my sport); (b) cynicism toward the meaning of one's sport (3 items; e.g., Sport doesn't interest me anymore); and (c) feelings of inadequacy as an athlete (3 items; e.g., I often have feelings that I'm not doing well in my sport). All items were rated on a 5-point Likert-scale (1 = *strongly disagree*; 5 = *strongly agree*). The Cronbach  $\alpha$  reliabilities for the 3 subscales were 0.74, 0.80, and 0.78, respectively. The Cronbach  $\alpha$  reliability for the total scale was 0.85.

#### 2.3.2. Sport task values

Sport task values were measured with a modified scale based on Eccles et al.<sup>24</sup> This scale consists of 13 items measuring 3 dimensions: (a) interest values (5 items; e.g., How much do you

like playing your sport?) in which the items are rated on a 5-point Likert scale ranging from 1 (*not at all*) to 5 (*very much*); (b) importance values (4 items; e.g., How important is it to you that you do well in your sport?) rated on a 5-point Likert scale from 1 (*not at all important*) to 5 (*very important*); and (c) utility values (4 items; e.g., How useful is practicing your sport for what you want to do after you graduate or go to work?) in which the items are rated on a 5-point Likert scale ranging from 1 (*not very useful*) to 5 (*very useful*). The Cronbach  $\alpha$  reliabilities for the 3 subscales were 0.78, 0.81, and 0.80, respectively.

2.3.3. Depressive symptoms

Athletes' depressive symptoms were measured with items drawn from the internalizing symptom subscale of Strengths and Difficulties Questionnaire (SDQ),<sup>36</sup> in which student-athletes' mothers were asked to rate to what extent the statements correspond to their child. The scale consisted of 7 items (e.g., He/she is often sad) rated on a 5-point Likert-scale (1 = *strongly disagree*; 5 = *strongly agree*). The Cronbach  $\alpha$  reliability for the scale was 0.71.

2.3.4. Self-esteem

Athletes' self-esteem was measured with 5 items (e.g., On the whole, I feel satisfied with myself) taken from Rosenberg's Self-Esteem scale.<sup>37</sup> The items were rated on a 5-point Likert scale (1 = *strongly disagree*; 5 = *strongly agree*). The Cronbach  $\alpha$  reliability for the scale was 0.77.

2.4. Analysis strategy

The SpBI-DC items were investigated with confirmatory factor analysis by using the *Mplus* package (7th edition).<sup>38</sup> A missing-data method was used, in which all available data were used to estimate the model without inputting data. The maximum-likelihood-robust estimation method was applied

for estimating the parameters of the model. The goodness-of-fit was evaluated by using 4 indicators: (1)  $\chi^2$  test, (2) Bentler's (1990) comparative fit index (CFI), (3) the Tucker-Lewis Index (TLI), and (4) root mean square error of approximation (RMSEA). Based on the criteria of Hu and Bentler,<sup>39</sup> values above 0.95 for CFI and TLI and a value below 0.08 for RMSEA were considered indicating a good fit between the observed data and hypothesized model.

The analyses were performed in 4 steps. First, the structure of SpBI was determined by comparing 2 alternative theoretical models: (1) a 1-factor model (M1) in which 1 latent factor was expected to underlie all SpBI items, and (2) a 3-factor model (M2) in which 3 correlated latent factors (exhaustion, cynicism, and inadequacy) were expected to underlie the SpBI items. The 2 theoretical models were estimated independently, and Satorra-Bentler scaled  $\chi^2$  test for difference<sup>35</sup> was used to compare the goodness of fit of the models. Second, it was investigated whether second-order-factor model (M3) could describe the phenomenon of sport burnout. In this model the relationships between the 3 first-order factors (exhaustion, cynicism, and inadequacy) were assumed to be explained by a second-order factor consisting of overall sport burnout. In order to show sufficient reliability and validity, the second-order latent factor of overall sport burnout needs to have a relatively high correlation between the first-order factors.<sup>21</sup> It needs to be noted that the M2 and M3 models have the same number of estimated parameters and are therefore data-equivalent. The 3 theoretical models are shown in Fig. 1.

The third step was to investigate the validity and reliability of the items of SpBI-DC by using confirmatory factor analysis (CFA). First, item reliability was measured by examining squared correlations between the item and the factor. Next, standardized factor loadings were used to measure structural validity of the items. Finally, internal consistency of SpBI-DC

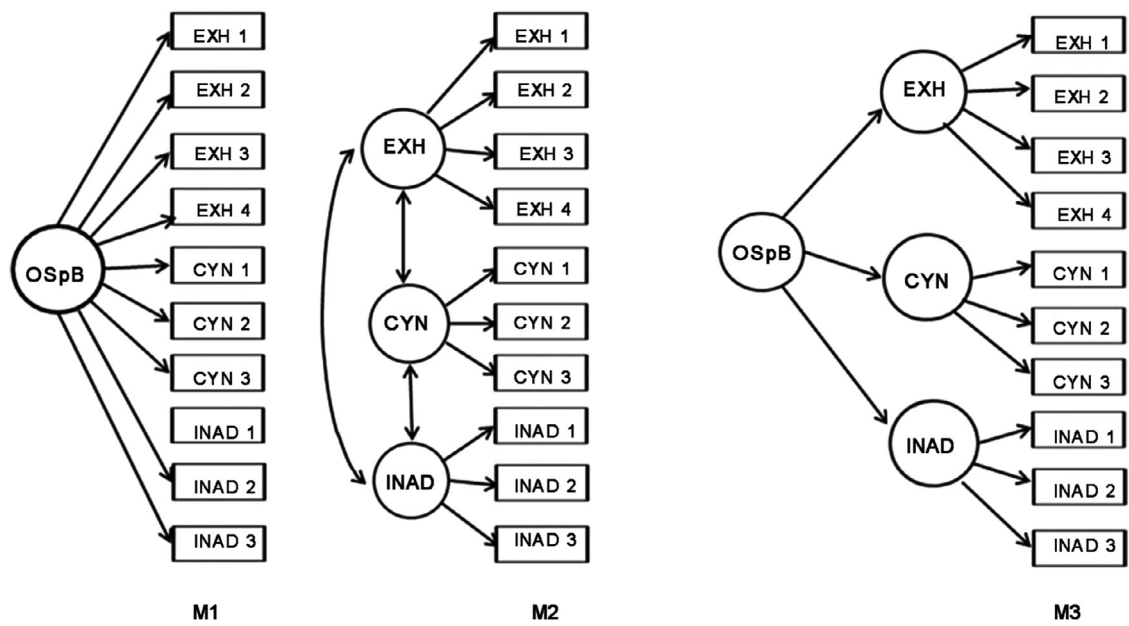

Fig. 1. The theoretical models of the Sport Burnout Inventory-Dual Career Form. CYN = cynicism; EXH = exhaustion; INAD = inadequacy; M1 = 1-factor model; M2 = correlated 3-factor model; M3 = second-order-factor model; OSpB = overall sport burnout.

was investigated by estimating Cronbach's  $\alpha$  reliabilities and factor score scale reliabilities (i.e., squared correlations between the latent factor and the factor score scale).

The fourth step was to investigate whether evidence of convergent and discriminant validity of SpBI-DC was shown by examining meaningful predictors of sport burnout. Consequently, depression, self-esteem, and motivation were added to the final M2 and M3 models, and paths from these predictors to the latent factors were estimated while accounting for gender and type of sport.

### 3. Results

#### 3.1. Structure of the SpBI-DC

The descriptive statistics and correlations between the SpBI-DC items are shown in Table 1.

We started the CFA by testing M1, which included all 10 items that measured different aspects of sport burnout (exhaustion, cynicism, inadequacy) as indicators of overall sport burnout. The goodness-of-fit indices for M1 were:  $\chi^2(35)=261.65$ ,  $p < 0.001$ ; CFI=0.75; TLI=0.68; RMSEA=0.13. Next, 3 correlated latent factors, that is, exhaustion (4 items), cynicism (3 items), and inadequacy (3 items), were assumed to underlie the items. The goodness-of-fit indices for M2 were  $\chi^2(32)=80.22$ ,  $p < 0.001$ ; CFI=0.95; TLI=0.93, RMSEA=0.06. Because correlations between the factors in M2 were relatively high (exhaustion, cynicism:  $r=0.48$ ,  $p < 0.001$ ; exhaustion, inadequacy:  $r=0.69$ ,  $p < 0.001$ ; cynicism, inadequacy:  $r=0.66$ ,  $p < 0.001$ ), we also investigated M3 consisting of a second-order factor of overall sport burnout and 3 first-order factors, namely, exhaustion, cynicism, and inadequacy. The goodness-of-fit indices for M3 were identical to M2, as the 2 models were data-equivalent.

The results showed that M1 did not fit to the data, but according to the goodness-of-fit indices M2 and M3 described the data well. Next, Satorra-Bentler scaled  $\chi^2$  test for difference was used to compare models M1 and M2/M3. The results showed, that the goodness-of-fit indices were superior in M2/M3 compared to M1,  $\chi^2_{\text{diff}}(3)=114.55$ ,  $p < 0.001$ . This

result suggests that sport burnout can be best described with a model that contains 3 related factors (M2), or as a model that contains 3 related factors that are explained by overall sport burnout (M3).

#### 3.2. Reliability and validity

The item reliabilities and factor loadings (i.e., standardized validity coefficients) are presented in Table 2. As shown in Table 2, the reliability and validity coefficients were lower for model M1 than for the other models. Furthermore, all of the items included in models M2 and M3 seemed to be good estimators of latent factors. The results indicate that models M2 and M3 show factorial validity and describe sport burnout as a phenomenon better than is shown by M1.

To examine internal consistency of the items in the 3 models, factor score scale reliabilities and Cronbach  $\alpha$  reliabilities were calculated. As shown in Table 3, all of the factor score scales had good internal consistency. Furthermore, factor score scale reliabilities, which take into account the weight of each item, were higher than the Cronbach's  $\alpha$  reliabilities. Factor score scale reliabilities were higher for M2 and M3 than for the 3 separate scales, which indicates that the 2 models (M2 and M3) show better internal consistency than the 3 separate scales (Table 2).

#### 3.3. Convergent and discriminant validity

The final step of the study was to investigate evidence of convergent and discriminant validity of the SpBI-DC by examining whether sport task-values, sport-related self-esteem, and depressive symptoms would predict sport burnout factors while accounting for gender and type of sport. Although M2 and M3 were both equally sufficient in describing the phenomenon of sport burnout, M3 was used as the final model because of its theoretical multiplicity.

First, the predictors were added to M3, and regression coefficients were estimated from sport task values, self-esteem, and depression for each latent factor (overall sport burnout, exhaustion, cynicism, and inadequacy). Only the statistically

Table 1  
Means, variances, and bivariate correlations between the raw score items of the SpBI-DC.

SpBI-DC items	1	2	3	4	5	6	7	8	9	10
1. EXH 1	—	0.33	0.31	0.28	0.34	0.32	0.24	0.29	0.21	0.41
2. CYN 1		—	0.30	0.19	0.64	0.54	0.31	0.16*	0.37	0.26
3. INAD 1			—	0.35	0.44	0.42	0.62	0.41	0.48	0.39
4. EXH 2				—	0.18*	0.22	0.39	0.51	0.30	0.39
5. CYN 2					—	0.58	0.40	0.26	0.39	0.33
6. CYN 3						—	0.37	0.29	0.36	0.31
7. INAD 2							—	0.44	0.47	0.30
8. EXH 3								—	0.32	0.61
9. INAD 3									—	0.38
10. EXH 4										—
Means	2.09	1.29	2.10	1.80	1.41	1.40	1.98	2.40	1.88	1.90
Variances	0.77	0.27	0.89	0.73	0.48	0.55	1.03	1.36	1.06	0.91

Note: \*  $p < 0.01$ , the other correlations were statistically significant ( $p < 0.001$ ).

Abbreviations: CYN = cynicism; EXH = exhaustion; INAD = inadequacy; SpBI-DC = Sport Burnout Inventory—Dual Career Form.

Table 2  
Estimated item reliability ( $R^2$ ), standardized factor loading coefficients (in parentheses), factor score scale reliabilities, and Cronbach's  $\alpha$  values for the models.

SpBI-DC items	M1				M2				M3			
	OspB	EXH	CYN	INAD	EXH	CYN	INAD	OspB	EXH	CYN	INAD	
EXH 1	0.23 (0.48)	0.20 (0.45)			0.22 (0.47)				0.22 (0.47)			
EXH 2	0.25 (0.50)	0.34 (0.59)			0.36 (0.60)				0.36 (0.60)			
EXH 3	0.35 (0.59)	0.64 (0.80)			0.62 (0.79)				0.62 (0.79)			
EXH 4	0.36 (0.60)	0.57 (0.76)			0.56 (0.75)				0.56 (0.75)			
CYN 1	0.33 (0.57)		0.59 (0.77)			0.55 (0.74)			0.55 (0.74)			
CYN 2	0.44 (0.66)		0.69 (0.83)			0.70 (0.84)			0.70 (0.84)			
CYN 3	0.40 (0.63)		0.49 (0.70)			0.51 (0.72)			0.51 (0.72)			
INAD 1	0.51 (0.71)			0.64 (0.80)			0.62 (0.79)				0.62 (0.79)	
INAD 2	0.45 (0.67)			0.59 (0.77)			0.57 (0.76)				0.57 (0.76)	
INAD 3	0.38 (0.62)			0.37 (0.61)			0.41 (0.64)				0.41 (0.64)	
EXH								0.50 (0.71)				
CYN								0.45 (0.67)				
INAD								0.96 (0.98)				
Factor score scale reliability	0.93	0.89	0.91	0.89	0.90	0.92	0.91	0.90	0.90	0.92	0.91	
Cronbach's $\alpha$	0.85	0.74	0.80	0.78								

Abbreviations: CYN = cynicism; EXH = exhaustion; INAD = inadequacy; M1 = 1-factor model; M2 = 3-factor model; M3 = second-order factor-model; OspB = overall sport burnout; SpBI-DC = Sport Burnout Inventory—Dual Career Form.

significant regression coefficients were included to the final model. The fit indices for the final model M3 were,  $\chi^2(61) = 137.85$ ,  $p < 0.01$ ; CFI = 0.94; TLI = 0.91; RMSEA = 0.06, which were considered acceptable. As shown in Fig. 2, the more depressive symptoms adolescents showed the more exhaustion they reported. Moreover, the higher self-esteem athletes reported, the less symptoms of overall sport burnout and exhaustion they reported. The higher sport interest values athletes had, the less symptoms of overall sport burnout and cynicism they reported. Finally, the higher sport utility values the athletes had, the less cynicism they reported. These results suggest that SpBI-DC has convergent and discriminant validity. Since gender, type of sport, and sport importance values were not significant predictors, the variables were excluded from the final model. As shown in Table 3, the sport importance value correlated negatively with overall sport burnout, cynicism, and inadequacy, but once all predictors were added to the same model, the relationship ceased to exist.

#### 4. Discussion

The present study introduced a new scale for measuring sport burnout symptoms shown by adolescent dual career athletes. The first aim of the study was to investigate the construct validity of SpBI-DC. As expected, a 3-factor model or a second-order-factor model described the data better than a 1-factor model. The results showed that exhaustion, cynicism, and inadequacy were closely related, but separate constructs, which could be explained by 3 positively correlated factors (M2), or by a second-order-factor (M3), in which exhaustion, cynicism, and inadequacy are first-order-factors explained by overall sport burnout. These results are in line with the findings of school-related burnout.<sup>21</sup>

The second aim of the study was to investigate reliability and validity of the SpBI-DC. The results showed that M2 and M3 had good factorial validity, and the 2 models described sport burnout as a phenomenon more reliably than M1. Furthermore, the models showed good internal consistency. Consequently, sport burnout can be measured as either 3 positively correlated factors, or as a secondary-factor-model that measures overall sport burnout.

There has been a debate in the literature whether burnout can be investigated outside work-context as a 3-dimensional construct.<sup>40,41</sup> Some researchers argue that burnout is explicit to work-context, because outside occupational settings, a person cannot identify “something” toward which they may feel inefficacious or cynical.<sup>40</sup> Bianchi and colleagues<sup>41</sup> suggested that exhaustion, cynicism, and inadequacy can occur in any context of chronic stress. Our results support this notion, and show that among student-athletes, sport burnout can be characterized by 3 separate dimensions, namely exhaustion, cynicism toward the meaning of sport, and feelings of inadequacy as an athlete. Similar findings have been found in other studies.<sup>12,22</sup>

Previously in sport settings sport burnout has been measured either as a single construct (combining the 3 subscales into a single score)<sup>42</sup> or as a 3-dimensional construct.<sup>12,17</sup> Measuring burnout as a single construct has been criticized for

Table 3  
Correlations between the latent factors of M3, predictors, and control variables.

	OSpB	EXH	CYN	INAD	Mean	Variance
Depressive symptoms	0.13	0.22*	-0.03	0.13	1.77	0.30
Self-esteem	-0.39**	-0.21*	0.06	-0.39**	3.76	0.38
Sport interest values	-0.46**	0.02	-0.39**	-0.46**	4.71	0.12
Sport importance values	-0.20**	0.11	-0.26*	-0.20**	4.53	0.22
Sport utility values	-0.28**	0.05	-0.31**	-0.28**	4.69	0.19
Gender <sup>a</sup>	-0.06	-0.07	0.03	-0.06	1.49	0.25
Type of sport <sup>b</sup>	0.01	0.10	0.01	0.01	1.50	0.25

Notes: <sup>a</sup> 1 = girl, 2 = boy; <sup>b</sup> 1 = individual, 2 = team; \*  $p < 0.01$ , \*\*  $p < 0.001$ .

Abbreviations: CYN = cynicism; EXH = exhaustion; INAD = inadequacy; M3 = second-order factor-model; OSpB = overall sport burnout.

not being interpretative of the results.<sup>17</sup> For example, in work-context, the exhaustion dimension may help discriminating those on sick-leave from those who are not.<sup>43</sup> Our results, however, suggest that sport burnout among student-athletes can be measured either as 3 separate factors or as 1 overall second-order factor depending on the research questions under concern. This kind of more flexible definition may be conceptually closer to the phenomenon. It has been recently argued that there are difficulties in the strict 3-dimensional definition of burnout.<sup>19,43</sup> According to the MBI manual of burnout, in order to be considered burned out, the 3 dimensions of burnout should appear simultaneously.<sup>40</sup> At the same time, however, the 3 subscales should be investigated as different and distinct dimensions with independent consequences and causes.<sup>40</sup> Consequently, there may not be correspondence between having 1 concept and 3 separate measures for it.<sup>19</sup> Due to these

definitional difficulties, new promising tools for measuring burnout have been developed in the occupational settings.<sup>19,44</sup> In other settings too, such as sport and school, there should be constant investigation for finding the best theoretically grounded and conceptually coherent tools for measuring burnout.

The third aim of the study was to investigate convergent and discriminant validity of SpBI-DC by investigating meaningful predictors. As anticipated, depressive symptoms were positively related to sport-related exhaustion in particular. This finding is in line with previous studies which have shown that depression is associated with exhaustion-dimension of burnout.<sup>30,31</sup> This can be explained by the fact that 1 symptom of depression is chronic fatigue.<sup>29</sup> As expected, self-esteem, on the other hand, was negatively related with exhaustion and overall sport burnout. This finding is supported by previous

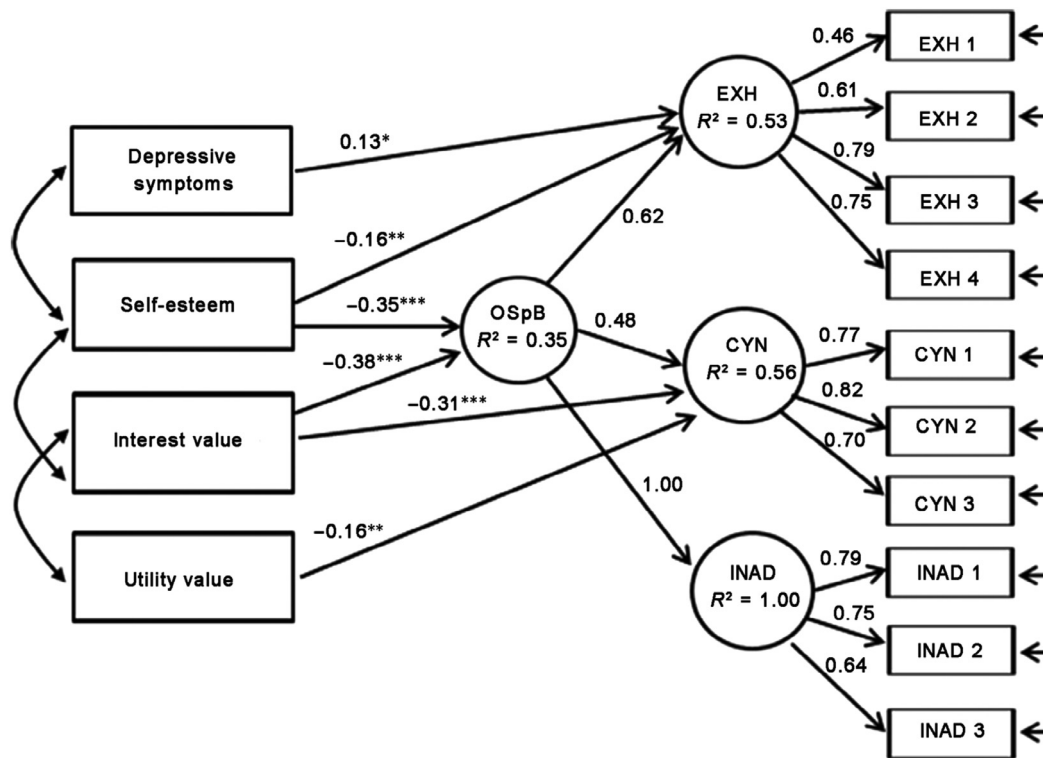

Fig. 2. Estimated M3 with predictors. Only the statistically significant regression coefficients are included. \*  $p < 0.05$ , \*\*  $p < 0.01$ , \*\*\*  $p < 0.001$ . CYN = cynicism; EXH = exhaustion; INAD = inadequacy; M3 = second-order factor-model; OSpB = overall sport burnout.



literature.<sup>27</sup> When athletes' results in sport deteriorate, or they feel inadequate and exhausted in their sport, their self-esteem is likely to decline. Finally, as anticipated, sport interest values were negatively related to overall sport burnout, and sport interest and sport utility values were negatively related to cynicism. These findings are in line with previous research suggesting that lack of motivation is associated with high levels of burnout.<sup>9,12</sup>

Interestingly, when all predictors were added to 1 model, sport importance value was not associated with sport burnout. It is possible that because the construct is closely related to interest and utility values, it has no independent effect on sport burnout. The fact that cynicism was particularly related to sport task values can reflect adolescents' attitude change. Indifferent or distal attitude toward sport may reflect lowered motivation characterized by lack of interest in sport and perceptions that the sport is no longer useful.

The present study had some limitations. First, the study was cross-sectional. It has been noted that sport burnout should be investigated longitudinally because it is a condition which evolves over time.<sup>45</sup> As the study was conducted in the autumn term of the first year of upper secondary sport school it is well possible that burnout symptoms related to the dual career path were under development. Future studies are needed to investigate the development and predictors of sport burnout across time and also take into account the possible impact of the sport season. Second, the SpBI-DC scale was investigated only in 1 cultural context: Finland. Consequently, there is a need to examine the properties of the scale also in other cultural settings and in other languages. Finally, in the present study the role of time devoted to sport on burnout was not specified because initial analyses showed a non-significant relationship ( $r = -0.09$ ,  $p = 0.08$ ). However, the question used to assess the amount of time spent on sport may have been limited, as it did not separate between time used on practicing and competitions and time spent in other activities related to sport participation (e.g., transportation). Because these 2 components can have a distinct impact on sport burnout, future studies are needed to examine their distinct role in sport burnout.

## 5. Conclusion

The present study introduced a novel instrument for examining sport burnout in adolescent dual career athletes. The SpBI-DC showed good structural validity and item and scale reliability. Furthermore, when estimated in the context of depressive symptoms, self-esteem, and sport task values, the SpBI-DC showed good discriminant and convergent validity, which indicated that SpBI-DC is a valid and reliable instrument for assessing adolescent student-athletes' sport burnout symptoms in a dual career context.

## Acknowledgment

This study was funded by grant from the Finnish Ministry of Education and Culture (No. OKM/13626/2015).

## Authors' contributions

TVR and HS collected the data and developed the concept and the questionnaire; KA helped with the data analysis and in developing the concept and the questionnaire; KS-A participated in designing the manuscript; MS conducted the data analysis and designed and wrote the manuscript with substantial input from the other authors. All authors have read and approved the final version of the manuscript, and agree with the order of presentation of the authors.

## Competing interests

The authors declare that they have no competing interests.

## References

- Rubin LM, Moses RA. Athletic subculture within Student-Athlete Academic Centers. *Sociol Sport J* 2017;1:1–36.
- Goévremont A, Findlay L, Kohen D. Organized extracurricular activities of Canadian children and youth. *Health Rep* 2008;19:65–9.
- Wylleman P, Lavalley D. A developmental perspective on transitions faced by athletes. In: Weiss M, editor. *Developmental sport and exercise psychology: a lifespan perspective*. Morgantown, WV: Fitness Information Technology; 2004.p.503–24.
- Stambulova NB, Wylleman P. Special issue: dual career development and transitions. *Psychol Sport Exerc* 2015;21:1–134.
- The EU Expert Group "Education and Training in Sport". *EU guidelines on dual careers of athletes: Recommended policy actions in support of dual careers in high-performance sport*. Available at: [http://ec.europa.eu/sport/news/20130123-euguidelines-dualcareers\\_en.htm](http://ec.europa.eu/sport/news/20130123-euguidelines-dualcareers_en.htm). [accessed 16.11.2012].
- Sorkkila M, Aunola K, Ryba TV. A person-oriented approach to sport and school burnout in adolescent student-athletes: the role of individual and parental expectations. *Psychol Sport Exerc* 2017;28:58–67.
- Isoard-Gauthier S, Guillet-Descas E, Gustafsson H. Athlete burnout and the risk of dropout among young elite handball players. *Sport Psychol* 2016;30:123–30.
- Bask M, Salmela-Aro K. Burned out to drop out: exploring the relationship between school burnout and school dropout. *Eur J Psychol Educ* 2013;28:511–28.
- Raedeke TD, Smith AL. Development and preliminary validation of an athlete burnout measure. *J Sport Exerc Psychol* 2001;23:281–306.
- Eades AM. *An investigation of burnout of intercollegiate athletes: the development of the eades athletic burnout inventory*. Berkeley, CA: University of California; 1990. [Masters' thesis].
- Fender LK. *Athletic burnout: a sport adaptation of the maslach burnout inventory*. Kent, OH: Kent State University; 1998. [Dissertation].
- Cresswell SL, Eklund RC. The convergent and discriminant validity of burnout measures in sport: a multi-trait/multi-method analysis. *J Sports Sci* 2006;24:209–20.
- Eklund RC, Defreese JD. Athlete burnout: what we know, what we could know, and how we can find out more. *Int J Appl Sports Sci* 2015;27:63–75.
- Gustafsson H, Defreese JD, Madigan DJ. Athlete burnout: review and recommendations. *Curr Opin Psychol* 2017;16:109–13.
- Maslach C, Jackson SE. *Maslach burnout inventory manual*. Palo Alto, CA: Consulting Psychologists Press; 1986.
- Raedeke TD, Smith AL. *The athlete burnout questionnaire manual*. 4th ed. Morgantown, WV: Fitness Information Technology; 2009.
- Gustafsson H, Lundkvist E, Podlog L, Lundkvist C. Conceptual confusion and potential advances in athlete burnout research. *Percept Mot Skills* 2016;123:784–91.
- Raedeke TD, Arce C, De Francisco C, Seoane G, Ferraces MJ. The construct validity of the Spanish version of the ABQ using a multi-trait/multi-method approach. *Anal Psicol* 2013;29:693–700.

19. Kristensen TS, Borritz M, Villadsen E, Christensen KB. The Copenhagen Burnout Inventory: a new tool for the assessment of burnout. *Work Stress* 2005;**19**:192–207.
20. Salmela-Aro K, Näätänen P. *BBI-10 School Burnout Inventory (Koulu-uupumusmittari)*. Helsinki: Edita; 2005. [in Finnish].
21. Salmela-Aro K, Kiuru N, Leskinen E, Nurmi J-E. School Burnout Inventory (SBI): reliability and validity. *Eur J Psychol Assess* 2009;**25**:48–57.
22. Goodger K, Gorely T, Lavallee D, Harwood D. Burnout in sport: a systematic review. *Sport Psychol* 2007;**21**:127–51.
23. Gustafsson H, Hill AP, Stenling A, Wagnsson S. Profiles of perfectionism, parental climate, and burnout among competitive junior athletes. *Scand J Med Sci Sports* 2016;**26**:1256–64.
24. Eccles JS. Subjective task value and the Eccles et al. model of achievement-related choices. In: Elliot AJ, Dweck C, editors. *Handbook of competence and motivation*. New York, NY: Guilford Press; 2005.p.105–21.
25. Gustafsson H, Hassmen P, Kentta G, Johansson M. A qualitative analysis of burnout in elite Swedish athletes. *Psychol Sport Exerc* 2008;**9**:800–16.
26. Harter S. *Construction of the self: developmental and sociocultural foundations*. 2nd ed. New York, NY: Guilford Press; 2012.p.22–4.
27. Cui HL, Zhang LC. Relationship between athlete's burnout and career satisfaction, self-esteem and source of mental control. *J Beijing Sport Univ* 2008;**31**:1237–9 in Chinese.
28. Maslach C, Jackson SE, Leiter MP. Maslach burnout inventory. In: Zalaquett CP, Wood RJ, editors. *Evaluating stress: a book of resources*. 3rd ed. London: The Scarecrow Press; 1997.p.191–218.
29. American Psychiatric Association. *Diagnostic and Statistical Manual of mental disorders V (DSM-V)*. Washington, DC: APA; 2013.p.296.
30. Salmela-Aro K, Savolainen H, Holopainen L. Depressive symptoms and school burnout during adolescence: evidence from two cross-lagged longitudinal studies. *J Youth Adolesc* 2009;**38**:1316–27.
31. Schaufeli WB, Enzmann D, Girault N. Measurement of burnout. In: Schaufeli WB, Maslach C, Marek T, editors. *Professional burnout: recent developments in theory and research*. Washington, DC: Taylor & Francis; 1993.p.199–215.
32. Rice F, Lifford KJ, Thomas HV, Thapar A. Mental health and functional outcomes of maternal and adolescent reports of adolescent depressive symptoms. *J Am Acad Child Adolesc Psychiatry* 2007;**46**:1162–70.
33. Cremades J, Wiggins M. *Direction and intensity of trait anxiety as predictors of burnout among collegiate athletes*. *J Sport Psychol* 2007;**10**. Available at: <http://www.athleticinsight.com/Vol10Iss2/TraitAnxiety.htm>. [accessed 07.07.2018].
34. Chalabaev A, Sarrazin P, Fontayne P, Boiche J, Clement-Guillot C. The influence of sex stereotypes and gender roles on participation and performance in sport and exercise: review and future directions. *Psychol Sport Exerc* 2013;**14**:136–44.
35. Ryba TV, Aunola K, Kalaja S, Selänne H, Ronkainen NJ, Nurmi J-E. A new perspective on adolescent athletes' transition into upper secondary school: a longitudinal mixed methods study protocol. *Cogent Psychol* 2016;**3**:1142412. doi:10.1080/23311908.2016.1142412.
36. Goodman R. The Strengths and Difficulties Questionnaire: a research note. *J Child Psychol Psychiatry* 1997;**38**:581–6.
37. Rosenberg M. *Society and the adolescent self-image*. Princeton, NJ: Princeton University Press; 1965.
38. Muthén LK, Muthén BO. *Mplus users' guide*. 7th ed. Los Angeles, CA: Muthén and Muthén; 2012.
39. Hu LT, Bentler PM. Cutoff criteria for fit indexes in covariance structure analysis: conventional criteria versus new alternatives. *Struct Equ Model* 1999;**6**:1–55.
40. Schaufeli WB, Leiter MP, Maslach C. Burnout: 35 years of research and practice. *Career Dev Int* 2009;**14**:204–20.
41. Bianchi R, Truchot D, Laurent E, Brisson R, Schonfeld IS. Is burnout solely job-related? A critical comment. *Scand J Psychol* 2014;**55**:357–61.
42. Ryu K, Kim J, Ali A, Choi S, Kim H, Radlo SJ. Comparison of athletes with and without burnout using the Strop Color and Word test. *Percept Mot Skills* 2015;**121**:413–30.
43. Schaufeli WB, Bakker AB, Hoogduin K, Schaap C, Kladler A. On the clinical validation of the Maslach Burnout Inventory and the Burnout Measure. *Psychol Health* 2001;**16**:565–82.
44. Halbesleben JRB, Demerouti E. The construct validity of an alternative measure of burnout: investigating the English translation of the Oldenburg Burnout Inventory. *Work Stress* 2015;**19**:208–20.
45. Chen LH, Kee YH, Tsai YM. An examination of the dual model of perfectionism and adolescent athlete burnout: a short-term longitudinal research. *Soc Indic Res* 2009;**91**:189–201.