

<https://helda.helsinki.fi>

py The development of student teachers sense of
agency in the classroom during teacher education

Heikonen, Lauri

2020

Heikonen , L , Pietarinen , J , Toom , A , Soini , T & Pyhältö , K 2020 , ' The development of
py student teachers sense of professional agency in the classroom durin
, Learning: Research and Practice , vol. 6, 2020 , no. 2 , pp. 114-136 . <https://doi.org/10.1080/23735082.2020.1725603>

<http://hdl.handle.net/10138/333397>

<https://doi.org/10.1080/23735082.2020.1725603>

unspecified

acceptedVersion

Downloaded from Helda, University of Helsinki institutional repository.

This is an electronic reprint of the original article.

This reprint may differ from the original in pagination and typographic detail.

Please cite the original version.

The development of student teachers' sense of professional agency in the classroom during teacher education

This manuscript has been accepted for publication in *Learning: Research and Practice* on November 11th, 2019.

Lauri Heikonen (corresponding author)

Centre for Educational Assessment

Faculty of Educational Sciences, University of Helsinki

P.O. Box 9 (Siltavuorenpenger 1B), 00014 University of Helsinki, Finland

lauri.heikonen@helsinki.fi, Tel. +358 50 3688008

Prof. Janne Pietarinen

School of Applied Educational Science and Teacher Education, University of Eastern Finland

P.O. Box 111 (Yliopistokatu 2), 80101 Joensuu, Finland

janne.pietarinen@uef.fi, Tel. +358 50 4650642

Prof. Auli Toom, Director

Centre for University Teaching and Learning

Faculty of Educational Sciences, University of Helsinki

P.O.Box 9 (Siltavuorenpenger 1A), 00014 University of Helsinki, Finland

Visiting Professor, Institute of Education, University of Tartu, Estonia

auli.toom@helsinki.fi, Tel. +358 50 4154852

Dr., Research Director, Tiina Soini

Faculty of Education and Culture, Tampere University

P.O. Box 700, FI-33014 Tampere University

tiina.soini-ikonen@tuni.fi, Tel. +358 40 1901753

Prof. Kirsi Pyhältö

Centre for University Teaching and Learning

Faculty of Educational Sciences, University of Helsinki

P.O.Box 9 (Siltavuorenpenger 1B), 00014 University of Helsinki, Finland

Professor of Educational Sciences, Faculty of Educational Sciences, University of Oulu, Finland

Extraordinary Professor, University of Stellenbosch, South-Africa

kirsi.pyhalto@helsinki.fi, Tel. +358 50 4150132

Abstract

Teacher education needs to facilitate the development of student teachers' capacity for active and skillful learning in classroom interaction, referred to as sense of professional agency in the classroom. It consists of motivation to learn, self-efficacy beliefs about learning, and strategies promoting one's own and pupils' learning in the classroom. However, not much is known about how student teachers' sense of professional agency in the classroom develops during teacher education. This longitudinal study investigated the interrelations between the components of Finnish student teachers' (N=268) sense of professional agency in the classroom during teacher education. Structural equation modeling was used to analyze the data that was collected annually during the bachelor's degree phase of primary school teacher education. The results showed that the construction of student teachers' sense of professional agency in the classroom was based on being able to interpret and analyze classroom interaction and became more strongly related to their abilities to use peers, more experienced teachers, and pupils as resources in constructing supportive collaborative learning environments and developing functional engaging teaching methods. The findings suggest that professional agency in the classroom is a functional integrative concept for investigating student teacher learning and developing teacher education.

Keywords

Teacher learning; professional agency; pre-service teachers, classroom interaction; instructional development

Introduction

In order to learn and thrive through future professional challenges, continuously construct one's teaching expertise and actively enhance pupils' learning, future teachers need to develop a sense of professional agency in the classroom during teacher education (Bronkhorst, Meijer, Koster, & Vermunt, 2011; Heikonen, Pietarinen, Pyhältö, Toom, & Soini, 2017; Niemi, Nevgi, & Aksit, 2016; Toom, Pietarinen, Soini, & Pyhältö, 2017). Professional agency in the classroom refers to a motivational-affective, intellectual and behavioral capacity that enables and prepares the ground for active intentional efforts towards enhancing reciprocal learning in classroom interaction (Toom et al., 2017). It is composed of motivation and self-efficacy beliefs for learning as well as skills and strategies for transforming and regulating teaching, learning and the environment (Edwards, 2005; Sachs, 2000; Pyhältö, Pietarinen, & Soini, 2015; Soini, Pietarinen, Toom, & Pyhältö, 2015; Turnbull 2002, 2005). In prior educational research, the notion of agency has been applied to describe individuals' commitment, active engagement and effort in relation to particular objects (e.g., educational innovation, social justice) and/or different contexts (e.g., system structures, curricular reforms, work community) (e.g., Lasky, 2005; Pantic, 2015). This study applies a specific definition of student teachers' professional agency in the classroom that aims to understand student teachers' active and skillful learning in the classroom context.

Student teachers' professional agency in the classroom develops through active intentional decision making and participation in organizing, adapting, and experimenting with instructional practices and the learning environment (Soini et al., 2015). This requires student teachers to expand their focus from the intrapersonal to the interpersonal level (Toom et al., 2017); thus providing experiences of being able to enhance pupils' learning through active modification of instructional practice according to one's analytic inferences made from surrounding interactions and events. These learning experiences provide student teachers with efficacy

beliefs and skills that contribute to their capacity to intentionally and accountably promote learning in the classroom (Evers, Brouwers, & Tomic, 2002; Jennings & Greenberg, 2009; Soini et al., 2015; Toom, et al., 2017; Wheatley, 2005).

Student teachers are found to learn in the classroom by reflecting on and analyzing classroom situations, modeling others' instructional strategies and ideas, experimenting and testing novel teaching methods, and interacting with others, including pupils, peers, and teacher educators (Kyndt, Gijbels, Grosemans, & Donche, 2016; Soini et al., 2015; Toom et al., 2017). However, the current understanding of student teachers' learning in classroom interaction is insufficient (Clarke & Hollingsworth, 2002; Korthagen, 2017; Leeferink, Koopman, Beijaard, & Ketelaar, 2015). Even less is known about the development of their sense of professional agency in the classroom during teacher education (Blömeke, Gustafsson, & Shavelson, 2015; Heikonen, Toom, Pyhältö, Pietarinen, & Soini, 2017; Soini et al., 2015; Toom et al., 2017). Therefore, this longitudinal study explores the interrelations between the components that constitute student teachers' sense of professional agency in the classroom during teacher education, including their perceptions of their capacity to reflect in the classroom, use others as resources in transforming instructional practice and the environment, and provide significant learning experiences for all.

Student teachers' sense of professional agency in the classroom

Professional agency in the classroom entails active, skillful, and intentional efforts to promote learning individually and together with pupils in the classroom (Pietarinen, Pyhältö, & Soini, 2016; Pyhältö, Pietarinen, & Soini, 2012; Soini et al., 2015). It is a capacity consisting of student teachers' motivation and self-efficacy beliefs for constant learning and development of instruction as well as persistent skillful regulation of classroom activities, interaction, and the

environment (Edwards, 2005; Sachs, 2000; Soini et al., 2015; Turnbull 2002, 2005). The concept of agency has been criticized as vague, abstract and devoid of explicit definitions, directions and operationalizations (Arnold & Clarke, 2014; Emirbayer & Mische, 1998; Eteläpelto et al., 2013; Pantic, 2015). In this study, professional agency is defined by determining learning as its object and considering it to be highly relational and context dependent (Edwards, 2005; 2007; Emirbayer & Mische, 1998; Greeno, 2006; Lipponen & Kumpulainen, 2011). Thus, it is an integrative concept comprising student teachers' cognitive, motivational-affective and behavioral resources for continuous professional development and promotion of pupils' learning in the classroom (Toom et al., 2017). These capacities are an integral part of each of the contextualized components of professional agency in the classroom that are presented next, based on prior literature on student teachers' active and skillful learning in the classroom interaction context.

Several studies have shown that active reflection in classroom situations is an important element of teacher learning in classroom interaction (Dunn & Shriner, 1999; Hoekstra, Brekelmans, Beijaard, & Korthagen, 2009; Kwakman, 2003; Lohman, 2006; Lohman & Woolf, 2001; Smaller, 2005; Van Eekelen, Boshuizen, & Vermunt, 2005). Reflection in the classroom refers to student teachers' analytic meaning-making of classroom interaction situations and essential features related to improving pedagogical practice (Eraut, 1995; Schön, 1987). Reflective skills contribute to student teachers' deliberate and analytic observations in classroom interaction, improve their learning to adopt observed instructional practices into their own teaching, facilitate integration of theory and practice, and enhance awareness of and the interplay between knowledge, beliefs, strategies, contextual and situational factors, and professional identity (Barnhart & van Es, 2015; Korthagen, Loughran, & Russell, 2006; Lunenberg, Korthagen, & Swennen, 2007; Sherin, Jacobs, & Philipp, 2011; Tilson, Sandretto, & Pratt, 2017; Toom, Husu, & Patrikainen, 2015). Moreover, active reflection enables student teachers to be more open to

pupils' initiatives, needs, and feedback, focus on pupils' learning processes instead of their own performance, and become aware of the relational schemas that guide their behavior in teacher-pupil encounters, thus enabling them to act more professionally by connecting with pupils and constructing collaborative learning in the classroom (Claessens et al., 2016; Crichton & Gil, 2015; Fuller & Bown, 1975).

Learning by modeling entails screening and analyzing others' professional actions and instructional strategies, getting ideas from others, and transforming them into one's professional expertise. It means seeking novel ways of acting and thinking by observing the essential features and consequences of teaching events (Barnhart & Van Es, 2015; Berliner, 2001; Edwards & Protheroe, 2003). Observing the instructional practices of peers and more advanced teachers has been shown to be a significant learning strategy for teachers that contributes to their perceived competence in teaching (Brown, Lee, & Collins, 2015; Cheng, Cheng, & Tang, 2010; Lieberman & Pointer Mace, 2009; Meirink, Meijer, Verloop, & Bergen, 2009). However, the development of a sense of professional agency in the classroom cannot be advanced merely by screening others' teaching. Learning by observing more accomplished teachers requires motivation and cognitive capacity for analyzing and transforming the ideas to fit one's professional practice and other contexts (Hagger & McIntyre, 2006; Järvelä, 1998; van Velzen, Volman, Brekelmans, & White, 2012).

Gaining a sense of professional agency in the classroom affords student teachers opportunities to actively construct collaborative learning environments by flexibly and responsively adapting pedagogical practices and the environment. This entails motivation and confidence in developing their interpersonal skills and implementing them in careful and dynamic coordination of the learning environment together with pupils (Pyhältö et al., 2012; Rogoff, Matusov, & White, 1996; Sachs, 2000; Soini et al., 2010; Turnbull, 2002, 2005). The development of teachers' interpersonal skills (e.g., constructing a functional climate) is not

always linear and student teachers have been shown to struggle in using pupils as a resource for developing and modifying their pedagogical practices and considering pupils' needs (Bronkhorst, Meijer, Koster, & Vermunt, 2014; Edwards & D'Arcy, 2004; Edwards & Protheroe, 2003; Heikonen, Toom et al., 2017; Stürmer, Seidel, & Holzberger, 2016). Successful experiences of constructing collaborative learning environments have been shown to contribute to student teachers' perceived competence in teaching (Beijaard, 1995; Rots, Kelchtermans, & Aelterman, 2012; Spilt et al., 2011).

Student teachers' perceived teaching competence comprises having the knowledge, skills, and strategies required for acting successfully as a teacher within the complexities of classroom interaction and continuously developing instruction (Blömeke et al., 2015; Toom et al., 2017). It entails student teachers' ability to construct a holistic view of pedagogical practices, teaching methods, pupils' understanding, and understand they relate to each other in particular situations and can be improved. It is crucial not only for student teachers' future professional development, well-being, and commitment to the profession, but also for pupils' agency development (Arnold & Clarke, 2014; Edwards, 2005; Heikonen, Pietarinen et al., 2017; Soini et al., 2015). Professional agency in the classroom is related to pupils' active learning through the quality of instruction; competent and pedagogically knowledgeable teachers provide more cognitively activating lessons and more support for learning; thus, they can enhance pupils' achievement and motivation (Baumert et al., 2010; Hashweh, 1987; Kunter et al., 2013). For example, it has been suggested that student teachers who have no experience of actively seeking and providing support are less likely to facilitate pupils' agency in their teaching (Edwards, 2005; Lipponen & Kumpulainen, 2011).

Accordingly, a sense of professional agency in the classroom is comprised of core components that have their own function in promoting student teachers' active and skillful learning: reflection in the classroom, modeling others' instructional practices, intentional facilitation of

collaborative learning environments, and perceived competence for teaching (Soini et al., 2015). The components of student teachers' sense of professional agency in the classroom are not innate, but learnable and thus teachable in teacher education and professional development programs (Blömeke et al., 2015; Kunter et al., 2013; Toom et al., 2017). A sense of professional agency in the classroom is constructed continuously in relation to context, the actions of others, and personal past experiences (Emirbayer & Mische, 1998; Greeno, 2006). It requires perceiving pupils as a central resource for learning and intentionally collaborating in reciprocal learning processes (Hakkarainen, Paavola, & Lipponen, 2004; Kwakman, 2003; Rogoff et al., 1996; Soini et al., 2010). A sense of professional agency in the classroom entails perceiving learning as an integrated element of teaching (Van Eekelen, Vermunt, & Boshuizen, 2006), considering instruction as a reciprocal process (Martin & Dowson, 2009), and regarding the quality of teacher-pupil relationships, giving and receiving mutual support and feedback as essential for teacher professional development (Edwards, 2005; Pyhältö et al., 2012; Spilt, Koomen, & Thijs, 2011).

Teacher education as a learning environment for student teachers' professional agency in the classroom

Student teachers entering teacher education have beliefs about teaching and learning based on their prior experiences, which might guide their actions in the classroom (Calderhead & Robson, 1991; Cheng et al., 2010; Conway, 2001; Lortie, 1975; Ng, Nicholas, & Williams, 2010). In addition to prior experiences, the cultures, social relations, learning environments, curriculum and pedagogical methods used in teacher education can either facilitate or hinder student teachers' sense of professional agency in the classroom (Donche & Van Petegem, 2009; Greeno, 2006; Edwards, 2005; 2007; Lipponen & Kumpulainen, 2011; Toom et al., 2017; Turnbull,

2005). Student teachers have been shown to especially value the practical aspects of learning in teacher education that contribute to their perceived competence in teaching (Saariaho, Pyhältö, Toom, Pietarinen, & Soini, 2016; Saloviita & Tolvanen, 2017; Tang, Cheng, & Wong, 2016). However, without a theoretical basis for pedagogical thinking, capacity to regulate one's learning in the classroom, and exhaustive support structures for reflection, early teaching experiences may be challenging or unsuccessful, and strengthen traditional beliefs about teaching and learning (Feiman-Nemser & Buchman, 1986; Donche, Endedijk & van Daal, 2015; Hagger, Burn, Mutton, & Brindley, 2008; Korthagen, 2010; Tang et al., 2016).

Reflecting skills are often emphasized in teacher education curriculums as they are considered to form the basis for student teachers' successful learning in the classroom by enabling them to identify their abilities and skills for reformulating and experimenting with pedagogical strategies in classroom situations (Crichton & Gil, 2015; Jennings & Greenberg, 2009; Soini et al., 2015). Furthermore, collaborative learning tasks and constructive learning environments, in which teacher educators perceive and treat student teachers as professional agents and future colleagues, have been suggested to contribute to student teachers' sense of professional agency in the classroom and their ability to promote agency among their future pupils (Heikkilä, Lonka, Nieminen, & Niemivirta, 2012; Rigelman & Ruben, 2012; Soini et al., 2015; Toom et al., 2017; Turnbull, 2005; Väisänen, Pietarinen, Pyhältö, Toom, & Soini, 2016). Altogether, facilitating the development of student teachers' sense of professional agency in the classroom during teacher education requires providing safe collaborative environments that trigger experiences of being able to see and enact 'alternative possible trajectories of action' (Emirbayer & Mische, 1998, p. 971) early in their studies (Rajuan, Beijaard, & Verloop, 2008; Soini et al., 2015).

It has been shown that first-year student teachers are less able to regulate their learning than third-year student teachers (Donche et al., 2015; Donche & van Petegem, 2009). However, it has also been suggested that learning in the context of teacher education, where academic

learning and learning from practice are intertwined, is more complex than in other academic higher education programs (Endedijk et al., 2014); thus, the development of professional agency in the classroom may not always be linear. Previous studies have emphasized that longitudinal research on the interrelations between the components of student teachers' sense of professional agency in the classroom during teacher education is rather insufficient and needed for informing interventions and teacher education programs in preparing student teachers for active lifelong learning in the classroom (e.g., Endedijk et al., 2014; Heikonen, Toom et al., 2017; de Vries, Jansen, Helms-Lorenz, & van de Grift, 2015).

Aim of the Study

This study aims to gain a better understanding of the complexity of student teacher learning by exploring the interrelations between the components of their sense of professional agency in the classroom during the three first years of teacher studies (i.e., during the bachelor's degree study phase). The focus is on the interrelations between student teachers' reported active reflection in classroom situations (REF), perceived ability to learn by modeling and observing others' instructional strategies (MOD), experienced capacity to flexibly and responsively construct a collaborative learning environment (CLE) and sense of teaching competence (COM) (Figure 1). Accordingly, the study aims to test the hypothesized interrelations between the components of student teachers' sense of professional agency in the classroom and investigate how these relations and the stability of the components develop during the bachelor's degree phase of teacher education. The following hypotheses were tested:

H1 Reflection in classroom (REF) correlates positively with both student teachers' perceived ability to learn by observing others' teaching practices (MOD) and their

experienced capacity to construct a collaborative learning environment together with pupils (CLE) in every study year [at time-points T1-T3] (Barnhart & van Es, 2015; Crichton & Gil, 2015; Sherin et al., 2011; Toom et al., 2015).

H2 Both ability to learn by observing others' instructional practices (MOD) and perceived capacity to responsively and adaptively construct a collaborative learning environment (CLE) correlate positively with student teachers' sense of teaching competence (COM) in every study year [at time-points T1-T3] (Barnhart & van Es, 2015; Berliner, 2001; Edwards & Protheroe, 2003; Salonen, Vauras, & Efklides 2005).

H3 The components of student teachers' sense of professional agency in the classroom (REF, MOD, CLE & COM) are relatively stable and can be predicted over time (Soini et al., 2015).

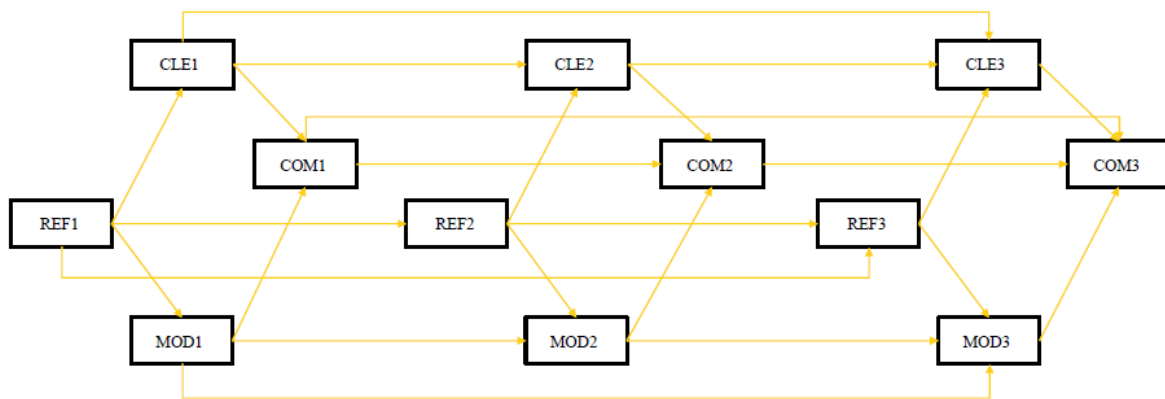

Figure 1. The hypothetical model of the interrelations between the components of student teachers' sense of professional agency in the classroom during the three first years in teacher education.

Methods

Research Context: Finnish Teacher Education

In Finland, primary school student teachers are a highly selected group of university students as only 5-11% of applicants are accepted to teacher education programs (VAKAVA, 2017). During the Bologna process in 2003-2006, the Finnish teacher education programs and curricula were aligned with the Bologna guidelines and systematized in terms of enhancing comparability and substitution among the eight universities responsible for educating primary school teachers (Jakku-Sihvonen & Niemi, 2006). Student teachers complete a master's degree in education, which is regulated by legislation of the Finnish Parliament (Ministry of Justice, 986/1998; 794/2004) and provides a formal qualification to teach in grades 1-6. The degree (300 European Credit Transfer and Accumulation System credits, see European Commission, 2014) is usually completed in five years and includes orientation studies (25 credits), main subject studies in educational sciences (140 credits), compulsory multidisciplinary studies in subjects taught in comprehensive school (60 credits) and optional studies including optional minor subject (75 credits). There are three student teaching periods that are spread throughout the studies: a practicum integrated with theoretical studies during the first study year, an intermediate practicum (12 ECTS, at university practice schools) at the end of bachelor degree phase and an advanced practicum (8 ECTS, mostly at municipal field schools) during the master degree phase (Niemi, 2016). The practicums are organized by the university at both the university practice schools owned by the state and at municipal field schools that collaborate with the university. Student teachers are guided by the mentor teachers working in the classroom and supervisors from the university, who visit, observe and reflect on the lessons together with them (Jyrhämä & Syrjäläinen, 2011). The main principle is that the practice periods enhance student teachers' professional growth by first emphasizing observation, then focusing on pupils' learning processes and finally providing a more holistic responsibility of

teaching (Niemi, 2016). The main subject studies also include writing a bachelor's degree thesis (during the third year) and a master's degree thesis (during the fourth or fifth year). In Finland, teacher education is highly research-based and aims to produce reflective pedagogical thinkers who approach teaching in an inquiring manner (e.g., Toom et al., 2010).

Participants

The survey data for this longitudinal study were collected annually in 2013, 2014 and 2015 from primary school student teachers at three universities in Finland. The participants had begun their studies in a five-year master's degree teacher education program in the fall 2012. Student teachers who answered the questionnaire in 2013 were included in the study setting the sample size at N=268 (response rate 82%). Again, in the second academic year, 59% of these student teachers participated and 64% responded to the questionnaire in the third year of their studies. Altogether N=125 of the student teachers participated in all three measurements. The sample in each repeated measure represented the student teacher population within the three universities (see Table 1). The distribution of participants into the three universities was moderately even, although one university was slightly overrepresented (48.5%; 31.0%; 20.5). Re-participation was related to age and gender as female students in the second year and older students in the third year were slightly more likely to be absent. However, non-response analysis showed no statistically significant differences between the responses of the ones who participated in every measurement and the ones who did not.

Table 1. Participants' gender and age in the first (T1), second (T2) and third academic year (T3).

		T1	T2	T3
Gender (N/%)	Female	209/78.0%	116/73.4%	127/74.3%
	Male	59/22.0%	42/26.6%	44/25.7%
Age	Min/Max	20/46	21/47	22/48
	Mean (SD)	23.95 (5.05)	24.26 (4.36)	25.12 (4.36)
	Median	22	23	24
	Mode	21	21	24

Most of the participants had none or less than six months of teaching experience (80%) and no prior degrees (77%). Permission to conduct the research was granted by the deans and directors of the institutes. Participants were informed about the research before the data collection and participation was voluntary. The paper-and-pencil survey was collected during regular teacher education courses in each institute. It took between 15 and 20 minutes to complete the questionnaire. The survey was sent via regular mail to those student teachers who were not present at the teacher education courses. They were asked to enter their responses to the questionnaire and return it to the university. There were no teacher-student relationships between the participants and the researchers.

Measures

The *Student teachers' professional agency* instrument (STPA) utilized in this study has been modified from the *Teachers' Sense of Professional Agency* survey (TPA) (Pietarinen, Pyhältö, Soini, & Salmela-Aro, 2013; Pyhältö, Pietarinen, & Soini, 2014; Soini et al., 2015). The instrument had been modified for student teachers and piloted in another teacher education

institute before the data collection (see Soini et al., 2015). The *student teacher professional agency in the classroom* scale was designed to measure central interrelated ingredients of student teachers' sense of professional agency in the classroom, including motivation to learn, self-efficacy beliefs for learning, and use of strategies for facilitating and enhancing learning in the classroom (Edwards, 2005; Sachs, 2000; Soini et al., 2015; Turnbull, 2002, 2005). The scale consisted of 20 items (see Appendix 1) that were all rated on a seven-point Likert scale reaching from 1 (completely disagree) to 7 (completely agree). The items measured four components of student teachers' sense of professional agency in the classroom: *Reflection in classroom* (REF) (five items); *Modeling* (MOD) (two items); *Collaborative learning environment* (CLE) (eight items), and *Competence* (COM) (five items). Due to the complexity of the longitudinal model and the limited number of participants, summated scales were used in the analysis. However, the scales have been applied as latent factor structures and validated in prior studies (Soini et al., 2015). The data that was used in this study is in the author's and the research group's possession, and can be accessed by contacting them.

Analysis

The descriptive statistics, reliability measures of each scale used in this study and missing value patterns were estimated with SPSS 24.0. The differences between the means of repeated measures of each scale were investigated with Friedman's nonparametric tests and the post-hoc pair-wise comparisons were conducted with Wilcoxon nonparametric tests, because of the non-normality of the data. Bonferroni correction was used to counteract the increased likelihood of type-one error related to multiple comparisons. There were less than two percent of missing data in each item and Little's MCAR test showed ($\chi^2=976.40$, $p=.16$) that missing data were

missing completely at random. Furthermore, chi-square tests of independence showed no statistically significant relations between the background variables and missing data.

Structural equation modeling (SEM) was used to test the longitudinal model. The analysis was carried out with Mplus version 7.11 (Muthén & Muthén, 1998–2012). A full information maximum likelihood (FIML) estimation procedure and robust estimator (MLR) were used to handle missing and non-normally distributed data. The goodness-of-fit of the estimated model was tested with a chi-square test (χ^2), Comparative Fit Index (CFI), Tucker Lewis Index (TLI), the Root Mean Square Error of Approximation (RMSEA), and Standardized Root Mean Square Residual (SRMR) (Hu & Bentler, 1999).

Results

All bivariate correlations between variables within time were statistically significant and in the expected direction, except modeling and collaborative learning environment in the second study year (at T2 between MOD2 and CLE2) (see Table 2). These correlations remained relatively stable during the three years indicating consistently separate but interrelated components of the *Professional agency in the classroom* construct. However, there was a tendency for the correlations to slightly decrease in the second year and then increase in the third year suggesting a more comprehensive investigation by means of SEM. The low correlations ($r=.11-.23$) between student teachers' sense of learning by observing others in authentic teaching situations (MOD) and their perceived ability to actively and responsively construct collaborative learning environment with pupils (CLE) in each year indicated that purely observing others in authentic teaching situations was not the dominant factor in terms of student teachers' experienced capacity to actively construct collaborative learning environment according to pupils' needs. The reliability measures produced Cronbach's alphas for the four scales in each measurement

(Table 2). The alphas consistently indicated sufficient reliability for *Reflection in classroom* ($\alpha=.67-.69$) and good reliability for all the other scales ($\alpha=.79-.89$).

Table2. Correlations, means and standard deviations of the variables used in the study.

Items	1.	2.	3.	4.	5.	6.	7.	8.	9.	10.	11.	12.
1. REF1	1.00											
2. REF2	.58**	1.00										
3. REF3	.40**	.56**	1.00									
4. MOD1	.30**	.25**	.27**	1.00								
5. MOD2	.20*	.28**	.17	.27**	1.00							
6. MOD3	.13	.26**	.42**	.23**	.42**	1.00						
7. CLE1	.45**	.26**	.12	.23**	.10	.03	1.00					
8. CLE2	.16*	.36**	.09	.10	.11	.13	.57**	1.00				
9. CLE3	.18*	.36**	.48**	.24**	.18*	.23**	.48**	.55**	1.00			
10. COM1	.28**	.30**	.21**	.32**	.28**	.12	.62**	.47**	.43**	1.00		
11. COM2	.20*	.34**	.27**	.25**	.30**	.21*	.35**	.52**	.45**	.57**	1.00	
12. COM3	.09	.31**	.42**	.13	.27**	.38**	.26**	.38**	.63**	.41**	.56**	1.00
Mean	6.17	6.18	6.25	5.96	5.72	5.84	4.93	4.95	5.23	4.57	4.75	5.07
SD	.60	.56	.54	.82	.93	.91	.73	.69	.59	.91	.76	.68
Min	1.20	4.40	4.60	3.50	2.00	2.00	2.38	2.88	3.25	2.20	2.00	3.20
Max	7.00	7.00	7.00	7.00	7.00	7.00	6.63	6.25	6.63	6.40	6.80	6.60
Cronbach's α	.69	.67	.68	.79	.89	.85	.84	.85	.82	.87	.82	.80

Note: * $p < 0.05$, ** $p < 0.01$

Student teachers perceived their capacity to reflect in the classroom (REF), including deliberate and systematic meaning making of teaching situations, ability to understand pupils' thinking and act as a facilitator of their learning in the classroom as significantly high (T1: $M=6.17$; T2: $M=6.18$; T3: $M=6.25$) during the three years of their studies. Student teachers' constant and

active reflection remained relatively stable during the first three years in teacher education as the means of repeated measures did not differ statistically significantly. Student teachers also considered modeling (MOD), consisting of observing more experienced teachers and peers in authentic teaching situations, an effective strategy for learning in the classroom during the three academic years (T1: M=5.96; T2: M=5.72; T3: M=5.84). The relatively high means for learning by getting ideas from others' instructional practices remained stable as there were no statistically significant differences among the repeated measures.

Further investigation showed that student teachers' perceived ability to construct a collaborative learning environment in the classroom (CLE), including creating and maintaining functional relationships with pupils and adapting pedagogical practices according to their learning needs, increased statistically significantly ($\chi^2=39.80$, $p<.001$) during the three first years of their studies (T1: M=4.93; T2: M=4.95, T3: M=5.23). Student teachers' perceived capacity to build functional participative interaction together with pupils increased particularly during the third academic year in teacher education as the mean of the T3 measurements differed statistically significantly from the T1 ($Z=-5.85$, $p<.001$) and from the T2 ($Z=-4.79$, $p<.001$). Student teachers' perceived competence for teaching (COM), including having extensive knowledge and skills on how to evaluate one's instructional choices and develop and utilize novel functional teaching methods, increased statistically significantly ($\chi^2=45.39$, $p<.001$) during the first three years in teacher education (T1: M=4.57; T2: M=4.75; T3: M=5.07). Student teachers' sense of competence in teaching developed constantly already from the beginning of their studies as the means differed statistically significantly from each other at all three time-points (T1-T2: $Z=-4.10$, $p<.001$; T2-T3: $Z=-4.47$, $p<.001$; T1-T3: $Z=-6.40$, $p<.001$).

Overall, the descriptive statistics showed that student teachers perceived to actively regulate their learning in the classroom in terms of critical evaluation in classroom situations (REF) and finding novel instructional strategies by observing authentic teaching (MOD) already during

the first years in teacher education. During this time, student teachers constructed their sense of professional agency in the classroom, including their perceived ability to flexibly adapt and transform the learning environment according to pupils' needs (CLE) and a comprehensive sense of understanding of how to continually develop instructional methods (COM).

The interrelations between the components of student teachers' sense of professional agency in the classroom during the first three years in teacher education

Structural equation modeling was used to test the consistency of the interrelations between the perceived learning capacities that comprise sense of professional agency in the classroom, including active reflection for learning (REF), learning by modeling (MOD), construction of collaborative learning environment (CLE) and teaching competence (COM). The results confirmed that the tested theoretical model fitted the data (see Figure 2). The goodness-of-fit indices (except the χ^2 -test) showed a good model fit.

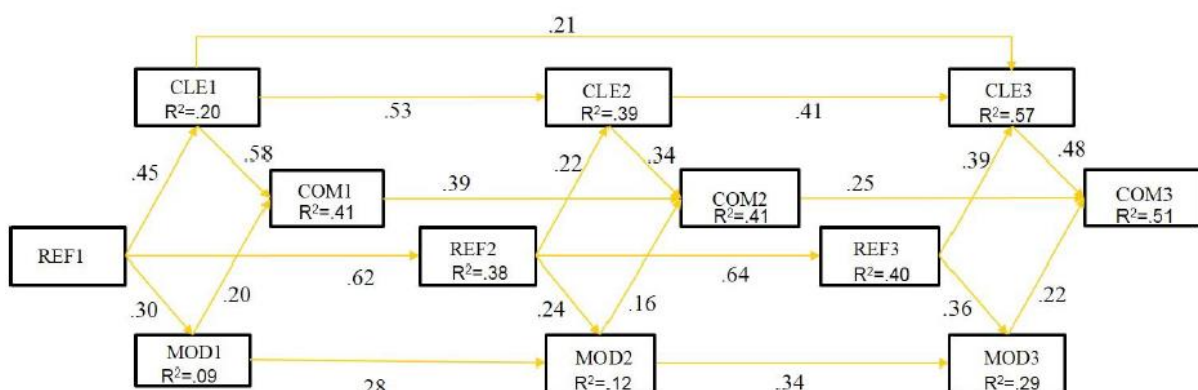

Figure 2. Standardized model: χ^2 (44, N = 268) = 89.20, $p < .001$, CFI = .94, TLI = .91, RMSEA = .06 (90% CI = .04 - .08), SRMR = .08. All parameters were significant at p level $< .05$, except

ns. = not significant. Note: One [autocorrelative] residual covariance of an observed variable was added.

The tested theoretical model confirmed (see Figure 2) that student teachers' willingness to actively reflect in the classroom (REF) was positively and consistently associated with their experienced learning by analyzing more advanced teachers in authentic classroom situations and modeling their teaching (MOD) in each academic year (T1=.30; T2=.24; T3=.36). Student teachers' motivation and ability to deliberately reflect in teaching situations became more strongly related to learning from observing others' instructional practices as their studies progressed. The tested model further confirmed that student teachers' critical and reflective meaning making in classroom events (REF) correlated with their ability to responsively and adaptively regulate and construct supportive and engaging classroom interaction (CLE) at all three time-points (T1=.45; T2=.22; T3=.39). Active reflection in classroom situations was associated with student teachers' ability to reciprocally construct collaborative learning environment in the classroom less during the second academic year compared to the first and third years of their studies. This indicated that the relatively strong but intricate correlation between student teachers' eagerness and ability to analyze and find meaning in classroom events and their capacity to responsively adapt the environment to create participative interaction revived in the third year. Hence, the results confirmed the H1.

The results further showed that student teachers' learning by observing authentic teaching situations and applying observed instructional strategies (MOD) was consistently and positively associated with student teachers' perception of having the skills and knowledge required for active transformation and development of teaching methods (COM) at all three measurement points (T1=.20; T2=.16; T3=.22). There was a slight increase in the moderate relation between

learning by modeling others' instructional strategies and student teachers' competence for teaching. Moreover, the tested model confirmed that student teachers' ability to adapt and build a collaborative learning environment by being supportive, flexible, and responsive towards pupils' needs and ideas (CLE) was relatively strongly related to student teachers' perceived teaching competence (COM) within the three academic years ($T1=.58$; $T2=.34$; $T3=.48$). The positive relation between student teachers' ability to promote reciprocal participative learning environments and their capacity to develop and experiment with various functional teaching methods was smaller in the second year than in the first and third study years. This indicated that student teachers' self-efficacy beliefs and abilities related to responding to pupils' learning needs by enhancing the quality of classroom interaction was strongly related to, but did not develop hand-in-hand with their teaching competence. These results confirmed H2.

Stability of components of student teachers' sense of professional agency in the classroom

The results confirmed that student teachers' sense of professional agency in the classroom, including reflection for learning in the classroom (REF), learning by observing and modeling more experienced teachers (MOD), constructing and adapting collaborative learning environment (CLE) and perceived teaching competence (COM), was relatively stable through the academic years (see Figure 2). However, the results showed that student teachers' ability to construct a collaborative learning environment in the classroom (CLE) was more predictable than the other components of professional agency in the classroom, since it was the only one with a statistically significant autoregressive effect between time one and time three ($T1-T2=.53$; $T2-T3=.41$; $T1-T3=.21$). Accordingly, this indicated that student teachers' capacity to facilitate functional participative interaction with pupils and construct a supportive learning environment

in the classroom during the first year also predicted their motivation, efficacy beliefs, and strategies for promoting their own and pupils' learning in the classroom later in their studies.

Further investigation showed that student teachers' reflection in pedagogical situations (REF) remained relatively stable, as their motivation, self-efficacy beliefs and skills for analyzing and evaluating classroom events predicted their reflective stance towards learning in the classroom in the following year ($T1-T2=.62$; $T2-T3=.64$). The tested model further showed that student teachers' learning by observing more experienced teachers in authentic classroom situations (MOD) was moderately stable and became more dependent on the previous year as their studies proceeded ($T1-T2=.28$; $T2-T3=.34$). Moreover, student teachers' competence in terms of the knowledge and skills required for developing teaching (COM) became less dependent on the level of perceived self-efficacy and strategies for cultivating and using novel teaching methods during the previous year ($T1-T2=.39$; $T2-T3=.25$). That is, student teachers' self-efficacy beliefs and skills for mastering, adapting, and developing teaching methods according to situational needs, which was a central increasing element of sense of professional agency in the classroom, became more dynamic simultaneously with becoming more strongly related to their capacity to use other teachers and pupils as resources for developing teaching expertise.

Discussion

Methodological Reflections

The study utilized survey data that were collected annually from primary school student teachers during the first three years of their teacher education studies. Data were collected from three different universities in Finland and covered the entire bachelor's degree phase of the master's degree teacher education program. The study responds to the need for more longitudinal research on student teacher learning in the classroom during teacher education (e.g.

Endedijk et al., 2014). However, the limitations of this study should be noted. First, the self-report data covered only student teachers' perceptions. Therefore, it is not certain whether the study revealed student teachers' ability to enact professional agency in real-life classroom situations. Although behavioral data (e.g., observations, videos) were not included, this study may have captured a general view of their sense of professional agency in the classroom. Secondly, despite elaborate development work with the instrument, there is a possibility for social desirability bias when collecting self-report data. However, data collection was conducted face-to-face during teacher education courses that researchers were not involved with, without the responsible teachers being present in the room and by trying to provide a safe environment for respondents (e.g., non-evaluative, secured anonymity). Thirdly, although the response rates in the study were not optimal, they were sufficient. A fourth limitation was that the scales that measured the different components of professional agency in the classroom consisted of a different amount of items, ranging from two to eight. Further development of the novel instrument is required, especially in terms of student teachers' learning through modeling other teachers that was measured with a scale consisting of only two items. In addition, the reliability estimates for the scale measuring student teachers' reflection in the classroom were partly on the generally agreed lower level of acceptance (i.e., $\alpha > .70$) (Hair, Black, Babin & Anderson, 2014), which indicates a need for adjusting the items in order to increase the consistency of the scale. Accordingly, in future studies, the instrument and bigger longitudinal data settings should be further developed in order to apply latent factor structures in variable-centered analysis and complex parameter estimation, investigate their measurement invariance and examine how the construct of professional agency in the classroom develops over time (e.g. during the transition to working-life). Furthermore, the scales of this research have not been used in other cultural contexts; thus, the generalizability of the findings should be cautiously considered.

Results in Light of Previous Literature

This study investigated the relationships between the components of a sense of professional agency in the classroom and their development during the three first years of teacher education studies. The results showed that student teachers' willingness to reflect was positively associated with their learning to utilize the observed functional teaching practices of more experienced teachers. This is in line with earlier studies (Eraut, 2007; Lunenberg et al., 2007) that suggested that the ability to deliberately and critically consider and analyze one's own professional practice and systematically make sense of teaching situations is needed for adapting others' instructional practices into one's pedagogical expertise. To be able to learn by observing others in authentic teaching situations requires reflective skills that direct student teachers' attention to significant elements of classroom interaction and enable them to become aware of their own beliefs, pupils' actions, teachers' strategies, pedagogical tools used and the environment. Learning occurs not only by observing experts and their teaching, but also by modeling, that requires active, deliberate and transformative efforts that need to be facilitated and supported during teacher education studies (Mena, Hennissen, & Loughran, 2017). The transformative power of the object-oriented activity in learning by observing lies in the active adaptation of the observed practices and ideas and in one's own creation and regulation of new teaching-learning experiences (Naidoo & Kirch, 2016). Thus, learning by observing others should be considered an intentional, experimental and open-minded process for which the ability to actively and critically reflect in the classroom is a prerequisite.

Moreover, the results showed that student teachers' reflective stance in the classroom was positively related to their experienced ability to build functional interaction with pupils and adapt the learning environment according to their learning needs in all three years. This

confirms previous findings showing that learning to actively reflect on pedagogical practice enables student teachers to focus more profoundly on pupils' learning processes instead of their own behavior and performance (Crichton & Gil, 2015; Fuller & Bown, 1975). For student teachers, a motivated and analytical stance towards their own professional learning in the classroom seems to enable them to develop sensitivity towards pupils' initiatives, adapt the learning environment accordingly, and engage all pupils to participate in co-learning (Edwards & Protheroe, 2003).

Further investigation showed that the positive correlation between student teachers' perceived capacity to critically analyze classroom interaction and their sensed ability to construct supportive, engaging learning environments for pupils showed a tendency to decrease during the second year, while it revived in the third year. This phenomenon has not been previously studied to the extent that it was here, although earlier research has suggested that the construction of professional agency is not a strictly linear process (Boshuizen, 2004; Endedijk et al., 2014; Postareff, Lindblom-Ylänne, & Nevgi, 2007). It seems that already during teacher education studies, the first experiences of working in the classroom may produce a reality check for student teachers (e.g. Veenman, 1984), who must then adjust their beliefs about what constitutes successful teaching and the complexities of classroom work. In the first year, student teachers already have skills and knowledge on how to reflect on their own learning as students, but as they gain experiences of learning and teaching in the classroom, their attention typically redirects to the demands of the classroom interaction context. Early experiences of teaching may focus student teacher reflection towards survival; thus, student teachers may not efficiently learn to adapt the classroom environment according to pupils' learning needs (Ng et al., 2010). Although student teachers' sense of professional agency in the classroom does not necessarily decrease, the object of activity may become temporally self- or survival-oriented because of the situational demands faced in classroom interaction. Their beliefs about what constitutes optimal

and functional teaching practice are still evolving and the theoretical basis and conceptual tools for pedagogical thinking are under construction, which affects their reflection in teaching-learning situations. When student teachers become aware of their reflective skills and focus them on analyzing and optimizing pupils' learning processes, reflection begins to contribute even more to their ability to build functional relationships with pupils and construct collaborative learning environments (Crichton & Gil, 2015). Thus, the first years in teacher education seem to comprise an important learning phase where student teachers are vulnerable, but build confidence (Klassen & Chiu, 2011; Pfitzner-Eden, 2016) and professional agency in the classroom by shifting their focus towards both their own learning and that of their pupils' (Conway & Clark, 2003), which further enables active construction of functional classroom environment.

The results showed that learning by observing others' teaching practices was positively associated with student teachers' perceived competence for teaching within the three first years in teacher education. This aligns with prior research showing that teachers perceive getting ideas from screening more advanced teachers and peers in authentic classroom situations as a valuable learning strategy that provides them with functional instructional methods especially at the beginning of their careers (Grosemans, Boon, Verclairen, Dochy, & Kyndt, 2015; Richter, Kunter, Klusmann, Lüdtke, & Baumert, 2011). It seems that student teachers' perceived capacity to learn from peers and more experienced colleagues leading to transformation of teaching practice seems to produce experiences of competence development that enhance their sense of professional agency in the classroom. Prior studies have highlighted the importance of the actions teacher educators take to model and discuss functional classroom practices (Lieberman & Pointer Mace, 2009; Meirink et al., 2009; Scales et al., 2017; van Velzen et al., 2012). Seeing the affordances of particular instructional choices may encourage student teachers to test novel strategies independently (Shaughnessy & Boerst, 2017). However, the

results of this study emphasize that in addition to modeling various instructional strategies, and making their everyday decision making explicit, teacher educators need to perceive student teachers as active learners, and, when necessary, support the learning processes in which student teachers critically analyze and express their observations and discuss ways in which their learning will be implemented in the classroom. Furthermore, more information is needed on the social strategies that student teachers use to navigate places for active experimental learning with observed ideas and methods and how they adapt them to their professional expertise despite contextual constraints (Gratch, 2001; Roberts & Graham, 2008; Tang et al., 2016).

Student teachers' perceived ability to adapt the learning environment to facilitate collaborative learning in the classroom correlated positively with their sense of having the knowledge and skills required for successful teaching and continuous instructional development. Learning co-regulative skills that enable them to enhance the atmosphere, construct reciprocal teacher-pupil relationships, and adapt the environment and interaction to meet the needs of all pupils despite the fast pace of classroom work seem to provide the essential experiences of mastery and control that are strongly related to student teachers' perceived competence for teaching. The results further showed that these reported abilities were more stable than the other components of student teachers' sense of professional agency in the classroom. This suggests that student teachers' perceived capacity to sensitively and responsively construct collaborative learning environment requires not only reflection skills, but also prior experiences of constructing functional classroom environment that yields co-learning. However, the results also confirmed that it is a learnable capacity that evolves already during teacher education studies.

A novel finding of the study was that during the second year of their studies, student teachers' sense of teaching competence, including perceived capacity to adapt and experiment with new teaching methods, became temporarily less related to student teachers' motivation and self-efficacy beliefs for constructing supportive participative interaction in the classroom. The result

indicates that learning to utilize and vary instructional methods according to different contents might demand student teachers' attention and leave less room for attending to the learning environment at the beginning of the studies. In the third year, their sense of competence for teaching again strongly correlated with their perceived ability to construct collaborative engaging learning environments and became less dependent on their experiences of teaching competence in the previous year.

It seems that when student teachers gain more practical knowledge and experiences of teaching and learning within the complexities of classroom interaction, their beliefs and assumptions of what constitutes and is needed for successful teaching change (Blömeke, Buchholtz, Suhl, & Kaiser, 2014). At the same time, their experiences of being able to develop teaching become more strongly related to learning by observing others' in authentic teaching situations and experiences of creating supportive interaction, and adapting the environment to yield collaborative learning. Accordingly, student teachers' sense of teaching competence becomes more related to their perceived capacities to use peers, mentors, teacher educators and pupils as resources in transforming teaching and creating functional learning environments when they construct their sense of professional agency in the classroom.

This study provides evidence that teacher education can facilitate the slow and complex processes in which student teachers construct their sense of professional agency in the classroom. There is a need to explore the individual trajectories of student teachers' sense of professional agency in the classroom during teacher education, which is under investigation by the research group (Pyhältö et al., submitted). However, the developmental changes in student teacher learning are not always permanent (Endedijk et al., 2014); therefore, more longitudinal studies are needed to investigate the construction of student teachers' professional agency during longer periods that capture the challenging transition to working at school. In addition, further research is needed on the mentoring strategies that foster the skills and qualities of

reflection that enhance student teachers' intentional learning from others, their sensitivity towards pupils' learning needs, and their ability to adapt their instructional practices accordingly during teacher education and the challenging early years in the profession (Mena et al., 2017).

Implications for Developing Teacher Education

The results showed that the development of sense of professional agency was based on student teachers' analytic stance towards classroom interaction, their perceived capacity to intentionally learn by observing others' instructional practice, and their sensed ability to actively construct functional collaborative learning environments. Learning opportunities tied to a classroom interaction context and the practice of teaching are especially important in providing experiences of autonomous and successful learning that contribute to teaching competence. However, it has been shown that the university-based courses in teacher education programs provide few opportunities for student teachers to analyze pupils' learning, see models of teaching, and enact, simulate and rehearse the practice of teaching (Jenset, Klette & Hammerness, 2017). These efforts to ground teacher education pedagogies into practice need to be advanced to provide each student teacher with experiences of developing professional agency in classroom interaction.

The study also showed that as student teachers' studies proceeded, their sense of competence in teaching became more related to their perceived abilities to learn by observing other teachers and to their experienced capacity to construct participative environments according to pupils' needs. Preparing student teachers to become active professional agents in the classroom requires securing versatile opportunities to learn to use others as resources in developing teaching (Edwards, 2005; 2007; Edwards & D'Arcy, 2004; Pyhältö et al., 2012). This capacity

for active, skillful and relational learning within the fast pace of classroom interaction can be practiced in teacher education through well-crafted instructional activities that include opportunities to observe and analyze teaching, elicit pupils' thoughts and motivational-affective states, and rehearse responses to their needs and co-regulation of their learning (Kazemi, Ghouseini, Cunard, & Turrou, 2016; McDonald, Schneider & Kavanagh, 2013). The concept of professional agency in the classroom could be useful in the discussions where those instructional activities are determined and merged with the visions of various stakeholders of teacher education and the different settings and phases of the programs.

Funding

This work was supported by the Academy of Finland under Grant 1259489 and the Finnish Academy of Science and Letters under Grant Jutikkala.

References

- Arnold, J., & Clarke, D. J. (2014). What is 'agency'? Perspectives in science education research. *International Journal of Science Education*, 36(5), 735-754.
- Barnhart, T., & van Es, E. (2015). Studying teacher noticing: Examining the relationship among pre-service science teachers' ability to attend, analyze and respond to student thinking. *Teaching and Teacher Education*, 45, 83-93.
- Baumert, J., Kunter, M., Blum, W., Brunner, M., Voss, T., Jordan, A., ... & Tsai, Y. M. (2010). Teachers' mathematical knowledge, cognitive activation in the classroom, and student progress. *American Educational Research Journal*, 47(1), 133-180.
- Beijaard, D. (1995). Teachers' prior experiences and actual perceptions of professional identity. *Teachers and Teaching*, 1(2), 281-294.
- Berliner, D. C. (2001). Learning about and learning from expert teachers. *International Journal of Educational Research*, 35(5), 463-482.
- Blömeke, S., Buchholtz, N., Suhl, U., & Kaiser, G. (2014). Resolving the chicken-or-egg causality dilemma: The longitudinal interplay of teacher knowledge and teacher beliefs. *Teaching and Teacher Education*, 37, 130-139.
- Blömeke, S., Gustafsson, J., & Shavelson, R. J. (2015). Beyond dichotomies: Competence Viewed as a Continuum. *Zeitschrift Für Psychologie*, 223(1), 3-13.
- Boshuizen, H. P. (2004). Does practice make perfect? In *Professional learning: Gaps and transitions on the way from novice to expert* (pp. 73-95). Springer Netherlands.

- Bronkhorst, L. H., Meijer, P. C., Koster, B., & Vermunt, J. D. (2011). Fostering meaning-oriented learning and deliberate practice in teacher education. *Teaching and Teacher Education, 27*(7), 1120-1130.
- Bronkhorst, L. H., Meijer, P. C., Koster, B., & Vermunt, J. D. (2014). Deliberate practice in teacher education. *European Journal of Teacher Education, 37*(1), 18-34.
- Brown, A. L., Lee, J., & Collins, D. (2015). Does student teaching matter? Investigating pre-service teachers' sense of efficacy and preparedness. *Teaching Education, 26*(1), 77-93.
- Calderhead, J., & Robson, M. (1991). Images of teaching: Student teachers' early conceptions of classroom practice. *Teaching and teacher education, 7*(1), 1-8.
- Cheng, M. M., Cheng, A. Y., & Tang, S. Y. (2010). Closing the gap between the theory and practice of teaching: Implications for teacher education programmes in Hong Kong. *Journal of Education for Teaching, 36*(1), 91-104.
- Claessens, L., van Tartwijk, J., Pennings, H., van der Want, A., Verloop, N., den Brok, P., & Wubbels, T. (2016). Beginning and experienced secondary school teachers' self-and student schema in positive and problematic teacher–student relationships. *Teaching and Teacher Education, 55*, 88-99.
- Clarke, D., & Hollingsworth, H. (2002). Elaborating a model of teacher professional growth. *Teaching and Teacher Education, 18*(8), 947-967.
- Crichton, H., & Valdera Gil, F. (2015). Student teachers' perceptions of feedback as an aid to reflection for developing effective practice in the classroom. *European Journal of Teacher Education, 38*(4), 512-524.

- Conway, P. F. (2001). Anticipatory reflection while learning to teach: From a temporally truncated to a temporally distributed model of reflection in teacher education. *Teaching and Teacher Education, 17*(1), 89-106.
- Conway, P. F., & Clark, C. M. (2003). The journey inward and outward: A re-examination of Fuller's concerns-based model of teacher development. *Teaching and teacher education, 19*(5), 465-482.
- de Vries, S., Jansen, E. P. W. A., Helms-Lorenz, M., & van de Grift, W. J. C. M. (2015). Student teachers' participation in learning activities and effective teaching behaviours. *European Journal of Teacher Education, 38*(4), 460-483.
- Donche, V., & Van Petegem, P. (2009). The development of learning patterns of student teachers: A cross-sectional and longitudinal study. *Higher Education, 57*(4), 463-475.
- Donche, V., Endedijk, M. D., & van Daal, T. (2015). Differential effects of a long teacher training internship on students' learning-to-teach patterns. *European Journal of Teacher Education, 38*(4), 484-495.
- Dunn, T. G., & Shriener, C. (1999). Deliberate practice in teaching: What teachers do for self-improvement. *Teaching and Teacher Education, 15*(6), 631-651.
- Edwards, A. (2005). Relational agency: Learning to be a resourceful practitioner. *International Journal of Educational Research, 43*(3), 168-182.
- Edwards, A., & D'arcy, C. (2004). Relational agency and disposition in sociocultural accounts of learning to teach. *Educational Review, 56*(2), 147-155.

- Edwards, A., & Protheroe, L. (2003). Learning to see in classrooms: What are student teachers learning about teaching and learning while learning to teach in schools? *British Educational Research Journal*, 29(2), 227-242.
- Edwards, A. (2007). Relational Agency in Professional Practice: A CHAT Analysis. *An International Journal of Human Activity Theory*, 1, 1-17.
- Emirbayer, M., & Mische, A. (1998). What is agency? *American Journal of Sociology*, 103(4), 962-1023.
- Endedijk, M. D., Vermunt, J. D., Meijer, P. C., & Brekelmans, M. (2014). Students' development in self-regulated learning in postgraduate professional education: A longitudinal study. *Studies in Higher Education*, 39(7), 1116-1138.
- Eraut, M. (1995). Schon Shock: a case for refraining reflection-in-action? *Teachers and Teaching*, 1(1), 9-22.
- Eraut, M. (2007). Learning from other people in the workplace. *Oxford Review of Education*, 33(4), 403-422.
- Eteläpelto, A., Vähäsantanen, K., Hökkä, P., & Paloniemi, S. (2013). What is agency? Conceptualizing professional agency at work. *Educational Research Review*, 10, 45-65.
- Evers, W. J., Brouwers, A., & Tomic, W. (2002). Burnout and self-efficacy: A study on teachers' beliefs when implementing an innovative educational system in the Netherlands. *British Journal of Educational Psychology*, 72(2), 227-243.
- Feiman-Nemser, S., & Buchmann, M. (1986). The first year of teacher preparation: Transition to pedagogical thinking? *Journal of Curriculum Studies*, 18(3), 239-256.

- Fuller, F., & Bown, O. (1975). Becoming a teacher. In K. Ryan (Ed), Seventy-fourth year book of the National Society for the Study of Education: Pt. 2. Teacher education. University of Chicago.
- Gratch, A. (2001). The culture of teaching and beginning teacher development. *Teacher Education Quarterly*, 28(4), 121-136.
- Greeno, J. G. (2006). Authoritative, accountable positioning and connected, general knowing: Progressive themes in understanding transfer. *The Journal of the Learning Sciences*, 15(4), 537-547.
- Grosemans, I., Boon, A., Verclairen, C., Dochy, F., & Kyndt, E. (2015). Informal learning of primary school teachers: Considering the role of teaching experience and school culture. *Teaching and Teacher Education*, 47, 151–161.
- Hagger, H., Burn, K., Mutton, T., & Brindley, S. (2008). Practice makes perfect? learning to learn as a teacher. *Oxford Review of Education*, 34(2), 159-178.
- Hagger, H., & McIntyre, D. (2006). *Learning teaching from teachers: Realising the potential of school-based teacher education*. McGraw-Hill Education (UK).
- Hair, J. F., Black, W. C., Babin, B. J., & Anderson, R. E. (2014). *Multivariate Data Analysis – Pearson New International Edition*. Harlow: Pearson Education.
- Hakkarainen, K., Paavola, S., & Lipponen, L. (2004). From communities of practice to innovative learning communities. *Life Long Learning in Europe*, 6(2), 74-84.
- Hashweh, M. Z. (1987). Effects of subject-matter knowledge in the teaching of biology and physics. *Teaching and Teacher Education*, 3(2), 109-120.

- Heikonen, L., Pietarinen, J., Pyhältö, K., Toom, A., & Soini, T. (2017). Early career teachers' sense of professional agency in the classroom: associations with turnover intentions and perceived inadequacy in teacher–student interaction. *Asia-Pacific Journal of Teacher Education, 45*(3), 250-266.
- Heikonen, L., Toom, A., Pyhältö, K., Pietarinen, J., & Soini, T. (2017). Student-teachers' strategies in classroom interaction in the context of the teaching practicum. *Journal of Education for Teaching, 43*(5), 534-549.
- Hoekstra, A., Brekelmans, M., Beijaard, D., & Korthagen, F. (2009). Experienced teachers' informal learning: Learning activities and changes in behavior and cognition. *Teaching and Teacher Education, 25*(5), 663-673.
- Hu, L. T., & Bentler, P. M. (1999). Cutoff criteria for fit indexes in covariance structure analysis: Conventional criteria versus new alternatives. *Structural Equation Modeling: a Multidisciplinary Journal, 6*(1), 1-55.
- Jakku-Sihvonen, R., & Niemi, H. (2006). The Bologna process and its implementation in teacher education. In R. Jakku-Sihvonen & H. Niemi (Eds.), *Research-based Teacher education in Finland - Reflections by Finnish teacher educators* (pp. 17-29). (Research in Educational Sciences 25.) Helsinki: Finnish Educational Research Association.
- Jennings, P. A., & Greenberg, M. T. (2009). The prosocial classroom: Teacher social and emotional competence in relation to student and classroom outcomes. *Review of Educational Research, 79*(1), 491-525.

- Jenset, I. S., Klette, K., & Hammerness, K. (2017). Grounding teacher education in practice around the world: An examination of teacher education coursework in teacher education programs in Finland, Norway, and the United States. *Journal of Teacher Education*.
- Jyrhämä R., Syrjäläinen E. (2011). “Good pal, wise dad and nagging wife” – And other views of teaching practice mentors. In A. Lauriala, R. Rajala, H. Ruokamo & O. Ylitapio-Mäntylä (Eds.), *Navigating in Educational Contexts* (pp. 137-149). Rotterdam: Sense Publishers.
- Järvelä, S. (1998). Socioemotional aspects of students' learning in a cognitive-apprenticeship environment. *Instructional science*, 26(6), 439-472.
- Kazemi, E., Ghouseini, H., Cunard, A., & Turrou, A. C. (2016). Getting inside rehearsals: Insights from teacher educators to support work on complex practice. *Journal of Teacher Education*, 67(1), 18-31.
- Klassen, R. M., & Chiu, M. M. (2011). The occupational commitment and intention to quit of practicing and pre-service teachers: Influence of self-efficacy, job stress, and teaching context. *Contemporary Educational Psychology*, 36(2), 114-129.
- Korthagen, F., Loughran, J., & Russell, T. (2006). Developing fundamental principles for teacher education programs and practices. *Teaching and Teacher Education*, 22(8), 1020-1041.
- Korthagen, F. A. (2010). Situated learning theory and the pedagogy of teacher education: Towards an integrative view of teacher behavior and teacher learning. *Teaching and Teacher Education*, 26(1), 98-106.

- Korthagen, F. (2017). Inconvenient truths about teacher learning: towards professional development 3.0. *Teachers and Teaching: Theory and Practice*, 23(4), 387-405.
- Kunter, M., Klusmann, U., Baumert, J., Richter, D., Voss, T., & Hachfeld, A. (2013). Professional competence of teachers: Effects on instructional quality and student development. *Journal of Educational Psychology*, 105(3), 805-820.
- Kyndt, E., Gijbels, D., Grosemans, I., & Donche, V. (2016). Teachers' everyday professional development: mapping informal learning activities, antecedents, and learning outcomes. *Review of Educational Research*, 86(4), 1111-1150.
- Kwakman, K. (2003). Factors affecting teachers' participation in professional learning activities. *Teaching and Teacher Education*, 19(2), 149-170.
- Lasky, S. (2005). A sociocultural approach to understanding teacher identity, agency and professional vulnerability in a context of secondary school reform. *Teaching and teacher education*, 21(8), 899-916.
- Leeferink, H., Koopman, M., Beijaard, D., & Ketelaar, E. (2015). Unraveling the complexity of student teachers' learning in and from the workplace. *Journal of Teacher Education*, 66(4), 334-348.
- Lieberman, A., & Pointer Mace, D. H. (2009). The role of 'accomplished teachers' in professional learning communities: uncovering practice and enabling leadership. *Teachers and Teaching: Theory and Practice*, 15(4), 459-470.
- Lipponen, L., & Kumpulainen, K. (2011). Acting as accountable authors: Creating interactional spaces for agency work in teacher education. *Teaching and Teacher Education*, 27(5), 812-819.

- Lohman, M. C., & Woolf, N. H. (2001). Self-initiated learning activities of experienced public school teachers: Methods, sources, and relevant organizational influences. *Teachers and Teaching: Theory and Practice*, 7(1), 59-74.
- Lohman, M. C. (2006). Factors influencing teachers' engagement in informal learning activities. *Journal of Workplace Learning*, 18(3), 141-156.
- Lortie, D. (1975). School teacher: A sociological perspective. *University of Chicago*.
- Lunenberg, M., Korthagen, F., & Swennen, A. (2007). The teacher educator as a role model. *Teaching and Teacher Education*, 23(5), 586-601.
- Mainhard, M. T., Brekelmans, M., den Brok, P., & Wubbels, T. (2011). The development of the classroom social climate during the first months of the school year. *Contemporary educational psychology*, 36(3), 190-200.
- Martin, A. J., & Dowson, M. (2009). Interpersonal relationships, motivation, engagement, and achievement: Yields for theory, current issues, and educational practice. *Review of Educational Research*, 79(1), 327-365.
- McDonald, M. A., Kazemi, E., & Kavanagh, S. S. (2013). Core practices and pedagogies of teacher education: A call for a common language and collective activity. *Journal of Teacher Education*, 64(5), 378-386.
- Meirink, J. A., Meijer, P. C., Verloop, N., & Bergen, T. C. (2009). How do teachers learn in the workplace? An examination of teacher learning activities. *European Journal of Teacher Education*, 32(3), 209-224.

- Mena, J., Hennissen, P., & Loughran, J. (2017). Developing pre-service teachers' professional knowledge of teaching: The influence of mentoring. *Teaching and Teacher Education*, 66, 47-59.
- Ministry of Justice (986/1998). *Asetus opetustoimen henkilöstön kelpoisuusvaatimuksista [Teaching Qualifications Decree]*. Retrieved May 13, 2019, from <https://www.finlex.fi/fi/laki/ajantasa/1998/19980986>
- Ministry of Justice (794/2004). *Government decree on university degrees*. Retrieved May 13, 2019, from <https://www.finlex.fi/en/laki/kaannokset/2004/en20040794>
- Muthén, L. K., & Muthén, B. O. (1998–2012). *Mplus user's guide* (7th ed.). Los Angeles, CA: Muthén & Muthén.
- Naidoo, K., & Kirch, S. A. (2016). Candidates use a new teacher development process, transformative reflection, to identify and address teaching and learning problems in their work with children. *Journal of Teacher Education*, 67(5), 379-391.
- Ng, W., Nicholas, H., & Williams, A. (2010). School experience influences on pre-service teachers' evolving beliefs about effective teaching. *Teaching and Teacher Education*, 26(2), 278-289.
- Niemi, H. (2016). The societal factors contributing to education and schooling in Finland. In *Miracle of education - The principles and practices of teaching and learning in Finnish schools*. Leiden, the Netherlands: Brill/Sense.
- Niemi, H., Nevgi, A., & Aksit, F. (2016). Active learning promoting student teachers' professional competences in Finland and Turkey. *European Journal of Teacher Education*, 39(4), 471-490.

- Pantić, N. (2015). A model for study of teacher agency for social justice. *Teachers and Teaching, 21*(6), 759-778.
- Pfitzner-Eden, F. (2016). I feel less confident so I quit? Do true changes in teacher self-efficacy predict changes in preservice teachers' intention to quit their teaching degree? *Teaching and Teacher Education, 55*, 240-254.
- Pietarinen, J., Pyhältö, K., & Soini, T. (2016). Teacher's professional agency—a relational approach to teacher learning. *Learning: Research and Practice, 2*(2), 112-129.
- Pietarinen, J., Pyhältö, K., Soini, T., & Salmela-Aro, K. (2013). Reducing teacher burnout: A socio-contextual approach. *Teaching and Teacher Education, 35*, 62-72.
- Postareff, L., Lindblom-Ylänne, S., & Nevgi, A. (2007). The effect of pedagogical training on teaching in higher education. *Teaching and Teacher Education, 23*(5), 557-571.
- Pyhältö, K., Pietarinen, J., Haverinen, K., Toom, A., Beijaard, D., & Soini, T. (submitted). Trajectories of Subject Teacher Students' Professional Agency in the Classroom.
- Pyhältö, K., Pietarinen, J., & Soini, T. (2012). Do comprehensive school teachers perceive themselves as active professional agents in school reforms? *Journal of Educational Change, 13*(1), 95-116.
- Pyhältö, K., Pietarinen, J., & Soini, T. (2014). Comprehensive school teachers' professional agency in large-scale educational change. *Journal of Educational Change, 15*(3), 303-325.

- Pyhältö, K., Pietarinen, J., & Soini, T. (2015). Teachers' professional agency and learning – from adaption to active modification in the teacher community. *Teachers and Teaching: Theory and Practice*, 21(7), 811-830.
- Rajuan, M., Beijaard, D., & Verloop, N. (2008). Student teachers' perceptions of their mentors as internal triggers for learning. *Teaching Education*, 19(4), 279-292.
- Richter, D., Kunter, M., Klusmann, U., Lüdtke, O., & Baumert, J. (2011). Professional development across the teaching career: Teachers' uptake of formal and informal learning opportunities. *Teaching and Teacher Education*, 27(1), 116-126.
- Rigelman, N. M., & Ruben, B. (2012). Creating foundations for collaboration in schools: Utilizing professional learning communities to support teacher candidate learning and visions of teaching. *Teaching and Teacher Education*, 28(7), 979-989.
- Roberts, J., & Graham, S. (2008). Agency and conformity in school-based teacher training. *Teaching and Teacher Education*, 24(6), 1401-1412.
- Rogoff, B., Matusov, E., & White, C. (1996). Models of teaching and learning: Participation in a community of learners. *The Handbook of Education and Human Development*, , 388-414.
- Rots, I., Kelchtermans, G., & Aelterman, A. (2012). Learning (not) to become a teacher: A qualitative analysis of the job entrance issue. *Teaching and Teacher Education*, 28(1), 1-10.
- Saariaho, E., Pyhältö, K., Toom, A., Pietarinen, J., & Soini, T. (2016). Student teachers' self- and co-regulation of learning during teacher education. *Learning: Research and Practice*, 2(1), 44-63.

- Sachs, J. (2000). The activist professional. *Journal of Educational Change*, 1(1), 77-94.
- Salonen, P., Vauras, M., & Efklides, A. (2005). Social interaction-what can it tell us about metacognition and coregulation in learning? *European Psychologist*, 10(3), 199-208.
- Saloviita, T., & Tolvanen, A. (2017). Outcomes of primary teacher education in Finland: an exit survey. *Teaching Education*, 28(2), 211-225.
- Scales, R. Q., Wolsey, T. D., Lenski, S., Smetana, L., Yoder, K. K., Dobler, E., ... & Young, J. R. (2017). Are We Preparing or Training Teachers? Developing Professional Judgment in and Beyond Teacher Preparation Programs. *Journal of Teacher Education*.
- Schön, D. A. (1987). *Educating the reflective practitioner: Toward a new design for teaching and learning in the professions*. Jossey-Bass.
- Shaughnessy, M., & Boerst, T. A. (2017). Uncovering the Skills That Preservice Teachers Bring to Teacher Education: The Practice of Eliciting a Student's Thinking. *Journal of Teacher Education*.
- Sherin, M., Jacobs, V., & Philipp, R. (2011). *Mathematics Teacher Noticing: Seeing through Teachers' Eyes*. New York: Routledge.
- Smaller, H. (2005). Teacher informal learning and teacher knowledge: Theory, practice and policy. *International handbook of educational policy* (pp. 543-568) Springer.
- Soini, T., Pietarinen, J., Toom, A., & Pyhältö, K. (2015). What contributes to first-year student teachers' sense of professional agency in the classroom? *Teachers and Teaching: Theory and Practice*, 21(6), 641-659.

- Soini, T., Pyhältö, K., & Pietarinen, J. (2010). Pedagogical well-being: Reflecting learning and well-being in teachers' work. *Teachers and Teaching: Theory and Practice*, 16(6), 735-751.
- Spilt, J. L., Koomen, H. M. Y., & Thijs, J. T. (2011). Teacher wellbeing: The importance of teacher–student relationships. *Educational Psychology Review*, 23(4), 457-477.
- Stürmer, K., Seidel, T., & Holzberger, D. (2016). Intra-individual differences in developing professional vision: preservice teachers' changes in the course of an innovative teacher education program. *Instructional Science*, 44(3), 293-309.
- Tang, S. Y., Cheng, M. M., & Wong, A. K. (2016). The preparation of pre-service student teachers' competence to work in schools. *Journal of Education for Teaching*, 42(2), 149-162.
- Tilson, J., Sandretto, S., & Pratt, K. (2017). Connecting theory to practice: Using preservice teachers' beliefs, theories and video-recorded teaching to prompt a cycle of praxis. *Teaching and Teacher Education*, 67, 454-463.
- Toom, A., Husu, J., & Patrikainen, S. (2015). Student teachers' patterns of reflection in the context of teaching practice. *European Journal of Teacher Education*, 38(3), 320-340.
- Toom, A., Kynäslähti, H., Krokfors, L., Jyrhämä, R., Byman, R., Stenberg, K., ... & Kansanen, P. (2010). Experiences of a Research-based approach to teacher education: Suggestions for future policies. *European Journal of Education*, 45(2), 331-344.
- Toom, A., Pietarinen, J., Soini, T., & Pyhältö, K. (2017). How does the learning environment in teacher education cultivate first year student teachers' sense of professional agency in the professional community? *Teaching and Teacher Education*, 63, 126-136.

- Turnbull, M. (2005). Student teacher professional agency in the practicum. *Asia-Pacific Journal of Teacher Education*, 33(2), 195-208.
- Turnbull, M. D. (2002). Student teacher professional agency in the practicum: Myth or possibility? Curtin University of Technology.
- VAKAVA. (2017). VAKAVAan osallistuneiden koulutusten hakemusmäärät ja pisterajat 2017. https://www.helsinki.fi/sites/default/files/atoms/files/hakijamaarat_2017.pdf
- Van Eekelen, I., Boshuizen, H., & Vermunt, J. (2005). Self-regulation in higher education teacher learning. *Higher Education*, 50(3), 447-471.
- Van Eekelen, I., Vermunt, J., & Boshuizen, H. (2006). Exploring teachers' will to learn. *Teaching and Teacher Education*, 22(4), 408-423.
- van Velzen, C., Volman, M., Brekelmans, M., & White, S. (2012). Guided work-based learning: Sharing practical teaching knowledge with student teachers. *Teaching and Teacher Education*, 28(2), 229-239.
- Veenman, S. (1984). Perceived problems of beginning teachers. *Review of educational research*, 54(2), 143-178.
- Väisänen, S., Pietarinen, J., Pyhältö, K., Toom, A., & Soini, T. (2017). Social support as a contributor to student teachers' experienced well-being. *Research Papers in Education*, 32(1), 41-55.
- Wheatley, K. F. (2005). The case for reconceptualizing teacher efficacy research. *Teaching and Teacher Education*, 21(7), 747-766.

Appendix 1

Scales*	Cronbach's α		
	T1	T2	T3
<hr/>			
Student teacher's professional agency in the classroom			
Reflection in classroom (REF)	.69	.67	.68
Ref1: In my work it is important to develop as a facilitator of pupils' overall growth.			
Ref2: I'd like to understand young people's ways of thinking and acting better.			
Ref3: I think we can all learn something in a teaching situation.			
Ref4: I can learn from my failures.			
Ref5: I regularly endeavour to estimate my success in teaching situations.			
Modeling (MOD)	.79	.89	.85
Mod1: I learn innovative teaching methods by observing them in different teaching situations.			
Mod2: I learn functional teaching methods by observing experienced teachers' teaching.			
Collaborative learning environment (CLE)	.84	.85	.82
Cle1: I'm able to create a nice atmosphere together with my students.			
Cle2: I'm able to find teaching methods to engage even the most challenging groups of pupils.			
Cle3: I'm able to find ways to support the learning processes of all my pupils.			
Cle4: I am satisfied with my present pedagogical practices.			
Cle5: I've been able to build functioning interactive relationships with my pupils.			
Cle6: I can modify my teaching to adjust to different groups of pupils.			
Cle7: I feel more and more successful in my teaching.			
Cle8: I am able to utilise pupils' feedback when planning my teaching.			
Competence (COM)	.87	.82	.80
Com11: I am able to support the construction of pupils' understanding in my teaching.			
Com12: I am able to utilise different teaching methods according to various contents of teaching.			
Com13: I am able to evaluate the suitability of different teaching methods to different subject contents.			
Com14: I can develop new pedagogical practices in my teaching.			
Com15: I can analyse my professional practice as a whole.			

*The item scale: completely disagree 1 2 3 4 5 6 completely agree 7.