



Finnish energy renovation subsidies in multifamily apartment buildings: Lessons learnt and best practices

Hatef Hajian^{a,*}, Petri Pylsy^{a,b}, Raimo Simson^{a,c}, Kaiser Ahmed^{a,d}, Paula Sankelo^e, Alo Mikola^{a,c}, Jarek Kurnitski^{a,c}

^a Department of Civil Engineering, School of Engineering, Aalto University, 02150 Espoo, Finland

^b The Finnish Real Estate Federation, 00100 Helsinki, Finland

^c Department of Civil Engineering and Architecture, NZEB Research Group, Tallinn University of Technology, 19086 Tallinn, Estonia

^d Granlund Consulting Oy, 00701 Helsinki, Finland

^e Finnish Environment Institute, 00790 Helsinki, Finland

ARTICLE INFO

Keywords:

Energy renovation
Energy Performance Certificate
Deep renovation
ARA renovation subsidies

ABSTRACT

This study analysed renovation measures implemented with ARA renovation subsidy in Finland in multifamily apartment buildings. Measured energy data was used to calibrate the energy simulation model of the most typical renovated building from the 1970 s. For the reference building, a comprehensive set of renovation packages were applied to assess the performance of ARA grants. It was noticed that official energy performance certificates (EPC) overestimated before the renovation energy use as well as energy saving by a factor of almost 2. It was notable that in calculated EPCs, after renovation, EP-value was higher than before renovation, EP-value based on measured energy use. The main reasons for faulty energy calculations were strong overestimations in the building leakage rate and ventilation airflow rate. Renovation packages reduced EP-value by 8 % to 27 %, including lighting and appliances. Those using district heat resulted in a small increase in electricity with a flat duration curve, but the combined ground source and exhaust air heat pump showed the highest peak electricity power increase by factor 6. Exhaust air heat pump, window replacement and photovoltaic were the most cost-effective options, while packages with additional insulation faced considerably higher costs than the sum of ARA support and monthly savings could cover bank loans; thus, ARA support was clearly too small to support deep renovation. The need to improve the accuracy of EPCs in assessing energy performance to facilitate more effective financial support was a finding that can be important for any support scheme to secure the necessary funding for renovation.

1. Introduction

1.1. The EU building energy renovation policies

Buildings account for 40 % of the EU's overall energy use and 36 % of its energy-related greenhouse gas emissions [1]. According to the Europe Renovation Wave, 85 % of the existing building stock in the EU was constructed before 2001, and 85–95 % of these structures will still be operating in 2050 [1]. While just 1 % of buildings currently undergo

renovations, only 0.2 % are renovated deeply annually, resulting in at least a 60 % reduction in energy usage [1]. The European Commission categorised the renovation depths as 1. Light renovation (<30 % primary energy use), 2. Medium renovation (30–60 % primary energy use), and 3. Deep renovation (>60 % primary energy use) [2]. Deep renovation projects have the potential to reduce greenhouse gas emissions and energy consumption dramatically and increase the utilisation of renewable resources [3]. The energy renovation of residential buildings in hot and temperate Mediterranean zones of the EU can result in almost

Abbreviations: ARA, Finnish acronym for The Housing Finance and Development Centre of Finland; AWHP, Air-to-water heat pump; BPIE, Buildings Performance Institute Europe; EAHP, Exhaust air heat pump; EPBD, Energy Performance of Buildings Directive; GSHP, Ground-source heat pump; LTRS, Long-Term renovation strategy; NECP, National Energy and Climate Plan.

* Corresponding author.

E-mail addresses: hatef.hajian@aalto.fi (H. Hajian), petri.pylsy@kiinteistoliitto.fi (P. Pylsy), raimo.simson@aalto.fi (R. Simson), kaiser.ahmed@aalto.fi (K. Ahmed), paula.sankelo@syke.fi (P. Sankelo), alo.mikola@aalto.fi (A. Mikola).

<https://doi.org/10.1016/j.enbuild.2024.113986>

Received 1 November 2023; Received in revised form 26 January 2024; Accepted 2 February 2024

Available online 5 February 2024

0378-7788/© 2024 The Author(s). Published by Elsevier B.V. This is an open access article under the CC BY license (<http://creativecommons.org/licenses/by/4.0/>).

zero-energy buildings, with the correct insulation thicknesses being a critical element [4]. In the EU's cold climate regions like Finland, heating energy is dominating, and achieving nearly zero-energy buildings need more measures [5–7]. Energy consumption can be greatly reduced, and indoor temperature conditions can be enhanced by using optimum thermal insulation, enhanced energy-efficient windows and doors, and balanced ventilation with heat recovery systems [5,8]. In these regions, renovating external walls and building facades with energy-efficient systems that are multifunctional is a key approach to energy-efficient renovation [7]. Nevertheless, there are important issues that must be resolved, such as the delayed heating transition due to a fragmented market, the requirement for greater supply-side coordination, and the need for customers to have their renovation processes simplified [9].

The Member States' integrated National Energy and Climate Plans (NECPs) to include promoting the decarbonisation of the current building stock by 2050 [2]. Moreover, The EU Commission proposed the EU Green Deal in 2019, intending to reach net zero emissions by 2050 and tighten the earlier 2030 reduction target from 40 % to 55 %, compared to 1990 levels [2]. The European Commission put up Fit for 55, a set of legislative measures in 2021 that would ensure that the 2030 target of a 55 % reduction in emissions was reachable [10]. The European Commission implores the EU Parliament and EU Member States to ponder further improvements for the Fit for 55 packages presently being negotiated, and several of these suggested changes are specifically relevant to the construction industry [11]. Therefore, as part of the Fit for 55 packages, the European Commission has proposed a revised Energy Performance of Buildings Directive (EPBD) [12]. These objectives are currently part of the European Climate Law, which became effective in 2021 [2]. EPBD mandated that all Member States develop a Long-Term Renovation Strategy (LTRS) in 2018 [2]. Furthermore, the European Commission revised the EPBD in 2023, aiming to reduce the average primary energy use of residential buildings by 16 % by 2030 and 20–22 % by 2035 [13]. Also from the climate change perspective, building energy renovations must proceed quickly [14]. The primary concern is that if the planet's ongoing heating pushes Earth systems (ocean currents, ice sheets, rainforests, and permafrost) above their supposedly tipping thresholds, this is expected to trigger a sequence of rapid changes and could cause the climate to warm much more quickly [15,16].

1.2. Long-Term renovation strategies (LTRS)

Renovations that save energy can have numerous positive outcomes and lower emissions. In the best scenarios, renovation can reduce emissions and energy costs, enhance indoor comfort, raise property values, generate green jobs, and increase state tax revenue. Numerous studies have looked into the additional benefits of energy renovations for residential apartment buildings [17–19]. According to Rose et al., the achieved co-benefits, including a better indoor environment, are frequently the most appreciated renovation results for apartment occupants [18]. In fact, it would appear that energy saving is a “side effect” or a “co-benefit” from a generally advantageous building renovation project if all the co-benefits were systematically examined [18].

According to the EPBD 2018 recast, the national Long-Term Renovation Strategies were to be submitted by 10.3.2020 [20]. By analysing 14 LTRs, Staniaszek et al. (2020) concluded that only Spain's strategy fully complies with the EPBD standards [21]. Finland was one of the member states that submitted its LTRs within the deadline [22]. The Commission and BPIE gave the Finnish LTRs favourable evaluations; in the BPIE comparison, Finland and Belgium-Flanders tied for the second position after Spain [21]. Finland was called out for providing a thorough decarbonisation roadmap, a clear building stock assessment [15,23] and precise progress criteria [24]. According to Staniaszek et al. (2020), BPIE observes that the Finnish strategy only gives initiatives encouraging affordable deep renovations a very cursory look [21].

The Finnish LTRs claims that the most profitable times to renovate residential apartment buildings are when other renovations or repairs are planned [22]. Installing an exhaust air heat pump (EAHP), replacing outdated windows, balancing the heating system, and adding own solar PV capacity are among the found cost-optimal remodelling measures for a district-heated residential apartment building [22]. The building envelope can be made more energy-efficient by adding thermal insulation, but only if repairs are already planned [22]. As both the European Commission and BPIE have emphasised, the Finnish LTRs does not reflect the energy savings feasible with the planned renovation actions.

A renovation that increases a building's energy efficiency by less than 30 % is considered a light renovation by the European Commission [2]. Since the Finnish LTRs is criticised for not supporting extensive renovations (energy savings > 60 %), it appears that even medium renovations (energy savings 30–60 %) may not be profitable in the perspective of the Finnish LTRs. However, as the Finnish LTRs also used other sources for cost-optimization purposes, it is impossible to draw a firm conclusion from this.

It's possible that the cost-effective renovation measures outlined in the Finnish LTRs will lead to light or medium renovations, but it appears doubtful that they would result in deep energy renovations. Specifically, converting the district heating into a ground-source heat pump is not particularly stated as one of the cost-effective renovation measures. This stands in direct contrast to numerous recent studies from Finland, where it was determined that replacing district heating with a GSHP system was the most affordable option for older residential apartment buildings. In fact, the LTRs is primarily focused on this older building stock. Nevertheless, Finland's LTRs indicators and interim target settings implicitly take into account the growing shift away from district heating and toward heat pump systems. As a result, the renovations that could be truly “deep”—reducing energy demand by greater than 60 %—are included in the Finnish LTRs, albeit in a less explicit manner and with less importance.

1.3. Cost-optimal energy renovations in Finland

Using precast concrete panels, Niemelä et al. (2017) created a model of a Finnish residential apartment structure typical of the late 1960 s to mid-1970 s [25]. The authors determined the most cost-effective renovation strategies for these apartment buildings from the perspectives of both main energy use and CO₂ emissions in a simulation-based multi-objective optimisation study as switching from district heating to a ground source heat pump system [25]. In terms of cost-effectiveness, the performance of the Exhaust Air Heat Pump (EAHP) and the Air-to-Water Heat Pump (AWHP) systems was comparable to that of the GSHP system [25]. A heat pump system conversion, solar PV installation, and window replacements were all part of the renovation package that was most cost-optimal. However, adding thermal insulation to the building envelope did not seem to be a cost-effective solution [25]. Comparable findings have been made for Finnish brick apartment buildings from the 1960 s, which predate the concrete panel apartment structures [26].

Hirvonen et al. (2018) conducted simulation-based optimisation studies for a number of age cohorts of Finnish residential apartment buildings [27]. They come to the conclusion that using heat pumps is the most cost-effective option to cut emissions. Again, GSHP was the most cost-optimal option, but EAHP may also significantly reduce emissions while remaining economically viable [27]. The optimal renovation packages also included solar thermal and solar PV, heat recovery from sewage water, new windows, and heat pumps [27]. It may be cost-effective to add additional insulation to the building envelope of the older apartment buildings, those constructed before 1976 [27].

Hirvonen et al. (2018) analysis demonstrated that significant emissions reductions could be achieved even in a cost-neutral manner when the 25-year calculation time is taken into account [16]. In pre-1976 buildings that were still connected to the district heating network, emissions would be a 28 % reduction in emissions at no additional

expense [27]. Much greater emission reductions would be possible if the building switched to a heat pump system, including 68 % with an exhaust air heat pump system and 80 % with a ground source heat pump [27].

Old residential apartment buildings can be renovated deeply and cost-effectively, but this approach has certain drawbacks. According to research by Hirvonen et al. (2019), switching from district heating to ground source heat pumps results in lower energy demand and CO₂ emissions but higher peak power demand [28]. They came to the conclusion that switching from district heating to a GSHP system could result in an hourly peak power demand increase of 46 to 153 % [28]. This is especially noticeable in January, the coldest winter month, when solar energy cannot help reduce the increased demand for electricity [28].

When taking into account the overall building stock, even if heat pump systems take the place of conventional heating systems, peak electricity demand might not necessarily rise since in many detached houses, due to the transition from direct electric heating to heat pump systems, it is anticipated that energy renovations will not increase the total peak power demand [29]. According to research by Hirvonen et al. (2021) that involved modelling a sizable section of the building stock and numerous different building types, deep energy renovations can help reduce peak power demand and energy demand of the building stock [30]. Additionally, they evaluated the total emission savings from energy improvements and concluded that frontloading emission reduction efforts were the best course of action [30]. Deep renovations can significantly impact cumulative carbon reductions when done early, contributing to achieving the climate targets [30]. From this aspect, it is really debatable whether it is a sensible general policy to carry out energy renovations only when other significant renovations are planned. Delaying energy renovation by 10–20 years means missing out on the chance to reduce emissions quickly.

More than the type, age, and condition of the building, there are other variables that affect how cost-effective renovations can be [31]. Important aspects to consider include typical refurbishment prices, energy expenses, area climate, and emission issues in ambient energy grids, which make comparing disparate countries and regions challenging [31]. Similar findings, such as prioritising heating system renovations above structural energy efficiency improvements, have been observed for residential apartment buildings, for example, in Switzerland [31]. Therefore, the optimal renovation packages may range significantly in regions with differing climates, energy mixes, price structures, or typical building problems. This demands additional research on the most typical buildings in various regions to identify the most effective energy-saving measures and renovation packages.

1.4. Energy renovation subsidies in Finland

In December 2019, the Finnish government passed a decree on energy renovation subsidies directed mainly at private building owners and housing associations. For residential apartment buildings, energy efficiency must be improved by 20 % more than the building code requires. This translates to an energy efficiency improvement of 32 % or more when compared with the original Energy Performance value “EP-value” (primary energy) of the building. Apartment buildings fulfilling this criterion can receive up to 4000 €/apartment for the approved renovation actions. If the building energy efficiency is improved to the regulation level of a new building, the subsidy is up to 6000 €/apartment. ARA, The Housing Finance and Development Centre of Finland, award the subsidies.

According to the ARA grant regulation, improving the EP-value of a building by 32 % is enough to receive subsidies. However, this energy efficiency improvement is placed in the medium renovation wave levels, which is not ambitious enough. It is important to demonstrate that it is possible to renovate more deeply by combining renovation measures to identify the optimum renovation packages that result in a reduction

closer to 60 % in the EP-value.

1.5. Objectives and outline of the study

As a summary of previous chapters, the following research needs were identified:

- While even medium renovations (energy savings of 30–60 %) may not be profitable from the perspective of the Finnish LTRS, there is a need to find the right renovation measures which are effective and have wide replication potential.
- As explained in section 1.3, the optimal renovation package varies across regions characterised by distinct climates, energy mixes, and energy price structures. Hence, further research is essential to investigate the most common building types in diverse regions with the aim of identifying the most economically efficient renovation package.
- According to Finnish ARA grant guidelines, buildings are eligible for support based on the amount of energy savings they achieve in the renovation. This eligibility criterion relies on the energy performance certificate, more specifically on the calculated EP-value before and after renovation. Consequently, there is a need to evaluate the accuracy of energy performance certificate energy calculations and to find relevant improvement possibilities.
- Renovation subsidies and other funding schemes would be likely used for decades to boost renovation according to energy and climate targets. As these schemes may have remarkable impacts on implemented renovation measures and volumes, there is a need to understand impacts and outcomes further to develop both their conditions and energy prediction methods.

The main objective of the study was to determine the energy and economic efficiency of an extended set of renovation packages, including the ones most popular in ARA renovation subsidies, applied in typical Finnish residential buildings from 1970. The specific aims were to evaluate the correctness of the case study buildings’ EPCs and actual energy savings achieved that make it possible to assess the effectiveness of the ARA renovation grants in Finland.

Building renovation policies at the EU level, long-term renovation strategies, cost-optimal energy renovation, and associated subsidies in Finland were reviewed to show directions and drivers for renovation. ARA subsidy statistics and the distribution of renovated buildings were conducted to identify the most common renovation packages implemented. Subsequently, the data from the selected case study buildings and the details of the building model simulation, calibration, and validation process were delineated. Heat pump plant models were constructed to be capable for dynamic simulation of renovation packages with exhaust air, ground source, district heating and heat recovery ventilation configurations. In the results and analysis section, an evaluation of the proposed renovation packages was conducted with regard to delivered energy, EP-value, electricity peak power, PV generated and self-used electricity, and other relevant parameters. The findings were discussed in conjunction with the economic feasibility associated with each renovation package. Finally, in the conclusion section, a summary of the key findings was presented.

2. Methods

2.1. Building statistics and distribution

We use ARA renovation subsidy data up until May 2022 [32]; out of 2816 single-family houses and multifamily apartment buildings granted an acceptable subsidy decision, 644 were multifamily apartment buildings (23 %). The largest age groups among these residential apartment buildings were 217 units from the 1960 s (34 %) and 191 units from the 1970 s (30 %). The age distribution of the 644 residential

apartment buildings that obtained renovation subsidies between January 2020 and May 2022 is depicted in Fig. 1.

Table 1 summarises central statistics on apartment building renovations according to construction year from the 1950 s through the 1980 s. In the 1960 s, sandwich concrete elements were first used in buildings. Therefore, even though the number of buildings in 1960 is slightly greater than in the 1970 s, the structure of these two time periods is fairly comparable. Furthermore, since the U-vale building regulation was introduced in 1960, buildings from the 1960 s and 1970 s are grouped together. Table 1 (EP-value before, median) reveals a minor change between the 1960 s (337) and 1970 s (306). Therefore, we intended to depict a building representative of this group.

Table 2 outlines the most typical renovation measures on these buildings, excluding design expenses. In every case, design expenses were the most often subsidised renovation action that was included in every renovation subsidy. It should be noted that some categories used by ARA do not enable to understand which technical solutions were used explicitly. ‘Heat pump, heat recovery, solar energy’ may apply for any type of heat pump, but also for heat recovery ventilation and PV. ‘Heat recovery from exhaust air or water’ more clearly refers to exhaust air heat pumps, while wastewater heat recovery solutions were not used. When referring to these categories, we use in our renovation packages EAHP, GSHP + EAHP and HRV.

2.2. Case study buildings

Table 3 contains the parameters of five case study buildings. Buildings 1, 2, and 3, built in the 1970 s, represent the most typical renovation measures of the studied sample. The data for these buildings were taken from the EPCs, which include energy calculations before and after renovation. As there are no measured energy data in EPCs, two other similar buildings, 4 and 5, not belonging to the studied subsidy sample but having measured energy data, were selected to make it possible to calibrate the reference building simulation model. Their similarities in characteristics (Table 3) led to classifying them in the same category. There were minimal differences in buildings’ U-values before renovation. Building 1 was the only building where external wall additional insulation (100 mm) was applied in the renovation. Very high building leakage rates have been reported in EPC-s, which are unrealistic according to model calibration results. To assess building leakage, energy experts have used national guidance that suggests high values for old buildings. Moreover, the formula for new buildings was used in the infiltration airflow rate calculation, which assumes a balanced ventilation system. However, the ventilation system in buildings 1 to 3 was mechanical exhaust ventilation, effectively reducing exfiltration

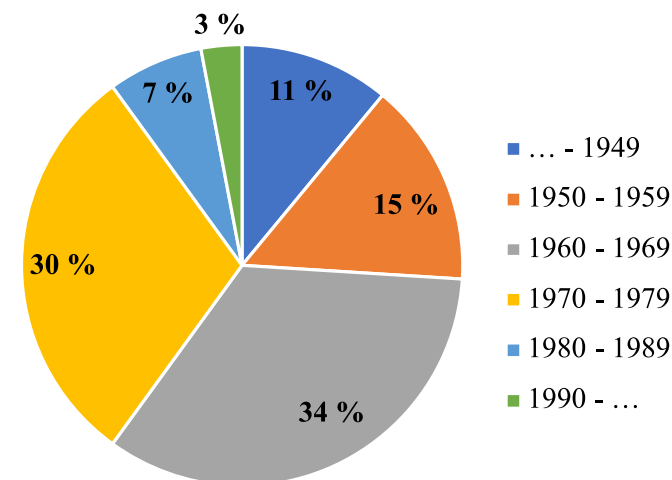

Fig. 1. The age distribution of the 644 multifamily apartment buildings that received renovation subsidies from January 2020 to May 2022.

Table 1 Statistics on subsidised residential apartment building renovations.

Renovations' statistics	Construction year			
	1950's	1960's	1970's	1980's
Buildings receiving subsidy	96	217	191	47
Apartments in total	3300	8493	7614	1426
Buildings with one subsidised action	6	11	9	0
Buildings with several subsidised actions	90	206	182	47
Actions done in total	242	597	568	136
Actions done in average	2.5	2.8	3	2.9
Total renovation cost (€), mean/median	358941/ 236002	512059/ 261500	540420/ 222498	391967/ 271700
Subsidy received (€), mean/median	77454/ 59237	94811/ 54171	95997/ 65535	78846/ 71075
EP-value before (kWh/m ² a), mean/median	316/364	331/337	291/306	213/181
EP-value after (kWh/m ² a), mean/median	169/170	148/143	144/143	123/119

Table 2 Five most common subsidised energy renovation actions for residential apartment buildings from the 1950's to 1980's, excluding the design expenses. The planning costs were the most common subsidised renovation action in all cases.

1950's	1960's	1970's	1980's
1. Heat pump, heat recovery, solar energy	1. Heat pump, heat recovery, solar energy	1. Heat pump, heat recovery, solar energy	1. Heat pump, heat recovery, solar energy
2. Energy control or building automation	2. Window and door replacement	2. Energy control or building automation	2. Window and door replacement
3. Window and door replacement	3. Energy control or building automation	3. Window and door replacement	3. Energy control or building automation
4. Oil boiler replacement	4. Heat recovery from exhaust air or water	4. Water saving measures	4. Heat recovery from exhaust air or water
5. Heat recovery from exhaust air or water	5. External wall insulation	5. Heat recovery from exhaust air or water	5. Improving air tightness

because of the negative pressure.







We aimed for the reference building model's specifications to resemble a 1970 s building, most typically renovated with subsidy. Therefore, we considered the median values that exist in real buildings from that time period. The proposed renovation measures were implemented in the reference building model developed and calibrated against building 5's measured data.

The renovation measures and cost breakdown for ARA subsidy buildings 1 to 3 are detailed in Table 4. All buildings used a combined exhaust air heat pump and ground source heat pump system where the heat is extracted from the brine loop through boreholes and the extract air heat exchanger. The water-saving taps and shower installation included in Building 2 a replacement of pipes and complete remodelling of bathrooms, which resulted in 654 €/m² cost from which only 24 €/m² is accounted as energy saving measure cost. In building 3, windows were renovated in 2016, and exterior doors on the ground level and in the basement were replaced in 2019, which explains the lower cost. The renovation grant received was 4000 € per apartment in building 1, but smaller in buildings 2 and 3 because of less eligible renovation works conducted.

2.3. Model calibration and construction of the reference building

To assess the energy savings of renovation measures, it is important to use a calibrated simulation model for realistic predictions. Therefore,

Table 3
The specifications of buildings.

Building specifications	Building 1		Building 2		Building 3		Building 4		Building 5		Reference building model
	Before renovation	After renovation	Before renovation	After renovation	Before renovation	After renovation	Before renovation	After renovation	Before renovation	After renovation	
External wall U-value, (W/m ² K)	0.51	0.21	0.41	0.48	0.34	0.34	0.41	0.48 ⁴	0.41	0.48 ⁴	0.48 ⁴
Floor U-value, (W/m ² K)	0.31		0.33	0.47	0.29	0.29	0.2	0.33 ⁴	0.2	0.33 ⁴	0.33 ⁴
Floor U-value, (W/m ² K)	0.34		0.44	0.47	0.29	0.29	0.3	0.44 ⁴	0.3	0.44 ⁴	0.44 ⁴
Windows U-value, (W/m ² K)	2.1	1	2.8	2.8	1.9	1 ⁶	1.40	2.10 ⁴	1.40	2.10 ⁴	2.10 ⁴
Exterior door U-value, (W/m ² K)	1.75		2.2	2.2	1.01	1.97	2.10	2.20 ⁵	2.10	2.20 ⁵	2.20 ⁵
System SFP value, (kW/(m ³ /s))	1.5	0.9	1.5	1.5	0.8	1.5	1.5	1.5 ⁴	1.5	1.5 ⁴	1.5 ⁴
Ventilation flow rate, (l/s m ²)	0.5 ¹		0.5 ¹	0.5 ¹	0.8	0.29	0.24 ²	0.24 ²	0.24 ²	0.24 ²	0.24 ²
Air leakage rate (q50), (m ³ /h m ²)	14.93 ³		14.71 ³	14.5 ³	4	4	2	2	2	2	2
Total net heated area, (m ²)	7976		4196	3182	4053	4053	3405	3405	3405	3405	3405
No. of apartments	96		50	47	52	52	46	46	46	46	46
Year of construction	1970		1974	1970	1981	1981	1963	1963	1963	1963	1963
Photo											

¹ Estimated value in EPCs. The real values may be lower.

² The ventilation flowrate varies between 0.2 l/s m² and 0.5 l/s m² depending on the outdoor temperature.

³ Unrealistically high values. Estimated based on the Finnish national guidelines.

⁴ Median value between buildings 1, 2, and 3 (before renovation) and buildings 4 and 5.

⁵ Windows are assumed as not to be replaced (Unrealistically high values reported for building 2 and 3).

⁶ EPC is calculated with U-value = 1.0, but the window replacement is not included in the budget and was not done.

Table 4
Renovation measures cost breakdown in the case study buildings.

Renovation measures	Building 1	Building 2	Building 3
Design, (€/m ²)	4.4	4.8	1.6
Combined EAHP and GSHP, (€/m ²)	66.3	88.1	97.4
Water-saving taps and showers, pressure reduction, (€/m ²)	30.5	654 ¹	25.3
Additional thermal insulation of the facade, (€/m ²)	357	-	-
Automation and temperature control equipment, (€/m ²)	-	7.4	-
Windows/exterior doors replacement, (€/m ²)	50.2	-	11.5 ²
Total energy-related cost, (€/m ²)	508	124	136
Renovation grant, (€/m ²)	48	27	29

¹ 24 €/m² as the energy-related cost was considered in the bathroom and toilet remodelling.

² Included only exterior door replacement.

the building 5 simulation model was calibrated against the measured data. After calibration, building envelope characteristics were slightly adjusted to represent buildings 1–3. The calibration of the model and the energy simulations were carried out using the IDA Indoor Climate and Energy (IDA ICE) [33] simulation tool. The calibrated simulation model, located in Helsinki, Finland, comprises 4 stories, including 46 apartments, 4 staircases, and 14 facility zones such as recycling room, laundry room, clubroom, etc. The total number of occupants is 87 persons. The overall heated area was 3405 m², and the window-wall ratio was 27.1 %. The heat transmittance coefficient (U-value) of the simulated building model elements is shown in Table 3.

The building leakage rate was estimated to be 4 m³/(h.m² ext. surf.) at a 50 Pa pressure difference based on the previous study [34]. Infiltration airflow was simulated with pressure coefficients of a semi-exposed environment according to the Air Infiltration and Ventilation Centre (AIVC) [35] and wind data from a nearby weather station at the Finnish Meteorological Institute [36]. Internal heat gain profiles (occupancy, appliances, and lighting) were specified based on ISO 17772-1:2017 [37]. The appliances' power was set to 4 W/m² according to the Finnish building code [38].

The airflow rate in building 5 was determined based on exhaust fan operation in normal and boost mode. Moreover, seasonal changes in the ventilation identified in the model calibration resulted in the ventilation airflow rate fluctuating between 0.2 l/s m² and 0.5 l/s m² annually. The hourly normal and boost airflow rate profiles (2a and 2b) and monthly fan power (2c) are illustrated in Fig. 2.

Measured data from district heating was utilised during the calibration and validation of the simulated model. To accurately simulate the fluctuations in domestic hot water (DHW), the DHW profile depicted in Fig. 3 was created using the method developed based on DHW consumption in Finnish apartment buildings by Ahmed et al. (2016). This method takes into account DHW consumption (l/person/day) and the number of occupants [39].

The model incorporated a SH system featuring 600 mm high water radiators (type 11) with a heat output of 1018 W/m at 70/40/21 °C, equipped with 2 K dead-band proportional thermostats. During the calibration process using on-site measured data, a 15 % oversizing assumption was applied to the radiators at the design outdoor air temperature of -26 °C.

The SH and DHW monthly measured and simulated data are shown in Table 5. The Root Mean Square Error (RMSE) of 3.88 indicates that the model was accurately calibrated against the measured data. Fig. 4 depicts the monthly total energy use (SH + DHW) of building 5.

From this calibrated model, the reference building model was constructed by replacing the median U-values of envelope elements for five case study buildings, changing the actual weather data to the TRY2020 weather file, and increasing the number of inhabitants. These

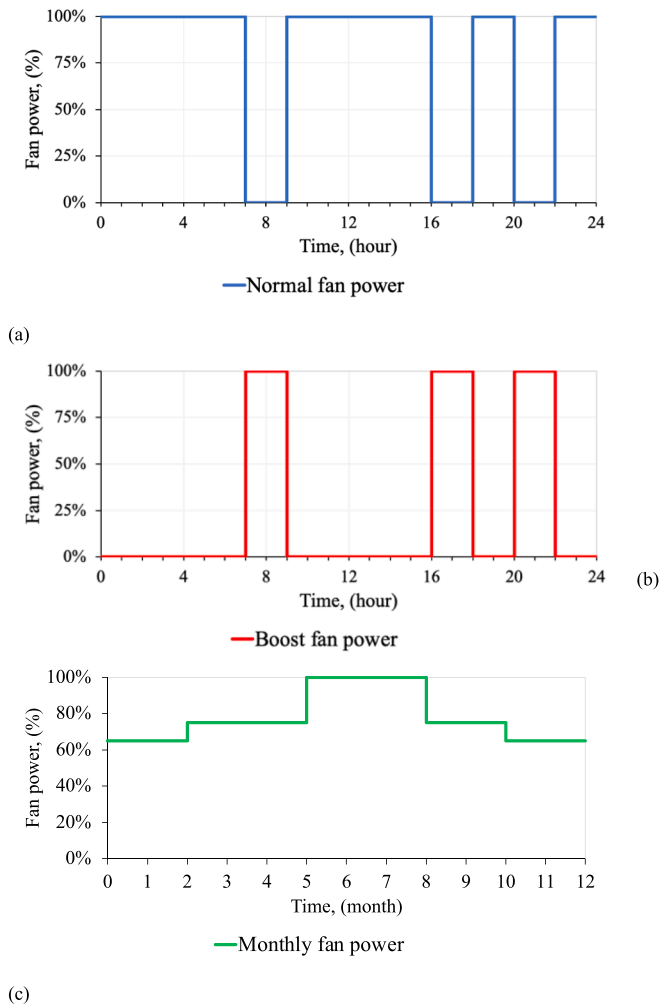

Fig. 2. Hourly normal and boost fan power (a and b) and monthly fan power (c) profiles in the reference building model.

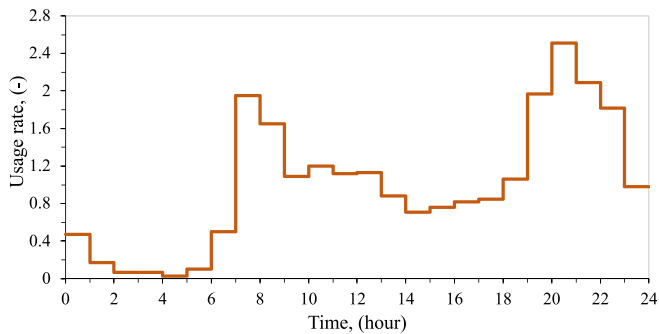

Fig. 3. The hourly DHW usage profile.

modifications were needed to represent a typical building from the 1970 s and slightly changed space heating, DHW and appliances, as seen in Table 6, where the energy consumption breakdown and EP-value for the five case study buildings and the reference building are summarised. Because in the renovation measures, the ventilation needs to be improved, the reference building with increased ventilation to 0.4 l/s m² is also reported in Table 6.

For buildings 1–3, Table 6 reports energy data from EPCs, and for buildings 4 and 5, measured energy data. After the model calibration, the official Finnish test reference year TRY2020 weather file has been

Table 5
Monthly measured and simulated data in SH and DHW of the calibrated model.

Month	SH energy, kWh/m ²		DHW energy, kWh/m ²	
	Measured	Simulated	Measured	Simulated
Jan	14.26	15.66	3.53	3.53
Feb	14.96	16.09	3.19	3.30
Mar	9.84	11.15	3.53	3.53
Apr	6.96	6.23	3.42	3.41
May	2.24	0.48	3.53	3.53
Jun	0.58	0.00	3.42	3.41
Jul	0.00	0.00	3.53	3.53
Aug	0.07	0.00	3.53	3.53
Sep	2.84	0.98	3.42	3.41
Oct	6.94	6.96	3.53	3.53
Nov	8.52	9.28	3.42	3.41
Dec	16.51	18.04	3.53	3.53
Total	83.72	84.86	41.62	41.64

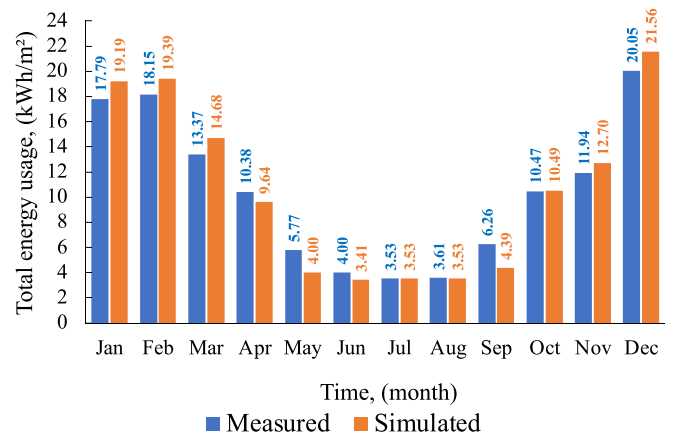

Fig. 4. The measured vs calibrated simulated total energy usage in building 4.

used for renovation measures simulation. To describe normal occupancy, we increased the number of occupants from 75 to 87 in the reference building since occupant density was lower than average with respect to the number of apartments in building 5 (46 apartments). Building 4, with 52 apartments and 104 residents, justifies building 5’s lower appliance and lighting electricity and DHW energy use. For the exhaust fan, the SFP value of 1.5 was used at the maximum airflow rate.

The DHW energy reported in Table 6 consists of DHW consumption and DHW distribution and circulation heat losses. The DHW distribution and circulation heat losses in buildings 1–3 EPCs have been estimated using Finnish guidelines for calculating energy consumption and heating power demand [40]. According to these, DHW needs 35 kWh/m² a, which may be reduced by 15 % in the case of a pressure reduction valve (after renovation situation). Considering the DHW distribution efficiency of 0.97, this results in 36.1 kWh/m² a. Taking into account the insulation thickness and possible towel driers in the DHW network; the DHW circulation heat losses energy is calculated as 70.1 kWh/m² a (40 W/m pipe loss x 0.2 m/m² pipe length x 8.76 = 70.1). Therefore, the total DHW consumption and DHW distribution and circulation heat losses result in old buildings 106.2 kWh/m² and, after dividing with a generation efficiency of 0.97 for district heating, results in 109.5 (building 1 value). Buildings 2 and 3 with higher values include towel driers. With improved pipe insulation, DHW circulation heat loss will be decreased to 17.5 kWh/m² a (10 x 0.2 x 8.76 = 17.5). Considering the existing towel driers in building 4, the overall DHW consumption and DHW distribution and circulation heat losses are calculated to be 53.6 kWh/m² a, which is close to the DHW consumption energy in building 4. The pressure reduction valve decreases the DHW need to 30.7 kWh/m² a (35 x 0.85/0.97 = 30.7), resulting in a total DHW consumption and DHW distribution and circulation heat loss of 48.2 kWh/m² a. The lower

Table 6
Energy consumption breakdown and EP-value in buildings.

Energy consumption and EP-value (Primary energy)	Building 1		Building 2		Building 3		Building 4	Building 5		Reference building	Reference building with code ventilation ²
	Before renovation	After renovation	Before renovation	After renovation	Before renovation	After renovation	Measured data	Before renovation			Simulated data
								Measured data	Simulated data	Simulated data	
Space heating, Heat, (kWh/m ² a)	181.34		171.96		189.51		74.36	83.71	84.02	77.49	80.99
Space heating, Heat pump electricity, (kWh/m ² a)		47.78		39.49		52.20					
DHW, Heat, (kWh/m ² a)	109.48		127.53		160.98		54.28	41.62	41.64	46.39	46.39
DHW, Heat pump electricity, (kWh/m ² a)		17.26		17.96		18.20					
Fans and pumps, (kWh/m ² a)	9.40	6.60	8.80	8.70	9.10	4.40	6.59	7.97	6.46	6.47	9.84
Appliances and lighting, (kWh/m ² a)	28.90		28.90		28.90		31.93	18.95	19.06	28.90	28.90
EP-value (primary energy)	191	121	195	114	396 ¹	124	111	95	93	104	110

¹Primary energy with coal boiler. In the case of district heating, primary energy would be 221.

²Ventilation airflow rate 0.4 l/s m² in the reference building.

occupancy rate (75) justifies the slightly lower value in building 5. In the reference building with adjusted occupancy (87), the simulated result is very close to this code value.

There are differences between the measured and simulated data for the fans and pumps in building 5 because measured facility electricity may include staircase lighting and other electricity. The EP- values were calculated with the primary energy factors of 0.5 and 1.2 for district heat and electricity, respectively. For instance, based on the before-renovation data, the EP- value in building 1 would be calculated as EP = (181.34 + 109.48) * 0.5 + (9.4 + 28.9) * 1.2 = 191.

In Table 6, the measured average ventilation flow rate for the reference building is 0.24 l/s m². In the EPCs of the first three buildings, however, the ventilation flow rate was considered to be the code value 0.5 l/s m². To obtain an appropriate reference model, we tried to implement the code ventilation rate of 0.5 l/s m² in the reference building. Nevertheless, the heating system capacity was not enough for such a high ventilation rate, and the indoor air temperature of the model's coldest apartments was compromised. Finally, we selected an increased ventilation flow rate of 0.4 l/s m² for the reference building, which is another option according to the code (in the case of demand-controlled operation) and is slightly higher than the original design ventilation rate of about 0.35 l/s m². Fig. 5 depicts the coldest apartment's indoor air temperature duration curve in the reference building model.

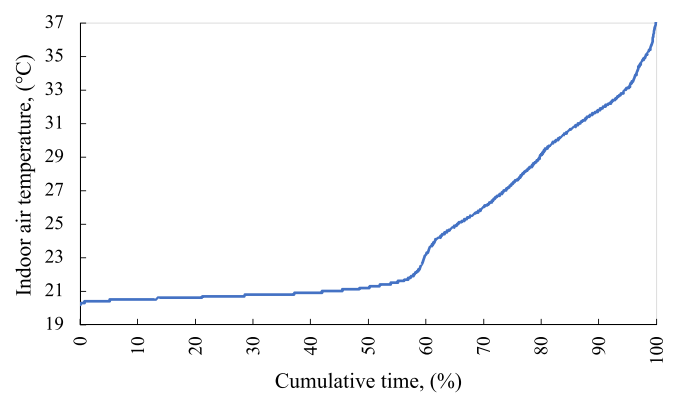

Fig. 5. The indoor air temperature duration curve of the coldest apartment in the reference building model.

2.4. Renovation packages

The formulated scenarios for the proposed renovation packages were derived from the existing ARA renovation measures. These packages can be broadly categorised into three main groups. The first category involves the integration of EAHP alongside a DH system, with concurrent consideration for window replacement and the addition of external wall

insulation. The second category combines a GSHP and EAHP, also incorporating window replacement and additional external wall insulation. The third category encompasses the utilisation of a balanced heat recovery ventilation system in conjunction with a DH system, GSHP, window replacement, and additional external wall insulation.

The IDA Indoor Climate and Energy (IDA ICE) simulation tool [41] was used to develop a calibrated model using on-site measured data from a residential building with the same parameters as the case study buildings. Then, the reference model representing the features of the typical Finnish residential buildings from 1970 was created as a baseline model to apply renovation packages. The following represent the specifications of eight distinct renovation packages, based on the most popular and some additional renovation measures in ARA subsidies. They considered with and without photovoltaic (PV) panels.

- IV. Ground Source Heat Pump (GSHP) and Exhaust Air Heat Pump (EAHP) with Window Replacement
- V. Balanced Heat Recovery Ventilation (HRV) with electric reheating coil and District Heating (DH) with Window Replacement
- VI. Balanced Heat Recovery Ventilation (HRV) with electric reheating coil and Ground Source Heat Pump (GSHP) with Window Replacement
- VII. Exhaust Air Heat Pump (EAHP) and District Heating (DH) with Window Replacement and Additional External Wall and Roof Insulation
- VIII. Ground Source Heat Pump (GSHP) and Exhaust Air Heat Pump (EAHP) with Window Replacement and Additional External Wall and Roof Insulation

Renovation package simulation with a calibrated baseline model and a detailed heat pump plant model show real achievable savings compared with calculated savings in ARA subsidies. The cost-effectiveness of popular renovation packages is analysed to identify the optimal renovation packages and those that satisfy the deep renovation requirement to reduce energy consumption by more than 60 %.

- I. Exhaust Air Heat pump (EAHP) and District Heating (DH)
- II. Ground Source Heat Pump (GSHP) and Exhaust Air Heat Pump (EAHP) with Electrical top-up
- III. Exhaust Air Heat Pump (EAHP) and District Heating (DH) with Window Replacement

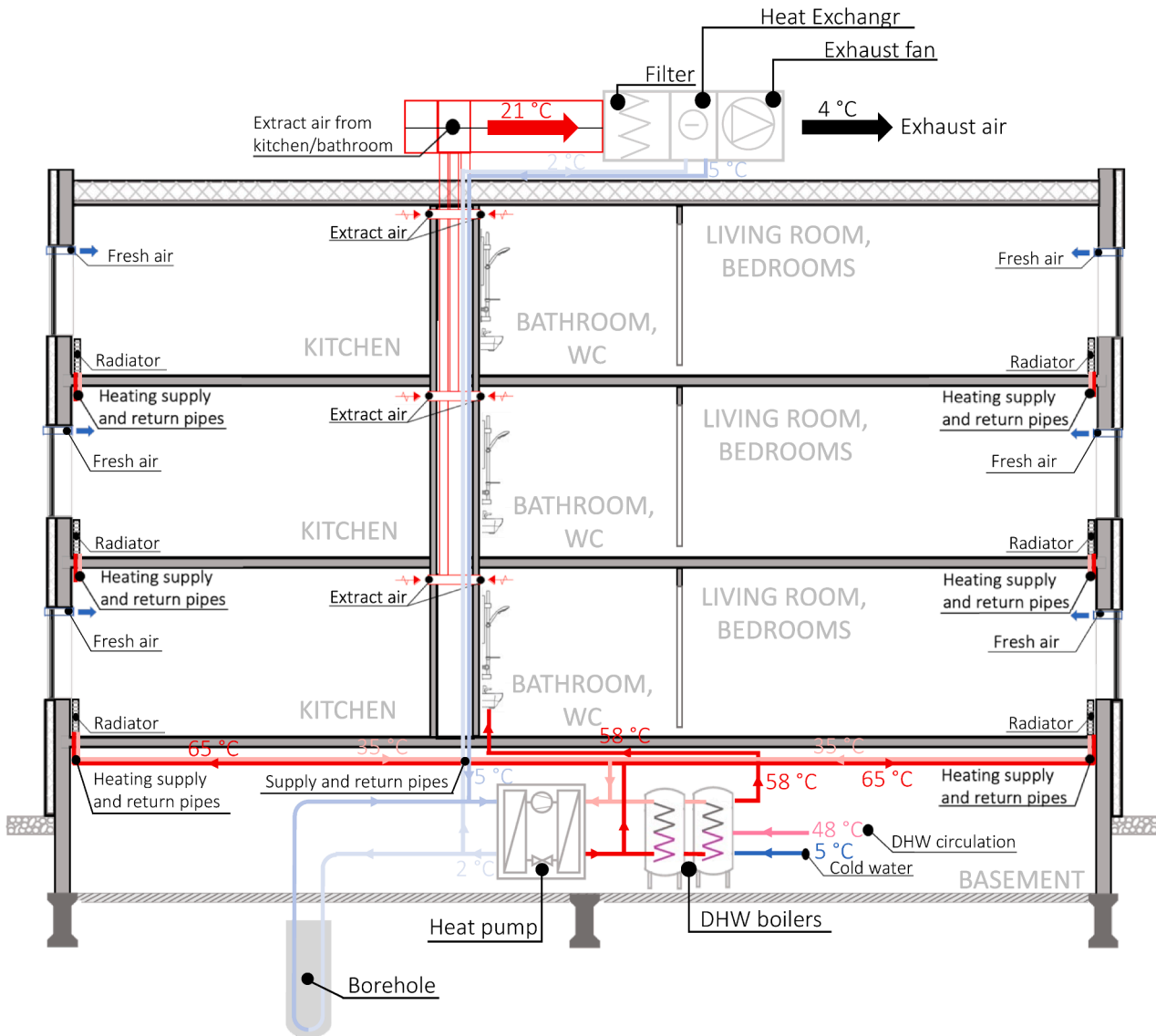

(a)

Fig. 6. The EAHP-GSHP schematic diagram (a) and its configuration in the IDAICE plant model (b).

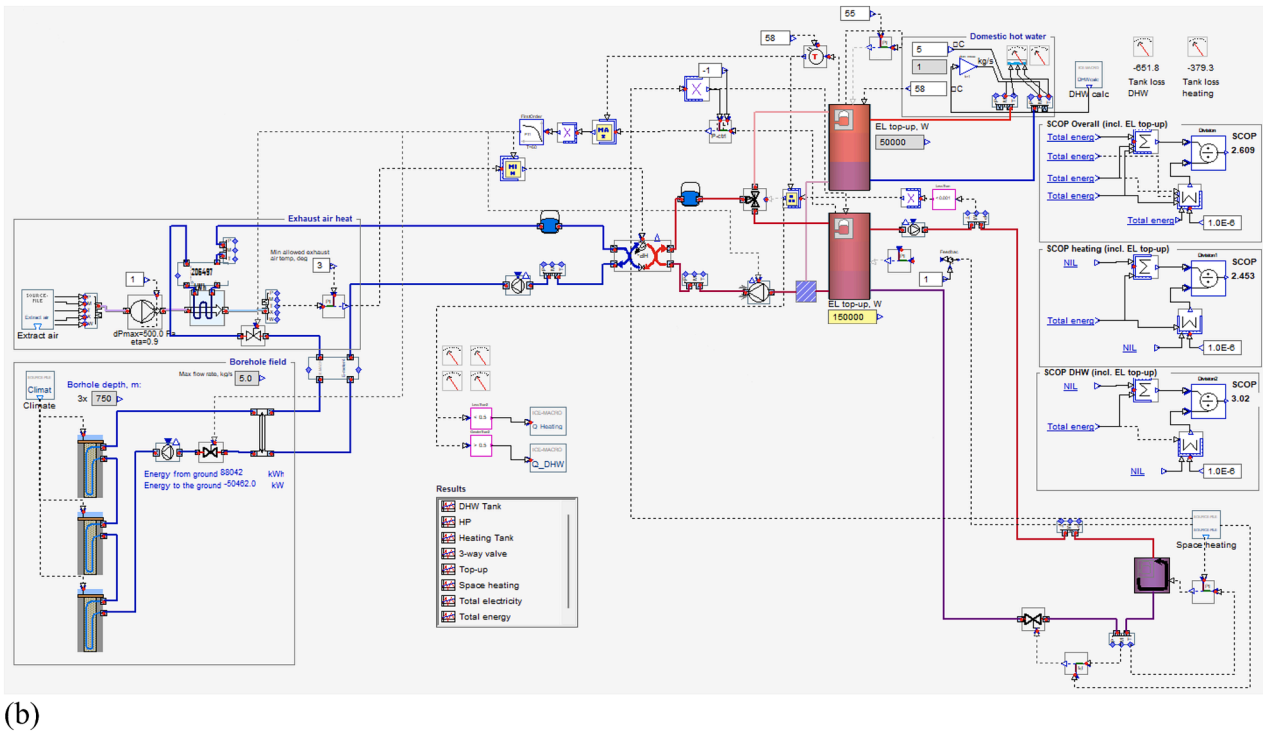

Fig. 6. (continued).

Fig. 6(a) depicts the general configuration of a combined EAHP-GSHP system to provide space heating and domestic hot water. The EAHP, which recovers heat from extracted air, is comprised of an air handling unit on the roof with a heat exchanger, exhaust fan, and filter, a heat pump unit, and a hot water storage tank in the basement. The GSHP consists of boreholes loaded with thermal grout and pipes filled with brine to extract heat from the ground. The GSHP comprises a heat pump that provides heat to the building's heating system. The EAHP and GSHP systems are designed to operate with a single heat pump and a shared loop from the EAHP air handling unit to the GSHP borehole system.

(b). The calibrated model provided the following extracted data to the EAHP-GSHP model: 1. climate file, 2. DHW volume flow, 3. extracted air mass flow, temperature, and humidity, and 4. Space heating supply and return temperature, flow rate, and power. The model was designed with a DHW priority, meaning that the tank temperature determined the switch between DHW mode and SH mode. The tank temperature was maintained within a range of 44–50 °C, and if it dropped below 44 °C, the HP automatically switched to DHW mode until the temperature reached 50 °C. In addition, the EAHP utilised the exhaust air temperature, and the exhaust air fan raised its temperature by 1 °C.

The standalone EAHP-GSHP model in IDA ICE is illustrated in Fig. 6

Table 7 reports the configuration and heating load of each

Table 7
Configuration and heating load information in renovation packages.

Renovation package	U- value, (W/m ² K)			HRV temperature ratio, %	Space Heating load, (W/m ²)	Space Heating energy need, (kWh/m ²)	Heating curve supply and return temp., (°C)	Heat pump sizing, (%)	COP at rating conditions
	External wall	Roof	Window						
EAHP + DH ¹	0.48	0.33	2.1	0	39	81	65/35	40 %	4.53
GSHP + EAHP ²	0.48	0.33	2.1	0	39	81	65/35	75 %	4.53
EAHP + DH + W ³	0.48	0.33	1.0	0	33	64	60/30	46 %	4.53
GSHP + EAHP + W ⁴	0.48	0.33	1.0	0	33	64	60/30	80 %	4.53
HRV + DH + W ⁵	0.48	0.33	1.0	80	21	30	55/30	–	–
HRV + GSHP + W ⁶	0.48	0.33	1.0	80	21	30	55/30	95 %	4.53
EAHP + DH + W + I ⁷	0.23	0.20	1.0	0	29	54	55/30	52 %	4.53
GSHP + EAHP + W + I ⁸	0.23	0.20	1.0	0	29	54	55/30	84 %	4.53

¹ Exhaust Air Heat pump (EAHP) + District Heating (DH).

² Ground Source Heat Pump (GSHP) + Exhaust Air Heat Pump (EAHP) + Electrical top-up.

³ Exhaust Air Heat Pump (EAHP) + District Heating (DH) + Window Replacement (W).

⁴ Ground Source Heat Pump (GSHP) + Exhaust Air Heat Pump (EAHP) + Window Replacement (W).

⁵ Balanced Heat Recovery Ventilation (HRV) with electric reheating coil + District Heating (DH) + Window Replacement (W).

⁶ Balanced Heat Recovery Ventilation (HRV) with electric reheating coil + Ground Source Heat Pump (GSHP) + Window Replacement (W).

⁷ Exhaust Air Heat Pump (EAHP) + District Heating (DH) + Window Replacement (W) + Additional External Wall and Roof Insulation (I).

⁸ Ground Source Heat Pump (GSHP) + Exhaust Air Heat Pump (EAHP) + Window Replacement (W) + Additional External Wall and Roof Insulation (I).

renovation package. For additional insulation, 100 mm was used in the external walls and in the roof, resulting in U-values of 0.23 W/m²K and 0.20 W/m²K, respectively. The heat recovery ventilation system with rotary heat exchanger had a temperature ratio of 80 % and a minimum exhaust air temperature of -5 °C. The table illustrates the impact of the window replacement and the enhancement of external wall insulation on reducing the heating load. As the building envelope becomes more thermally efficient due to improved insulation and reduced heat loss through windows, the amount of energy required to maintain indoor comfort decreases. Therefore, the required heating curve supply and return temperatures at design outdoor air temperature also decrease. This relationship is expected, as a lower heating load necessitates less energy to be supplied by the heat pump. The heat pump sizing is the ratio of heat pump power to the space heating load at the design outdoor temperature. This ratio varies from 40 % in the EAHP + DH package, which operates with a limited heat source of exhaust air, to 95 % in the HRV + GSHP + W package, where the heating load is the lowest. In the case of EAHP + DH, 40 % represents the maximum amount of heat possible to extract from exhaust air. Notably, the window replacement and the improvement of the external wall insulation led to a higher contribution of the heat pump and a decrease in the heating curve by 5 °C in the renovation packages employing EAHP. A similar pattern emerges within renovation packages that employed both EAHP and GSHP, wherein the heat pump power ratio demonstrates an increase coinciding with a reduction in the supply and return temperature of the heating curve. EAHP and GSHP are brine to water heat pumps for which a product model with COP = 4.53 was used. This applies at rating conditions: brine in (ethanol) at 0 °C and brine out at -3 °C, and hot water flow at 35 °C and return at 30 °C. COP values in the operation are reported in section 3.1.

Renovation packages were calculated without and with the installation of photovoltaic panels, for which all available roof space was used. In compliance with recommended guidelines, it is advisable for PV installations to cover no more than 30 % of the available roof area to mitigate shading effects and uphold the structural integrity of the building. The reference building is located in Helsinki, Finland, with a total roof area of 3405.3 m². According to these guidelines, the permissible roof area for installing PV panels would be approximately 1021.6 m². For the purpose of this analysis, we utilised 400 W solar

panels with a module efficiency of 20.2 % [42]. There were 6 rows, each containing 20 solar panels oriented to the south with a tilt angle of 25°, which is conducive to optimising energy generation. The PV panel system was characterised by its PV cell efficiency, rated at 19 %, and each individual PV panel had a rated power output of 400 W, with a total peak power of the system of 43.2 kW. It is essential to underscore that only the self-used PV-panel-generated electricity was considered when calculating the EP-value.

3. Results and analysis

3.1. Renovation packages' simulation results

The delivered energy breakdown in the reference building and renovation packages in kWh/m² is shown in Fig. 7. In the renovation packages with EAHP or GSHP, the SH and DHW electricity consumption of the heat pump is calculated individually. The same row reports a balanced heat recovery (HRV) unit supply air electric heating in two HRV cases. Thus, the delivered energy is split to DH, HP electricity or supply air electricity, electric top-up in cases without DH, fans and pumps and appliances and lighting. Essentially, there are three renovation groups. The first group involves using DH and implementing EAHP. The second one utilised the EAHP and GSHP and compensated for the remaining energy demand via electrical top-up (disconnected from DH). The third category consists of HRV + GSHP and HRV + DH combinations. In the first two categories, the energy demand is compared while windows are replaced, and the external wall's insulation thickness is increased. It is apparent that Space Heating DH and Space Heating electrical top-up account for the majority of energy consumption in renovation packages that use DH. However, the HRV + DH + W and EAHP + DH + W + I packages use the least amount of DH energy for space heating. Expectedly, the combination of EAHP and GSHP consumes the most space heating HP and supply air electricity. In the HRV + GSHP + W scenario, the Space-heating electrical top-up is minimal, while the Space-heating HP and supply air electricity are both significant. Obviously, the energy demand is reduced by window replacement and increased external wall insulation thickness. All renovation packages' simulation models used DHW priority control for the heat pump. Therefore, with the exception of the HRV + DH + W package, the DHW

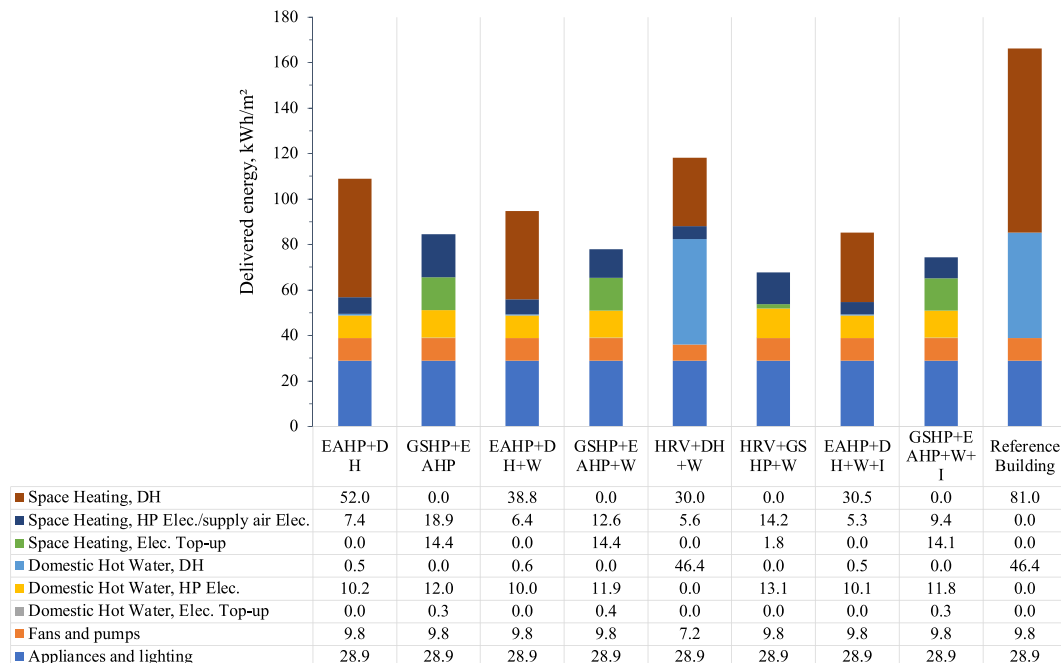

Fig. 7. The delivered energy use in different renovation packages.

DH and DHW electrical top-ups are modest in all renovation packages. The DHW heat pump electricity share is almost close between renovation packages from 10.1 to 13.1 kWh/m². Overall, the graph illustrates that the choice of renovation package has a significant impact on energy consumption, particularly in Space Heating, DHW, and Supply Air Electricity. Additionally, it highlights the effectiveness of measures like window replacement and external wall insulation improvement in reducing overall energy demand.

Fig. 8 presents the calculated EP-values for various renovation packages. The chart also includes the reference building EP-value in the form of a red dashed line, facilitating a direct comparison with the renovation outcomes. Except for the GAHP + EAHP package (EP-value = 101), all other renovation packages have EP-values of 94 or below. This suggests that most renovation packages have significantly improved energy efficiency compared to the reference building model. The chart highlights that the renovation packages HRV + GSHP + W and EAHP + DH + W + I have the lowest EP-values, indicating that these packages have achieved the highest level of energy efficiency among the options presented. The influence of two building fabric renovation measures, namely the replacement of windows and the improvement of external wall insulation thickness, is clearly observable in the chart. Packages employing EAHP and the combination of EAHP and GSHP show the most significant improvements in EP-values, demonstrating the effectiveness of these measures. Additionally, the chart shows that using GSHP in the HRV package has resulted in a substantial decrease in EP-values, signifying a notable improvement in energy efficiency. In conclusion, Fig. 8 highlights the success of various renovation strategies in improving energy efficiency, particularly the impact of heat pumps, window replacement, insulation enhancements, and the use of HRV.

The capacity, part load ratio, and control mode of the heat pump system all affect its performance [43]. Table 8 tabulates the SH and DHW Seasonal Coefficient of Performance (SCOP) and total (SH + DHW) Seasonal Performance Factor (SPF), where top-up electricity is also included for all renovation packages. The SH SCOP values in Table 8 vary between 3.2 and 4.5, and DHW SCOP values range from 2.7 to 3.6. Notably, in all renovation packages, the SCOP values for SH are consistently higher than those for DHW. The table suggests that employing a lower heating curve in the renovation packages has contributed to better SH SCOP values so that the effect of window replacement and additional insulation is clearly visible. In the case of the EAHP renovation packages, the higher source (extract) air temperature has resulted in higher SCOP values both for SH and DHW. The lowest SCOP values are in the case of GSHP only, representing the effect of a colder heat source. The total (DH + DHW) SPF values range from 2.3 to 3.9. There is a considerable drop in SPF value in renovation packages without DH (GSHP + EAHP, GSHP + EAHP + W, HRV + GSHP + W, and

Table 8

The SH and DHW Seasonal Performance Factor (SPF) in different renovation packages.

Renovation package	Seasonal Coefficient of Performance (SCOP)		Seasonal Performance Factor (SPF)
	SH	DHW	
EAHP + DH	3.8	3.5	3.7
GSHP + EAHP	3.5	3.1	2.6
EAHP + DH + W	4.1	3.6	3.8
GSHP + EAHP + W	4.0	3.1	2.6
HRV + GSHP + W	3.2	2.7	2.3
EAHP + DH + W + I	4.5	3.5	3.9
GSHP + EAHP + W + I	4.3	3.1	2.6

GSHP + EAHP + W + I). The total (SH + DHW) SPF varies from 2.3 to 3.9. A substantial decline in SPF is evident when considering renovation packages that exclude DH, i.e., GSHP + EAHP, GSHP + EAHP + W, HRV + GSHP + W, and GSHP + EAHP + W + I. This arises from the fact that the top-up electricity to support thermal comfort was considered in the SPF values calculation. In summary, Table 8 highlights the superior energy efficiency of space heating over hot water generation, the impact of the heating curve on SCOP values, and the influence of higher source air temperatures on EAHP renovation packages.

Fig. 9 displays the COP values for SH and DHW within the EAHP + DH renovation package. The graph consists of two separate “clouds” representing SH COP and DHW COP, respectively. It’s important to note that the COP values provided in this figure are derived from hourly data using IDA ICE software, which may result in a mixing of SH and DHW COP values and may not accurately represent each component’s COP. The graph clearly illustrates a relationship between outdoor temperature and both SH COP and DHW COP. As outdoor temperatures rise, both COP values tend to increase. The SH COP demonstrates a distinctive behaviour with respect to the outdoor temperature. It experiences a rapid increase in COP when the outdoor temperature is within the range of -10 °C to 7.5 °C. In contrast to the sharp rise in SH COP, the DHW COP exhibits a more gradual increase as outdoor temperatures increase. This indicates that the COP for Domestic Hot Water generation becomes more favourable with rising outdoor temperatures but at a less steep rate compared to SH.

Renovation measures incorporating heat pump systems pose the potential risk of elevating peak power demand during heating periods. Therefore, it is imperative to conduct a comprehensive analysis of the fluctuations in electrical power demand concerning various renovation strategies. Fig. 10 presents an hourly duration graph that elucidates the

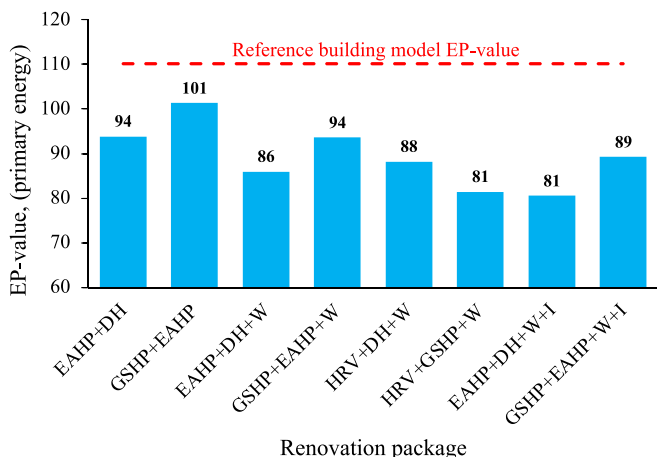

Fig. 8. The EP-value of renovation packages.

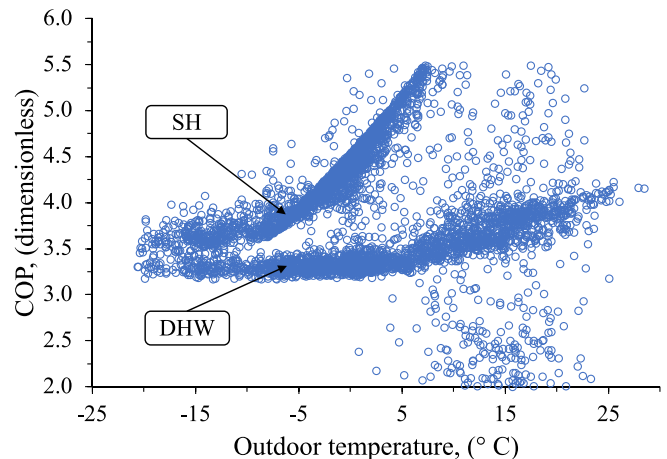

Fig. 9. The Coefficient of Performance (COP) as a function of outdoor temperature in the EAHP renovation package.

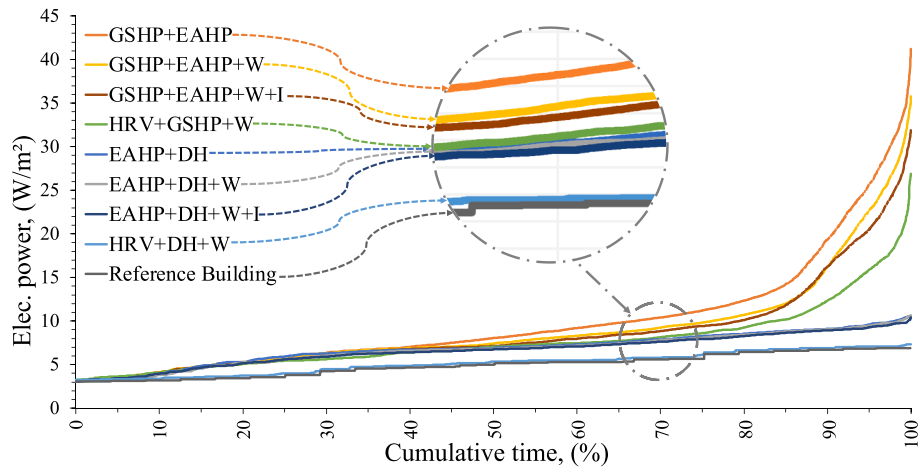

Fig. 10. The electricity power specific consumption duration curve in renovation packages.

variations in electrical power of the reference building and other renovation packages over time in W/m^2 . Notably, the combined GSHP and EAHP renovation packages have the highest electricity usage, with reductions attributed to window replacement and improvements in external wall insulation layer thickness. The GSHP + EAHP, GSHP + EAHP + W, and GSHP + EAHP + W + I renovation packages display peak specific electricity consumption values of $41.2 W/m^2$, $35.8 W/m^2$, and $31.9 W/m^2$, respectively. While the heated area is $3405 m^2$, $41.2 W/m^2$ corresponds to the absolute value of $140 kW$. The HRV + GSHP + W renovation package exhibits a lower peak electricity usage, amounting to $26.9 W/m^2$. The EAHP + DH, EAHP + DH + W, and EAHP + DH + W + I renovation packages yield peak electricity consumption values of $10.7 W/m^2$, $10.6 W/m^2$, and $10.5 W/m^2$, respectively. Following this, the HRV + DH + W renovation package demonstrates lower electricity usage compared to the other renovation packages, with a value of $7.4 W/m^2$. As expected, the reference building exhibits the lowest electricity power consumption, with a peak value of $6.9 W/m^2$. Thus, GSHP + EAHP, with the highest peak power, has resulted in the peak power increase by factor 6 compared to the reference building. Renovation packages that use DH have resulted in a relatively small increase by a factor of 1.5 and a flat duration curve. Therefore, EAHP + DH shows, by factor 3.9, a lower peak power compared to GSHP + EAHP. It should be

noted that the PV system does not change the peak power values, because there is no electricity generation at the maximum heating need.

PV self-used electricity, shown in Fig. 11, represents the proportion of electricity consumed within a building that is generated by PV panels. The self-used electricity is derived through a calculation involving the subtraction of exported electricity from the total electricity production, with the result then divided by the total electricity production. The electricity that is sold to the grid is referred to as exported electricity and is not accounted in the EP-value calculation. Fig. 11 presents the self-used electricity generated by the PV system and calculated EP-value, including the PV self-used generation across various renovation packages. The chart further incorporates the EP-value of the reference building represented by a red dashed line, allowing for a direct comparison with the renovation results. Notably, the HRV + GSHP + W renovation package stands out by utilising 52 % of the PV production, whereas the remaining packages fall within a range of 38 % to 44 % utilisation. Specifically, the GSHP + EAHP renovation package utilises 44 % of the PV generation, while the GSHP + EAHP + W and GSHP + EAHP + W + I packages both make use of 43 %. The HRV + DH + W package employs 41 % of the PV production, whereas the EAHP + DH and EAHP + DH + W + I packages each utilise 39 %. Lastly, the EAHP + DH + W package employs 38 % of the PV production. Upon comparing

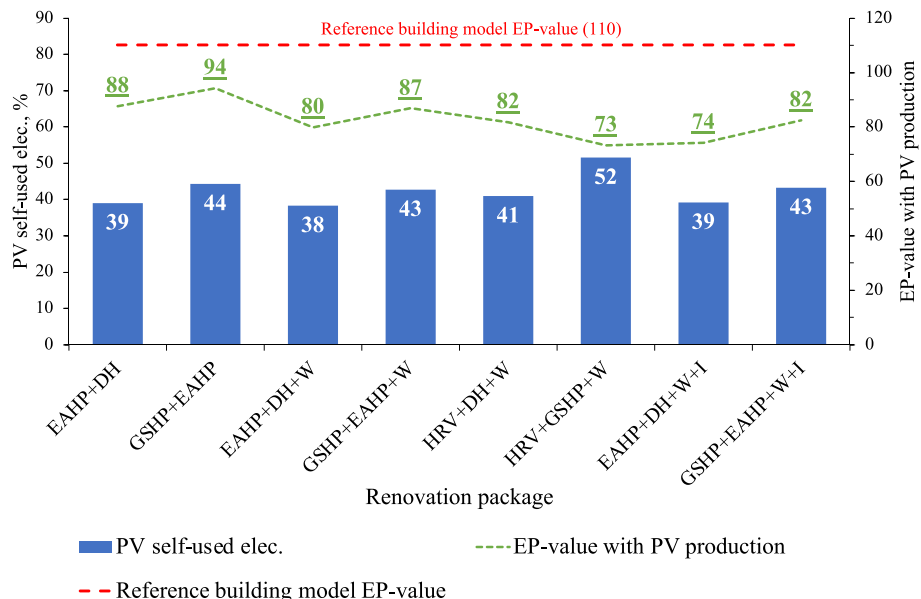

Fig. 11. The PV self-used electricity and calculated EP-value considering PV elec. production between different renovation packages.

the EP-values associated with self-used PV production against the EP-values presented in Fig. 8, it is evident that the EP-value exhibits a corresponding reduction. The most significant decline in EP-value, amounting to a 10 % reduction, is observed in the HRV + GSHP + W package, while other packages show a reduction of 7–8 %. In summary, self-used PV generation leads to an enhancement of the EP-value that keeps all renovation packages' EP-values below 90 (new building EP-value requirement in Finland) except the GSHP + EAHP renovation package.

Fig. 12 represents the duration curve of exported and delivered electricity between renovation packages considering the PV production electricity, measured in W/m^2 . “Delivered electricity” denotes the electricity purchased from the grid, while “exported electricity” represents the electricity that is sold back to the grid. Across all renovation packages considered, the average exported electricity accounts for approximately 8.8 % of the total electricity. The HRV + DH + W and HRV + GSHP + W packages illustrate the highest and lowest exported electricity at 11.9 % and 8.0 %, respectively. In terms of delivered electricity, the graph demonstrates that the duration curve for GSHP + EAHP rises rapidly, indicating higher electricity demand at high heating needs. Conversely, the HRV + DH + W package consumes the least electricity from the grid, but this still occurs 88.1 % of the time.

3.2. Economic feasibility

To assess the energy-saving cost within each renovation package, the energy cost associated with the reference building was contrasted to the costs incurred in the renovation packages. Electricity distribution tariffs, DH water flow rate charges, and the DH energy pricing structure during distinct time periods, as shown in Table 9, were taken into account. These cost parameters were derived from the pricing data provided by an energy service provider in Helsinki [44].

Fig. 13 presents the annual energy consumption and the corresponding energy-saving costs for a reference building and all renovation packages in $€/year/m^2$. The chart highlights the range of energy-saving prices, with the lowest energy-saving price attributed to the EAHP + DH renovation package and the highest to the HRV + GSHP + W renovation package. The impact of replacing windows and enhancing the external wall insulation layers on the energy-saving price is clearly evident. The renovation packages that employ a combination of EAHP + GSHP generally exhibit higher energy savings. However, while both the EAHP + DH + W + I and EAHP + GSHP + W + I renovation packages exhibit highly reduced energy usage, the former demonstrates superior energy-saving cost-efficiency. This is attributed to higher electricity usage for

Table 9

The energy price list for (a) electricity, (b) DH water flow rate, and (c) the DH energy.

(a)				
Electrical distribution tariff		Electricity		Electricity tax
Distribution, (c/kWh)	Basic charge, (€/month)	Price, (c/kWh)	Basic price, (€/month)	Price, (c/kWh)
4.07	5.51	10.09	3.54	2.794
(b)				
Water flow contract, m^3/h				Price, (€/month)
1				336.95
1.1				368.42
1.2				399.9
1.3				431.37
(c)				
Period	Months	Price including VAT (€/MWh)		
Summer period 2022	01.05.2022—30.09.2022	45.77		
Autumn period 2022	01.10.2022—31.12.2022	107.45		
Winter period 2023	01.01.2023—28.02.2023	113.53		
Spring period 2024	01.03.2023—30.04.2023	119.87		

the heat pump in the latter package, which offsets some of the energy savings.

Table 10 summarises renovation package costs and the available financial support options. The table lists the estimated renovation costs for each renovation package based on actual cost data of implemented measures, as presented in Table 4. The table also evaluates the feasibility of financial support options for these renovation packages by considering two sources of financial support: ARA renovation subsidies and bank loans available in Finland. According to ARA grant regulations, achieving a 32 % or more improvement in the EP-value results in receiving a 4000 €/apartment grant. However, if the building's EP-value is improved to the regulation level of a new building, which is EP-value 90, the subsidy is up to 6000 €/apartment. It is noteworthy that none of the simulated renovation packages meets the 32 % EP-value improvement requirement, as the highest EP-value improvement achieved is 27 % in EAHP + DH + W + I. This result is based on measured energy use and a calibrated simulation model that conflicts with data reported in EPCs, achieving about 40 % savings, Table 6. Therefore, the subsidy scheme has been based on faulty energy calculations, which highly overestimate before and after renovation energy use. It is notable that in Buildings 1 to 3, the EP-value reported in EPC after renovation is higher

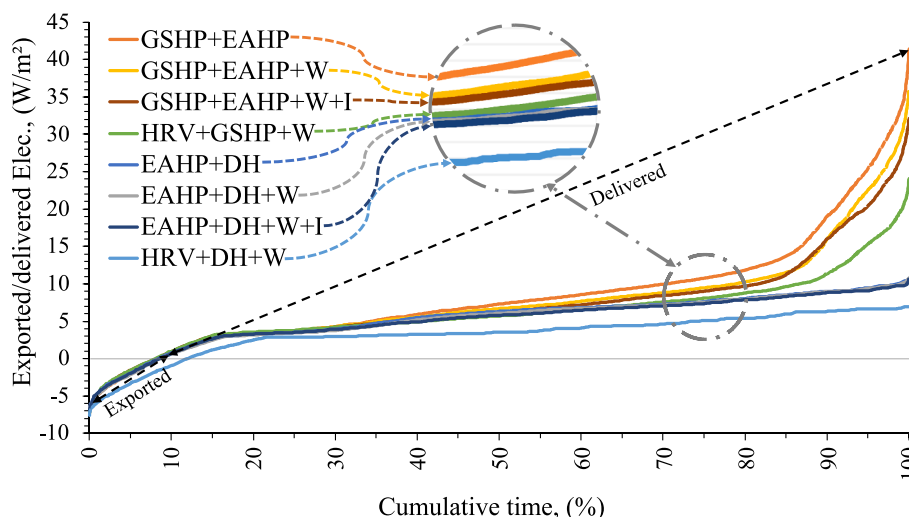

Fig. 12. The exported/delivered electricity unit load in different renovation packages considering PV production electricity.

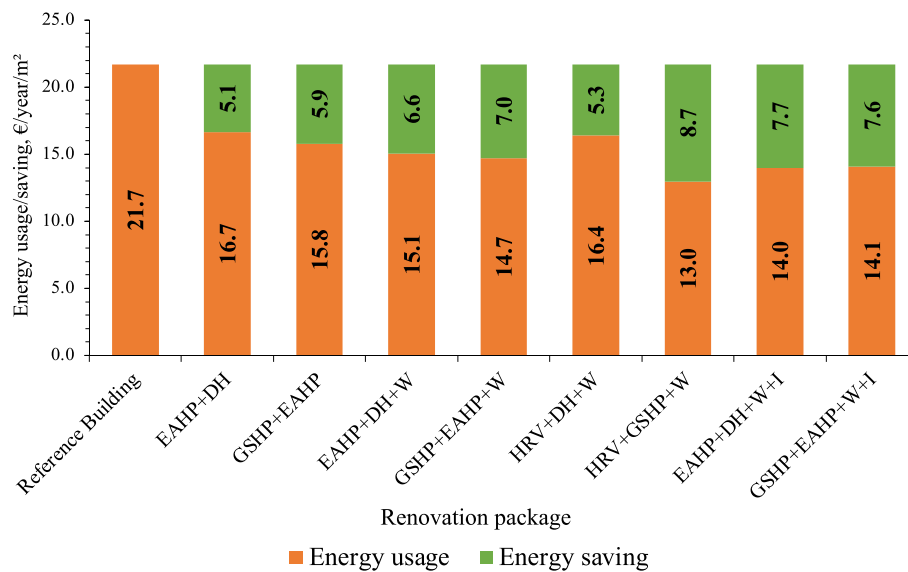

Fig. 13. The annual energy cost including both electricity and district heat and saving in different renovation packages.

Table 10 Feasible financial support to retrofit the building between different renovation cases.

Renovation package	Renovation cost, (€/m²)	ARA renovation grant		Bank loan			EP-value	EP-value improvement, %
		4000 €/apartment case, (€/m²)	6000 €/apartment case, (€/m²)	Bank loan payment, (€/month/m²)	Monthly saving, (€/m²)	Bank loan period, (Year)		
EAHP + DH	26.5	-	-	0.43	0.42	6	94	15 %
GSHP + EAHP	88.5	-	-	0.50	0.49	26	101	8 %
EAHP + DH + W	76.7	-	81.05	-	-	-	86	22 %
GSHP + EAHP + W	138.7	-	-	0.73	0.58	30	94	15 %
HRV + DH + W	-	-	-	-	-	-	88	20 %
HRV + GSHP + W	-	-	-	-	-	-	81	26 %
EAHP + DH + W + I	433.4	-	81.05	1.86	0.64	30	81	27 %
GSHP + EAHP + W + I	495.4	-	81.05	2.19	0.64	30	89	19 %

than the measured energy use EP-value before renovation.

However, for the EAHP + DH + W, HRV + DH + W, HRV + GSHP + W, EAHP + DH + W + I, and GSHP + EAHP + W + I renovation packages, EP-value remains below 90 that provides 6000 € per apartment renovation support. Given the ineligibility for ARA grants in cases where the EP-value exceeds 90 and fails to meet the 32 % improvement threshold, the table underscores that bank loans emerge as the primary means of financial support for these renovation packages. An interest rate of 4.75 % for bank loans is used [45].

For the EAHP + DH and GSHP + EAHP renovation packages, the remaining monthly savings are closely aligned with the monthly bank loan payment, resulting in bank loan durations of 6 and 26 years, respectively, indicating that these packages actually do not need renovation support. In the case of the EAHP + DH + W renovation package, the received ARA grant slightly surpasses the necessary renovation cost, obviating the need for a bank loan. Considering the maximum allowable bank loan period of 30 years, for renovation packages where costs exceed the sum of energy savings and potential ARA grants, such as GSHP + EAHP + W, EAHP + DH + W + I, and GSHP + EAHP + W + I packages, the renovation support has been clearly too small to fund these renovations.

For HRV systems, the cost calculation is not conducted because of the not available cost data. The same applies to PV systems, as they were not installed in any building, there was no cost data available and packages in Table 10 are calculated without PV; however, PV systems are

generally expected to be cost-effective.

In summary, Table 10 shows that present subsidies are not enough to have sustainable funding for deep renovation projects, including building fabric insulation measures. Furthermore, the table highlights the disparity between calculated energy savings in EPCs and real energy savings, suggesting a need for improved accuracy in initial EP-value assessments.

4. Conclusion

This study analysed renovation measures implemented with ARA renovation subsidies in Finland in multifamily apartment buildings. A typical 1970 s renovated building was identified from the ARA subsidy sample, and the reference building simulation model was calibrated using metered energy and water data from another similar building. For the reference building, a comprehensive set of renovation packages were applied to assess the performance of ARA grants. Energy analyses, electric peak power and economic analyses were conducted, allowing us to draw the following conclusions.

- The reference building simulation model calibration based on metered heating, electricity and water data showed main challenges in the assessment of the ventilation rate, modelling correct infiltration rate, using the correct setpoint for indoor air temperature and assessing DHW circulation losses. All these components were

considerably different compared to the simulation of a new building and explain failures in EPC calculations.

- The current energy calculation system, of calculated EPCs before and after renovation highly overestimated energy use and energy savings. Before the renovation, there was an overestimation of EP-value by almost a factor of 2. It was notable that in calculated EPCs, after renovation EP-value was higher than before renovation EP-value based on measured energy use. The main reasons for faulty energy calculations were strong overestimations in the building leakage rate and ventilation airflow rate. These overestimations resulted in energy savings close to 40 %, which were almost by factor 2 higher than real energy savings.
- To fix the energy calculation methodology, it can be recommended to use realistic building leakage rate q_{50} values that apply with exhaust ventilation, instead of using an equation developed for infiltration with balanced ventilation that highly overestimated infiltration airflow rates. Similarly, before renovation, ventilation rates are only about half of the code ventilation used in EPC calculation, and a more realistic value should be implemented for renovation. Our analyses recommend using a 0.4 l/s m² ventilation rate after renovation instead of the 0.5 l/s m² that has been used for new buildings.
- The renovation packages analysed included exhaust air heat pumps working in parallel with district heating, ground source heat pump combined with exhaust air heat pump, heat recovery ventilation, replacing windows and additional insulation. These demonstrated improvements in the EP-value, ranging from 8 % to 27 % when calculated with lighting and appliances included in the EP-value. With a photovoltaic electricity generation system, EP-value improvement ranged from 14 % to 34 %. A cost-effective renovation with exhaust air heat pump, window replacement and district heating reduced before renovation EP-value of 110 to 86 and with photovoltaic system even to 80, which both are less than nearly zero energy requirement of 90 to new buildings. Packages with ground source heat pump and heat recovery ventilation also showed similar savings. It should be noted that additional insulation is not cost-effective because of reasonably good initial insulation, i.e., U-values of 0.4–0.5 before renovation.
- The detailed heat pump model showed the dependency of seasonal performance factor on the heating curve and heat source temperature levels. Space heating SCOP varied between 3.2 and 4.5 and DHW SCOP 2.7 and 3.5, while the seasonal performance factor of the heating system with top-up electricity varied between 2.6 and 3.9 for renovation packages studied.
- Electricity consumption patterns showcased significant variations among renovation packages. The combined ground source and exhaust air heat pump showed the highest peak power of 41 W/m², resulting in the peak power increase by factor 6 compared to the reference building. Renovation packages that used district heat resulted in a relatively small increase by a factor of 1.5 and a flat duration curve. Therefore, the exhaust heat pump and district heating showed a factor of 3.9 lower peak power compared to the combined heat pumps. Photovoltaic system did not change the peak power values, because there is no electricity generation at the maximum heating need.
- Self-used electricity of photovoltaic generation brought all renovation packages below the EP-value of 90, with the exception of the combined ground source and exhaust heat pump package, which reached an EP-value of 94. From total photovoltaic generation, 38 % to 52 % were used in the building, depending on the renovation package.
- ARA grant eligibility condition of 32 % improvement in EP-value to receive 4000 €/apartment was not met by any renovation packages studied. This was because of faults in energy calculation guidance as five packages did qualify for the more demanding 6,000 €/apartment grant, as their EP-values remained below 90. The economic

feasibility of renovation packages varied, with the exhaust heat pump and window replacement package emerging as the most cost-effective option, while packages with additional insulation faced considerably higher costs than the sum of ARA support and monthly savings could cover bank loans; thus, ARA support was clearly too small to support the deep renovation.

To summarise, this study shows cost-effective renovation potential on multifamily apartment buildings by heat pumps, window replacement and photovoltaic, but at the same time, considerable renovation support is needed for more deep renovation where additional insulation would be applied. The need to improve the accuracy of EPCs in assessing energy performance to facilitate more effective financial support for building renovations was a finding that can be important for any support scheme. As enhancing energy performance remains a critical step in the green transition, accurate EPCs play a vital role in evaluating energy use and securing the necessary funding for such renovations. Future research in this area should continue to investigate the reliability of EPC calculations to advance the effectiveness of energy-efficient building renovations.

CRediT authorship contribution statement

Hatef Hajian: Writing – review & editing, Writing – original draft, Validation, Methodology, Data curation. **Petri Pylsy:** Software. **Raimo Simson:** Software, Formal analysis. **Kaiser Ahmed:** Validation, Software. **Paula Sankelo:** Data curation. **Alo Mikola:** Data curation. **Jarek Kurnitski:** Supervision, Project administration, Funding acquisition, Conceptualization.

Declaration of competing interest

The authors declare the following financial interests/personal relationships which may be considered as potential competing interests: Hatef Hajian reports financial support was provided by Aalto University. Hatef Hajian reports financial support was provided by Academy of Finland. Hatef Hajian reports financial support was provided by European Commission. If there are other authors, they declare that they have no known competing financial interests or personal relationships that could have appeared to influence the work reported in this paper.

Data availability

No data was used for the research described in the article.

Acknowledgement

This research was supported by the Academy of Finland (grant for DECARBON-HOME 335253 and grant for FlexiB 333365) and by the Estonian Centre of Excellence in Energy Efficiency, ENER (grant TK230) funded by the Estonian Ministry of Education and Research. The authors are grateful to ARA, The Housing Finance and Development Centre of Finland, for sharing the subsidies data for this research.

References

- [1] E. Commission, A renovation wave for europe - greening our buildings, creating jobs, improving lives, Eur. Commission vol. COM(2020) (2020) 1–26.
- [2] EPBD, “The Energy Performance of Buildings Directive (EPBD) 2018/844,” 2018.
- [3] R. Remeikienė, L. Gasparėnienė, A. Fedajev, M. Szarucki, M. Dekić, J. Razumienė, Evaluation of sustainable energy development progress in EU member states in the context of building renovation, *Energies (basel)* 14 (14) (Jul. 2021), <https://doi.org/10.3390/en14144209>.
- [4] J. Las-Heras-Casas, L.M. López-Ochoa, L.M. López-González, P. Olasolo-Alonso, Energy renovation of residential buildings in hot and temperate mediterranean zones using optimized thermal envelope insulation thicknesses: the case of Spain, *Appl. Sci* 2021 (2021) 370, <https://doi.org/10.3390/app.2021.370>.
- [5] L.M. López-Ochoa, J. Las-Heras-Casas, L.M. López-González, C. García-Lozano, Energy renovation of residential buildings in cold Mediterranean zones using

- optimized thermal envelope insulation thicknesses: the case of Spain, Sustainability (switzerland) 12 (6) (2020), <https://doi.org/10.3390/su12062287>.
- [6] T. Niemelä, R. Kosonen, J. Jokisalo, Cost-optimal energy performance renovation measures of educational buildings in cold climate, Appl. Energy 183 (2016) 1005–1020, <https://doi.org/10.1016/j.apenergy.2016.09.044>.
- [7] S. Paihio, I.P. Seppä, C. Jimenez, An energetic analysis of a multifunctional façade system for energy efficient retrofitting of residential buildings in cold climates of Finland and Russia, Sustain Cities Soc 15 (Jul. 2015) 75–85, <https://doi.org/10.1016/j.scs.2014.12.005>.
- [8] U.Y. Ayikoe Tetey, L. Gustavsson, Energy savings and overheating risk of deep energy renovation of a multi-storey residential building in a cold climate under climate change, Energy 202 (2020), <https://doi.org/10.1016/j.energy.2020.117578>.
- [9] T. van der Schoor, “Lessons From EU-Projects for Energy Renovation,” *Urban Planning*, vol. 7, no. 2. Cogitatio Press, pp. 123–130, 2022. doi: 10.17645/up.v7i2.5181.
- [10] European Commission, “Stepping up Europe’s 2030 climate ambition Investing in a climate-neutral future for the benefit of our people,” *J Chem Inf Model*, vol. 53, no. 9, pp. 1689–1699, 2020, [Online]. Available: https://knowledge4policy.ec.europa.eu/publication/communication-com2020562-stepping-europe-s-2030-climate-ambition-investing-climate_en#:~:text=17 September 2020,Communication COM%2F2020%2F562%3A Stepping up Europe’s 2030 climate,the benefit of our peopl.
- [11] European Commission, “Plan REPowerEU,” p. 21, 2022, [Online]. Available: https://ec.europa.eu/commission/presscorner/detail/es/ip_22_3131.
- [12] European Commission, “Fit for 55 - Delivering the EU’s 2030 climate target on the way to climate neutrality,” 2021. [Online]. Available: <https://eur-lex.europa.eu/legal-content/EN/TXT/?uri=CELEX:52021DC0550>.
- [13] “New rules to boost energy performance of buildings.” Accessed: Dec. 23, 2023. [Online]. Available: https://ec.europa.eu/commission/presscorner/detail/en/ip_23_6423.
- [14] UN secretary-General, Secretary-general’s remarks to the press on the war in ukraine [as delivered] | united nations secretary-general [Online]. Available: Accessed: Jul. 16 (2022) <https://www.un.org/sg/en/content/sg/press-encounter/2022-03-14/secretary-generals-remarks-the-press-the-war-ukraine-delivered>.
- [15] T.M. Lenton, et al., Tipping elements in the Earth’s climate system, Proc Natl Acad Sci U S A 105 (6) (2008) 1786–1793, <https://doi.org/10.1073/PNAS.0705414105>.
- [16] T.M. Lenton, et al., Climate tipping points — too risky to bet against, Nature 575 (2019) 592–595.
- [17] E. Pikas, J. Kurnitski, R. Liias, M. Thalfeld, Quantification of economic benefits of renovation of apartment buildings as a basis for cost optimal 2030 energy efficiency strategies, Energy Build 86 (2015) 151–160, <https://doi.org/10.1016/j.enbuild.2014.10.004>.
- [18] J. Rose, K.E. Thomsen, O.C. Mørck, M.S.M. Gutierrez, S.Ø. Jensen, Refurbishing blocks of flats to very low or nearly zero energy level—technical and financial results plus co-benefits, Energy Build 184 (Feb. 2019) 1–7, <https://doi.org/10.1016/j.enbuild.2018.11.051>.
- [19] D. Mikulić, S. Slijepčević, G. Buturac, Energy renovation of multi apartment buildings: Contributions to economy and climate changes, Energy Build 224 (2020), <https://doi.org/10.1016/j.enbuild.2020.110247>.
- [20] E. Commission, “Preliminary analysis of the long-term renovation strategies of 13 Member States,” Brussels, 2021.
- [21] D. Staniaszek, J. Kockat, and A. Vitali Roscini, “A review of EU member states’ 2020 Long-Term Renovation Strategies,” 2020. [Online]. Available: <https://www.bpie.eu/wp-content/uploads/2020/09/LTRS-Assessment-Final.pdf>.
- [22] Finnish Ministry of the Environment, “Finland Long-term renovation strategy 2020-2050 (Pitkän aikavälin korjausrakentamisen strategia 2020-2050),” 2020. [Online]. Available: <https://ym.fi/korjausrakentamisen-strategia>.
- [23] Finnish Ministry of the Environment, “Long term renovation construction strategy of Finland 2020-2050 Roadmap and executive plan 2021-2030 (Pitkän aikavälin korjausrakentamisen strategia 2020-2050 Tiekartta ja toimeenpano-suunnitelma 2021-2030),” pp. 1–71, 2020, [Online]. Available: <https://ym.fi/korjausrakentamisen-strategia>.
- [24] H.-L. Kangas, T. Vainio, P. Sankelo, S. Vesänen, and S. Karhinen, “Renovation construction in Finland strategy 2020–2050 - Goal calculation and material (Suomen-korjausrakentamisen-strategia-2020-2050-tavoitteiden-laskenta-ja-aineisto).”
- [25] T. Niemelä, R. Kosonen, J. Jokisalo, Energy performance and environmental impact analysis of cost-optimal renovation solutions of large panel apartment buildings in Finland, Sustain Cities Soc 32 (Jul. 2017) 9–30, <https://doi.org/10.1016/j.scs.2017.02.017>.
- [26] T. Niemelä, R. Kosonen, J. Jokisalo, Cost-effectiveness of energy performance renovation measures in Finnish brick apartment buildings, Energy Build 137 (2017) 60–75, <https://doi.org/10.1016/j.enbuild.2016.12.031>.
- [27] J. Hirvonen, J. Jokisalo, J. Heljo, R. Kosonen, Towards the EU emissions targets of 2050: optimal energy renovation measures of Finnish apartment buildings, Int. J. Sustain. Energ. 38 (7) (Aug. 2018) 649–672, <https://doi.org/10.1080/14786451.2018.1559164>.
- [28] J. Hirvonen, J. Jokisalo, J. Heljo, R. Kosonen, Effect of apartment building energy renovation on hourly power demand, Int. J. Sustain. Energ. 38 (10) (2019) 918–936, <https://doi.org/10.1080/14786451.2019.1613992>.
- [29] J. Hirvonen, J. Jokisalo, and R. Kosonen, “The effect of deep energy retrofit on the hourly power demand of Finnish detached houses,” *Energies (Basel)*, vol. 13, no. 7, Apr. 2020, doi: 10.3390/en13071773.
- [30] J. Hirvonen, et al., Emissions and power demand in optimal energy retrofit scenarios of the Finnish building stock by 2050, Sustain Cities Soc 70 (2021), <https://doi.org/10.1016/j.scs.2021.102896>.
- [31] A. Galimshina, et al., What is the optimal robust environmental and cost-effective solution for building renovation? Not the usual one, Energy Build 251 (2021), <https://doi.org/10.1016/j.enbuild.2021.111329>.
- [32] Ara, ARA- The housing finance and development centre of Finland [Online]. Available: Accessed (2023) https://www.ara.fi/en-US/Housing_finance/Renovation_subsidies.
- [33] “IDA ICE - Simulation Software | EQUA.” Accessed: Dec. 23, 2023. [Online]. Available: <https://www.equa.se/en/ida-ice>.
- [34] H. Hajian, K. Ahmed, J. Kurnitski, Dynamic heating control measured and simulated effects on power reduction, energy, and thermal comfort in an old apartment building with district heating, Energy Build 268 (2022) 112174, <https://doi.org/10.2139/ssrn.3921700>.
- [35] “AIVC | Air Infiltration and Ventilation Centre.” Accessed: Dec. 23, 2023. [Online]. Available: <https://www.aivc.org/>.
- [36] “Homepage - Finnish Meteorological Institute.” Accessed: Dec. 23, 2023. [Online]. Available: <https://en.ilmatieteenlaitos.fi/>.
- [37] ISO, “ISO 17772-1:2017 Energy performance of buildings — Indoor environmental quality — Part 1: Indoor environmental input parameters for the design and assessment of energy performance of buildings,” The International Organization for Standardization. Accessed: Mar. 08, 2021. [Online]. Available: <https://www.iso.org/standard/60498.html>.
- [38] “National building code of Finland (Suomen säädöskokoelma),” Helsinki, 2017.
- [39] K. Ahmed, P. Pylsy, J. Kurnitski, Hourly consumption profiles of domestic hot water for different occupant groups in dwellings, Sol. Energy 137 (2016) 516–530, <https://doi.org/10.1016/j.solener.2016.08.033>.
- [40] Finnish ministry of the Environment, “Energy efficiency- Calculation of the building’s energy consumption and heating power demand in Finland,” Helsinki, 2017.
- [41] EQUA, “IDA ICE - Simulation Software- Version 4.8.” 2024. Accessed: Jan. 23, 2024. [Online]. Available: <https://www.equa.se/en/ida-ice>.
- [42] “Best Solar Panel | 400W Black Solar Panel | Get A Quote — Solaria.” Accessed: Oct. 11, 2023. [Online]. Available: <https://www.solaria.com/400w>.
- [43] M. Abid, N. Hewitt, M.J. Huang, C. Wilson, D. Cotter, Performance analysis of the developed air source heat pump system at low-to-medium and high supply temperatures for irish housing stock heat load applications, Sustainability (switzerland) 13 (21) (2021), <https://doi.org/10.3390/su132111753>.
- [44] “District heat prices | Helen.” Accessed: Sep. 12, 2023. [Online]. Available: <https://www.helen.fi/en/heating-and-cooling/district-heat/district-heat-prices>.
- [45] “Loan calculator | Loans and homes - Private customers | OP.” Accessed: Sep. 12, 2023. [Online]. Available: <https://www.op.fi/private-customers/loans-and-homes/loan-calculator>.