

Control of plankton and nutrient limitation in small boreal brown-water lakes:
evidence from small- and large-scale manipulation experiments

Marko Järvinen

Department of Ecology and Systematics
Division of Hydrobiology
University of Helsinki
Finland

Academic Dissertation in Hydrobiology

To be presented, with the permission of the Faculty of Science of the University of Helsinki,
for public criticism in the lecture room of the Natural History Museum, P. Rautatiekatu 13,
on March 8, 2002, at 12 o'clock noon.

Helsinki 2002

Author's address Marko Järvinen
Department of Ecology and Systematics, P.O. Box 65,
FIN-00014 University of Helsinki, Finland
marko.u.jarvinen@helsinki.fi

Supervised by Dr. Lauri Arvola
University of Helsinki
Finland

 Dr. Martti Rask
Finnish Game and Fisheries Research Institute
Finland

 Prof. Kalevi Salonen
University of Jyväskylä
Finland

Reviewed by Prof. Ismo J. Holopainen
University of Joensuu
Finland

 Prof. Harri Kuosa
Finnish Institute of Marine Research
Finland

Examined by Prof. Mats Jansson
University of Umeå
Sweden

This work was supported by grants from Maj and Tor Nessling Foundation, the Academy of Finland, University of Helsinki, Finnish Game and Fisheries Research Institute, Ministry of Environment, and Nordkalk Ltd.; and by the Finnish Graduate School for Biological Interactions.

ISBN 952-91-4375-3 (Print), ISBN 952-10-0374-X (PDF)
<http://ethesis.helsinki.fi>

Yliopistopaino
Helsinki 2002

To Tarja, Matias & Jaakko

Contents

1. List of papers	1
2. The author's contribution	1
3. Abstract.....	2
4. Introduction.....	3
4.1 Environmental conditions in brown-water lakes	3
4.2 Food webs of brown-water lakes	4
4.3 Resource-based and consumer-driven control in pelagial ecosystems.....	6
4.3.1 "Bottom-up" effects	6
4.3.2 "Top-down" effects	7
4.4 Food webs of acidified and limed lakes	10
5. Objectives of the study.....	11
6. Material and methods.....	11
6.1 Study sites	11
6.2 Experimental designs.....	14
6.2.1 Liming	14
6.2.2 Nutrient enrichment bioassays	14
6.2.3 Fish manipulations	15
6.3 Physical, chemical and biological determinations.....	15
7. Results and discussion	15
7.1 Plankton community structure	15
7.2 Vertical distribution of plankton.....	19
7.3 Nutrient limitation	22
7.3.1 Phytoplankton.....	22
7.3.2 Bacterioplankton	23
7.4 Grazing control of plankton.....	25
7.5 General discussion	26
8. Conclusions.....	28
9. Acknowledgements.....	29
10. References	31

Papers I–V are reproduced by the kind permission of

Springer-Verlag (paper I)

Kluwer Academic Publishers (paper II)

Schweizerbart Publishers (paper III)

Finnish Zoological and Botanical Publishing Board (paper IV)

NRC Research Press (paper V)

1. List of papers

This thesis is based on the following papers, which are referred to by their Roman numerals:

- I. Salonen, K., Järvinen, M., Kuoppamäki, K. & Arvola, L. 1990. Effects of liming on the chemistry and biology of a small acid humic lake. *In* P. Kauppi, P. Anttila & K. Kenttämies (eds), *Acidification in Finland*. Springer-Verlag, Berlin Heidelberg, pp. 1145-1167.
- II. Järvinen, M., Kuoppamäki, K. & Rask, M. 1995. Responses of phyto- and zooplankton to liming in a small acidified humic lake. *Water Air Soil Pollut.* 85: 943-948.
- III. Järvinen, M. 1993. Pelagial ciliates in an acidified mesohumic forest lake before and after lime addition. *Verh. Internat. Verein. Limnol.* 25: 534-538.
- IV. Rask, M., Järvinen, M., Kuoppamäki, K. & Pöysä, H. 1996. Limnological responses to the collapse of the perch population in a small lake. *Ann. Zool. Fennici* 33: 517-524.
- V. Järvinen, M. & Salonen, K. 1998. Influence of changing food web structure on nutrient limitation of phytoplankton in a highly humic lake. *Can. J. Fish. Aquat. Sci.* 55: 2562-2571.
- VI. Järvinen, M., Likolammi, M., Münster, U. & Salonen, K. Effect of food web structure on the nutrient limitation of bacterioplankton and respiration of plankton in a highly humic lake. Manuscript.

2. The author's contribution

- I. KS and LA planned the experiment and supervised the work. MJ and KK conducted the sampling, field measurements, and the measurements of chlorophyll, dissolved inorganic carbon (DIC) and primary production (PP). MJ analysed phytoplankton and L. Ruuttanjärvi bacterioplankton. KK analysed zooplankton and L. Pussijärvi bacterioplankton. MJ wrote and interpreted the results of physical and chemical properties and phytoplankton communities, and contributed to general discussion.
- II. MR, LA, MJ and KK planned the experiment. MJ and KK conducted the sampling, field measurements and the measurements of chlorophyll, DIC and PP. MJ analysed phytoplankton, wrote the paper, and interpreted the results excluding the results of zooplankton done by KK. MR supervised the work.
- III. MJ wrote the paper, analysed and interpreted the results. Field work and bacterioplankton analysis were done together with KK, who also provided data on larger zooplankton. MR supervised the work.
- IV. MJ wrote, analysed and interpreted the results of water chemistry, bacterioplankton, protozoans and phytoplankton. KK, MR and HP did the same, respectively, for the results of crustacean zooplankton and rotifers, zoobenthos and fish, and waterfowl. MR supervised the work.
- V. MJ and KS planned the experiment. MJ wrote the paper, conducted all measurements (excluding nutrient analysis in the laboratory), analysed, and interpreted the results. KS supervised the work. Evo Fisheries Research Station of the Finnish Game and Fisheries Research Institute introduced the whitefish fingerlings and carried out fish sampling.
- VI. MJ and KS planned the experiment. MJ wrote the paper, conducted all measurements (excluding nutrient analysis, bacterioplankton analysis and enzyme activity studies), analysed, and interpreted the results. KS supervised the work. UM provided phosphomonoesterase activity data and ML bacterioplankton data.

MJ=Marko Järvinen, KK=Kirsi Kuoppamäki, MR=Martti Rask, KS=Kalevi Salonen, LA=Lauri Arvola, HP=Hannu Pöysä, UM=Uwe Münster, ML=Markit Likolammi.

3. Abstract

This thesis focuses on phyto- and bacterioplankton, and protozoans in five small brown-water lakes in southern Finland, and the role of nutrients and zooplankton in controlling their abundance, biomass distribution and production. Evidence of resource-based “bottom-up” and consumer-driven “top-down” effects is derived from the results of two lake liming experiments, one whole-lake food web manipulation experiment, and small-scale nutrient enrichment bioassays.

The first three studies examine the responses of plankton to lake liming in two lakes. The results indicate that biological responses to chemical manipulation can be small. The slight effect of liming on the ecosystem of L. Iso Valkjärvi was likely related to the chemical conditions during the acidified phase of the lake, and to high biological resistance, which resulted from a dense population of European perch (*Perca fluviatilis*) both during acidified and limed period. In the fishless L. Pussijärvi, the effects of liming on water chemistry were discernible only for one year due to the short water retention time. The distinct annual fluctuations in species dominance of phytoplankton in the control lake, Ruuttanjärvi, could be partly related to variations in weather, relative availability (stoichiometry) of nutrients, and possibly to variations in zooplankton community structure. The fourth study describes the ecosystem responses to an unexpected fish kill in the control side of the divided L. Iso Valkjärvi. After the collapse of the perch population, some changes in the plankton community could be related to the altered food web structure. However, the highest increase in nutrient concentrations, and bacterial and protozoan zooplankton abundance were recorded in the hypolimnion, and they likely resulted from “bottom-up” forces, i.e. decomposition of fish carcasses and the consequent release of organic matter and nutrients.

The last two studies and unpublished results from a brown-water lake, Valkea-Kotinen, showed that phytoplankton production can be limited by nitrogen (N) rather than phosphorus (P) in brown-water lakes. Moreover, the food web manipulation study in a highly humic L. Mekkojärvi showed that the nutrient stoichiometry of the zooplankton assemblage might determine the nutrient that potentially limited phytoplankton production. During the dominance of the large herbivorous cladoceran, *Daphnia longispina*, which consisted most of epilimnetic particulate P, phytoplankton production was mainly stimulated by P enrichments. After the removal of *Daphnia* from the lake, potential nutrient limitation of algae shifted towards N limitation. The changes in nutrient limitation appeared thus to be associated with the food web structure. The results of bioassays from L. Valkea-Kotinen suggest, however, that phytoplankton did not necessarily experience *in situ* nutrient limitation in these lakes. In this context, the possible role of diel vertical migrations and mixotrophy of phytoplankton in acquiring nutrients is discussed. Contrary to the findings of algal nutrient limitation, bacterioplankton production was exclusively P limited in L. Valkea-Kotinen. Enrichment bioassays on plankton respiration in L. Mekkojärvi implied that in addition to P labile organic carbon may limit bacterial growth in brown-water lakes despite high amounts of allochthonous dissolved organic carbon.

The lakes with a few or no planktivorous fish were characterised by large-sized zooplankton species. On the contrary, the lakes with dense fish populations (mainly European perch, *Perca fluviatilis*) had on the average a smaller zooplankton size distribution. This was reflected to the vertical distribution of phytoplankton biomass in the water column. In lakes with large cladocerans, the phytoplankton biomass was low in the epilimnion, which suggests a strong impact of zooplankton grazing on algae in the systems with no planktivorous fish. This could also be seen after the introduction of a new trophic level, planktivorous whitefish (*Coregonus lavaretus*) fingerlings, to L. Mekkojärvi. Several cascading effects were observed in the lake: a replacement of *Daphnia* with rotifers, an increase in phytoplankton production and biomass, an increase in protozoan biomass, and the already mentioned potential shift in phytoplankton nutrient limitation.

The results of these studies suggest that lower levels of the food web in brown-water lakes were affected both by resource availability and predator-prey interactions. It was shown that in the absence of fish, large *Daphnia* could have a central role in food web interactions. *Daphnia* could strongly regulate phytoplankton and protozoan abundance, and contribute markedly to nutrient cycling. The results also suggested that the ecosystem response to perturbations may vary due to complex trophic interactions and potential compensatory responses.

4. Introduction

Brown-water lakes are common in temperate and cold regions in the boreal zone (Kortelainen 1999a). In such lakes, dark water colour results from humus originating mainly from terrestrial ecosystems. In Finland and Sweden, the high percentage of peatlands and coniferous forests explains the abundance of brown-water lakes (Kortelainen 1999a). According to Finnish Lake Survey carried out in 1987, in 91% of Finnish lakes total organic carbon (TOC) concentration was $\geq 5 \text{ g}\cdot\text{m}^{-3}$ (Kortelainen & Mannio 1990). On a global scale, the number of brown-water lakes is vast when the lakes in Canada and Taiga region in Russia, as well as tropical blackwaters, are taken into account.

Special characteristics of brown-water lakes were already noticed in the beginning of the 20th century (Naumann 1921, Järnefelt 1925, Thienemann 1925, Birge & Juday 1927). However, not until the last 20-30 years has there been a considerable increase in the understanding of the biogeochemistry and ecology of brown-water lakes (Salonen et al. 1992a, Hessen & Tranvik 1998, Keskitalo & Eloranta 1999, Wetzel 2001). Major findings have been e.g., the understanding of the central role of allochthonous dissolved organic carbon (DOC) in fueling the upper trophic levels via the bacterioplankton-protzoan link (e.g., Salonen & Hammar 1986, Tranvik 1988, 1990, Jones 1992, Hessen 1998), a consequent net heterotrophy of brown-water lakes (Salonen et al. 1983, del Giorgio & Peters 1993, Jansson et al. 2000), and the role of photochemical degradation on the fate of allochthonous DOM (Gjessing & Gjerdahl 1970, Granéli et al. 1996, Vähätalo et al. 2000).

4.1 Environmental conditions in brown-water lakes

Brown-water lakes have some physical and chemical features divergent from those in clearwater lakes, which can affect the growth and distribution of plankton organisms.

Brown-water lakes are characterised by high concentrations of dissolved organic material (DOM) of allochthonous origin, which together with iron (Fe) explain their high water colour (Gjessing 1976, Pennanen & Frisk 1984, Meili 1992). Dark water effectively absorbs solar radiation and results in a steep thermal stratification and high thermal stability, in particular in small and sheltered lakes, and an increased extinction of light (Eloranta 1978, 1999, Jones & Arvola 1984, Bowling 1990). Besides the reduced light intensity, the penetrating light differs in quality from that of clearwater lakes with a dominance in the red part of the spectrum at deeper depths in brown-water lakes. In small and sheltered brown-water lakes, hypolimnion may become anoxic during stratified periods due to the decomposition of DOM (Salonen et al. 1984a).

During summer stratification, epilimnetic waters of these lakes generally have low concentrations of mineral nutrients, whereas the underlying hypolimnion is typically richer in nutrients (e.g., Jones 1998). In the boreal region, small brown-water lakes may stratify in the spring immediately after the ice melts which leads to an incomplete mixing of water and a consequent temporary meromixis (Salonen et al. 1984a). This increases nutrient deficiency by preventing the supply of hypolimnetic nutrients to the epilimnetic waters which would otherwise occur during spring circulation. Nutrient availability is further complicated by the metal binding properties of humic substances and the interaction of humus-Fe complexes with phosphate (Francko & Heath 1983). Humus-metal-P complexes reduce the availability of free P, but on the other hand P can be released from these compounds under P deficiency (Jones et al. 1988, De Haan et al. 1990) or by UV light (Francko & Heath 1983, Vähätalo et al. 2002) which may buffer, together with the enzymatic cleavage of biopolymers (Münster & De Haan 1998, Münster 1999), against nutrient deficiency in the system (e.g., Jansson 1998). DOM-Fe-PO₄ complexes can thus be considered as reservoirs of potential P

for the plankton (Jones 1998). DOM also reduces the precipitation of phosphate with Fe and other metals (Jones et al. 1988). A significant part of the DOM is composed of dissolved humic substances with high concentrations of organic acids which results in the naturally low pH and buffer capacity of brown-water lakes (Kortelainen & Mannio 1990, Lydersen 1998). On the other hand, dissolved humic substances also markedly contribute to the buffer capacity, which can resist anthropogenic acidification (Johannessen 1980, Kortelainen 1999b).

4.2 Food webs of brown-water lakes

Food webs are strongly driven by allochthonous organic carbon in brown-water lakes (Fig. 1, Jones 1992, Kankaala et al. 1996, Hessen 1998, Arvola et al. 1999a, Jansson et al. 2000). Autochthonous production alone cannot sustain the production at higher trophic levels in these lakes (Jones & Salonen 1985, Jones 1992, Hessen 1998), although its importance

increases with increasing eutrophication (Arvola et al. 1999b). Small brown-water lakes may have simple food webs (e.g., Salonen et al. 1992c). The short food chain length in some small brown-water lakes evidently results from the size of the lakes, because with increasing lake volume (but not necessarily with increasing primary productivity) the food web complexity increases in aquatic ecosystems (Post et al. 2000, Wetzel 2001, see also Persson et al. 1996). Although it appears that predator-prey interactions and cascading effects in brown-water lakes are likely comparable to the ones in clearwater lakes (Arvola et al. 1999a), carbon metabolism based largely on allochthonous carbon and the overall importance of the microbial loop are typical properties of food webs of brown-water lakes (Fig. 1, Hessen 1998).

High bacterial biomasses have been reported from brown-water lakes (Hessen 1985, Tranvik 1988), where allochthonous DOM is the dominating carbon source for pelagic

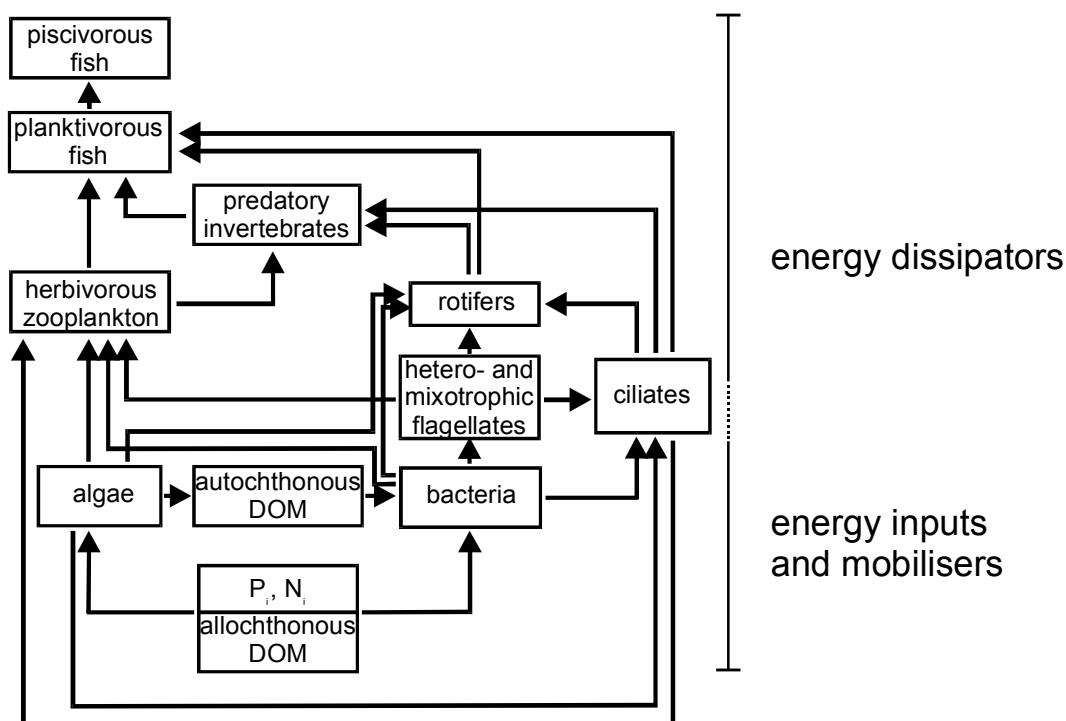

Figure 1. A generalised planktonic food web of lakes including the detritus based food chain (allochthonous DOM-bacteria-microzooplankton) which in general is the major pathway of carbon flow in brown-water lakes. Modified from Jones (1992) and Porter (1996).

bacteria (e.g., Tranvik 1988). The important role of bacterioplankton in brown-water lakes is also indicated by high plankton respiration (Salonen et al. 1983, 1992c, Hessen 1992, del Giorgio & Peters 1993). Bacterial biomasses can be an order of magnitude higher in the hypolimnion than in the epilimnion (Arvola et al. 1992). This very likely results from anoxic conditions and consequent low bacterivory (Pedrós-Alió et al. 2000). In the hypolimnion, large-sized phototrophic bacteria typically form dense, but thin, layers at depths with sufficient irradiation (Salonen et al. 1992c). These bacterial layers provide extra food for migrating zooplankton (Salonen & Lehtovaara 1992) and protozoa. Based on the carbon stable isotopic study of small forest lakes, metanotrophic bacteria of the anoxic hypolimnion might, however, be a more important C source for zooplankton than phototrophic bacteria (Jones et al. 1999).

Primary production is typically limited to the upper few meters of the water column in brown-water lakes due to strong light attenuation (Arvola et al. 1999b). On the other hand, primary production in the uppermost layers of brown-water lakes is not so severely inhibited by UV light as in clearwater lakes (Jones 1998). Despite their characteristic physical and chemical features, phyto- and zooplankton community structures in brown-water lakes seem to be rather similar to that in clearwater lakes (Jones 1998, Arvola et al. 1999b, Sarvala et al. 1999). It appears that plankton community structure is less dependent on water colour (the amount of humic substances) *per se*, but some related features such as low pH, reduced toxicity of metals, anoxia or absence of fish can affect plankton species composition and dominance (Jones 1992, 1998, Sarvala et al. 1999). Flagellated phytoplankton species have been reported to be abundant in brown-water lakes (Ilmavirta 1988, Jones 1991), because they are able to optimise their vertical distribution in relation to the available resources (light and nutrients). However, the dominance of flagellates is not a universal feature of brown-water lakes, because the same can also be

found in clearwater lakes (e.g., Arvola et al. 1999b). Although brown-water lakes have no characteristic phytoplankton species composition, cryptomonads and chrysophyceans often form high biomasses in these lakes (Jones 1998, Arvola et al. 1999b, and references therein). Cryptomonads seem to be ubiquitous in lakes (e.g., Stewart & Wetzel 1986), but their dominance in brown-water lakes might be related to their diel vertical migrations which allow the species to retrieve nutrients from nutrient-rich deeper water layers (Salonen et al. 1984b, Jones 1991, Ojala et al. 1996). The abundance of chrysophycean species may result from a high availability of chelated iron and other essential micrometals in humic waters (Jones 1998), and the fact that many chrysophycean species are mixotrophic (Jansson et al. 1996, Jansson 1998). Bergström et al. (2001) have suggested that mixotrophic flagellates dominate in small brown-water lakes because their facultative auto- and phagotrophy allow them to outcompete purely autotrophic species during nutrient limited conditions (cf. also Salonen & Jokinen 1988, Caron et al. 1990, Jansson 1998).

Most zooplankton species typical to brown-water lakes can be found in all kinds of waters (Sarvala et al. 1999). The large-sized herbivorous cladoceran, *Daphnia longispina*, is often the dominating zooplankton species in Finnish small polyhumic lakes with few or no fish (Sarvala et al. 1999). *Daphnia* can outcompete other members of the zooplankton community by efficient filter-feeding, and it also affects the abundance of its single-celled prey (e.g., Gilbert 1988, Arvola & Salonen 2001). It is also possible that *Daphnia* suppress rotifer populations by mechanical interference (Gilbert 1988). *D. longispina* can feed on a wide range of organisms in brown-water lakes (Kankaala 1988). Arnott & Vanni (1993) found no competitive suppression of small zooplankton by the large *Daphnia* in the field manipulations in fishless bog lakes in northern Wisconsin and Michigan, USA. Instead, the dominance of *D. pulex* was

strongly related to abiotic conditions (pH) and predation of small zooplankton by *Chaoborus* and *Diatomus*. Protozoan communities have seldomly been studied in brown-water lakes (Sarvala et al. 1999). The role of protozoans is, however, significant in the carbon cycling of the pelagial region of brown-water lakes, because a large part of bacterial production based on allochthonous carbon is respired or channelled to the upper trophic levels through the microbial loop (e.g., Porter 1996, Kankaala et al. 1996, Hessen 1998).

European perch (*Perca fluviatilis*), northern pike (*Esox lucius*) and crucian carp (*Carassius carassius*) typically dominate the fish communities of small headwater lakes in Finland (Rask et al. 1999). The species can tolerate well organic acidity and they can thrive in brown-water lakes despite the lack of cool and well oxygenated water. In small forest lakes of southern Finland, such as the lakes studied in this thesis, European perch can be very abundant (Rask 1991, Lappalainen et al. 1988). In such lakes, small cladoceran species like *Bosmina* and *Ceriodaphnia* often dominate zooplankton (Sarvala et al. 1999 and references therein). Headwater lakes may be devoid of fish due to environmental factors (e.g., acidity or anoxia; Lappalainen et al. 1988, Rask et al. 1999) or dispersal barriers. In lakes with no fish, invertebrate predators such as phantom midge larvae (*Chaoborus*), water boatmen (Corixidae) or backswimmers (Notonectidae) replace fish as the top predators (e.g., Eriksson et al. 1980, Stenson et al. 1978, Arnott & Vanni 1993).

4.3 Resource-based and consumer-driven control in pelagial ecosystems

Primary producers in aquatic ecosystems are affected by resources ("bottom-up" effects) and consumers ("top-down" effects) (Fig. 2, McQueen et al. 1986, 1989). Although there seems to be different "schools" among researchers, these two controlling mechanisms function simultaneously in lakes (Vanni 1996), but depending on the system

their importance may vary (e.g., Hansson 1992, Saunders et al. 2000).

4.3.1 "Bottom-up" effects

Besides light, nutrient availability is the primary "bottom-up" force that influences primary producers in the pelagial region of lakes (Fig. 2). The "bottom-up" effect can be seen strongest at trophic levels close to primary producers, and it gradually levels off and becomes unpredictable when moving towards the upper trophic levels (McQueen et al. 1986, 1989). In aquatic ecosystems, phosphorus (P) and nitrogen (N), and silica for diatoms, are the nutrients which most potentially limit phytoplankton (Hecky & Kilham 1988). The nutrient that limits the reproductive rate of a population may also vary between different algal species (Sommer 1989, and references therein). P is typically the limiting nutrient in lakes, (Schindler 1977), though in tropical lakes (Henry et al. 1985, Hecky et al. 1993) and evidently in brown-water lakes (Table 1, Jansson 1998, Saunders et al. 2000) N limitation can be frequent. The nutrient that limits algal production may, however, vary temporally and spatially in lakes depending on the input of N and P from the catchment, sediment and atmosphere (e.g., Levine & Schindler 1992) and nutrient recycling in the lake (D.E. Schindler et al. 1993, Vadstein et al. 1993, 1995). Besides the major nutrients, some trace elements may also limit algal growth. For instance, the availability of Fe is a potential limiting factor of the primary production in brown-water lakes (Jones 1992, and references therein). The availability of dissolved inorganic carbon (DIC) rarely limits the pelagial primary production (Schindler et al. 1972b), because lakes are typically supersaturated with carbon dioxide (Cole et al. 1994). In particular, the potential for C limitation of phytoplankton is unlikely in brown-water lakes due to high community respiration (Salonen et al. 1992c, Hessen 1992), methane oxidation (Hessen 1998), and photochemical mineralisation of DOC (Vähätalo et al. 2000).

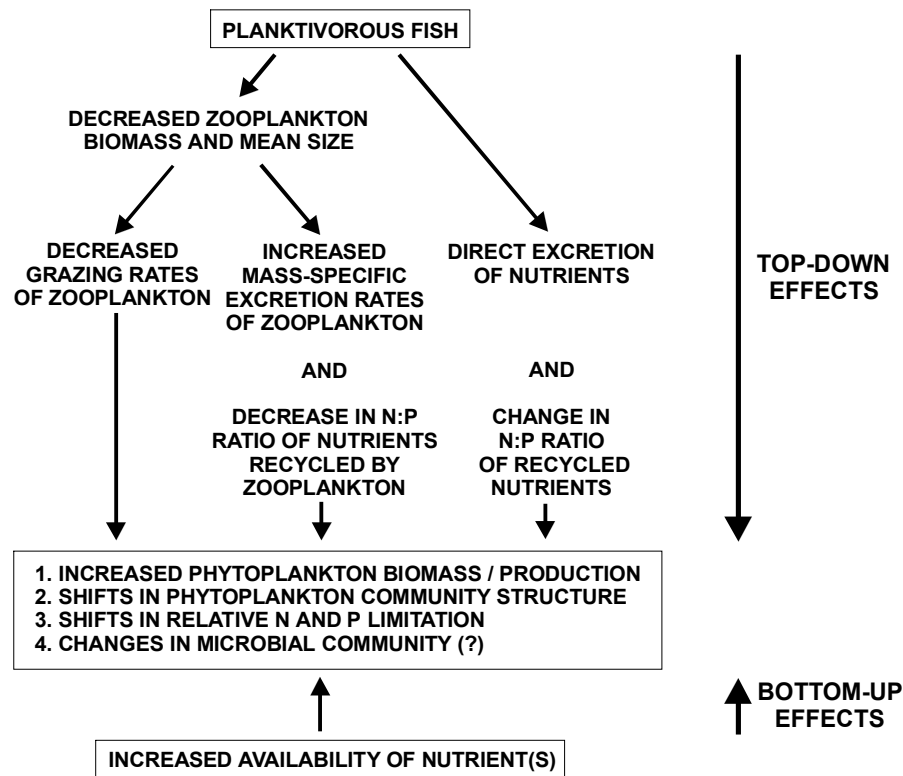

Figure 2. Mechanisms of "top-down" effects of fish and "bottom-up" effects of nutrients on phyto- and bacterioplankton in lakes. Arrows indicate the effects of planktivorous fish relative to situations in which planktivorous fish are rare. Modified from Vanni & Layne (1997).

Growth rates of bacteria are likely affected by organic and inorganic substrates in aquatic ecosystems, while the bacterial abundance and cell-size distribution are often related to bacterivory (Cole et al. 1988, Pernthaler et al. 1996, Pedrós-Alio et al. 2000, Hahn & Hofle 2001). Autochthonous DOC often forms a basis for bacterial growth in the pelagial of lakes and oceans (Cole et al. 1984, Simon et al. 1992). Allochthonous DOC provides an additional and evidently dominating C source for bacteria in brown-water lakes (Sorokin 1972, Tranvik 1988, 1992, Jones 1992, Jansson et al. 1999). Although most of allochthonous DOC is unavailable for bacteria in brown-water lakes, the available labile fraction of allochthonous DOC can be an important C source for bacteria because of the high total concentration of DOC (Tranvik 1992, 1998, Münster et al. 1999). Until recently, the availability of organic (labile) C was considered to exclusively limit bacterioplankton in aquatic ecosystems.

However, recent studies indicate that mineral nutrients, rather than organic C, often limit bacterial growth (Table 1, Coveney & Wetzel 1992, Hessen et al. 1994, Le et al. 1994, Elser et al. 1995, Jansson et al. 1996, Carlsson & Caron 2001). High amounts of allochthonous DOC may even increase a potential for the mineral nutrient limitation of bacteria in brown-water lakes (Tulonen 1992; but see also Tranvik 1998). In addition to its concentration, the molecular weight structure of allochthonous DOC also influences bacterial growth (Table 1, Tranvik 1990, 1998, Jansson et al. 1999, Bergström & Jansson 2000, Tulonen et al. 2000, Vähätalo et al. 2002).

4.3.2 "Top-down" effects

The "top-down" effect of predators on the lower trophic levels is regarded as another significant factor in structuring communities in lakes (McQueen et al. 1986, Vanni et al. 1990).

Table 1. Experimental results on the nutrient limitation of bacterio- and phytoplankton in humic waters.

Reference	Experimental design, study area	Main results
Bacterioplankton		
Arvola et al. 1996	Enclosure experiments with added humic matter and/or P in a humic lake, Pääjärvi, (southern Finland).	Bacterial production primarily limited by autochthonous DOM. Combined additions of humic matter and P also stimulated production.
Arvola & Tulonen 1998	Enrichments of the humic L. Mekkojärvi (southern Finland) inflow water or deionised water with Jaworski's medium with/without P.	Growth rate, cell numbers and biomass higher in water with allochthonous DOM. Additions of P and/or other mineral nutrients substantially stimulated bacteria.
Bergström & Jansson 2000	Bacterial production in L. Örträsket (northern Sweden) in relation to the runoff and river transport of humic material.	Lake water bacteria were stimulated by the riverine input of "fresh", less refractory, allochthonous DOC during high flow events.
Hessen et al. 1994	Enrichment experiments with humic water from L. Skjervatjern and L. Kjelsåsputten (south-eastern Norway).	Bacterial production and community respiration increased after the combined additions of glucose and mineral nutrients. A strict C limitation unlikely.
Jansson et al. 1996	Enrichment experiments with humic water from L. Örträsket.	Bacterioplankton production was P limited for most of the ice-free period.
Jones 1992, and references therein	Review: Impact of humic substances on bacterial growth.	Increased or unaltered bacterial growth and bacterial degradation of humic substances after enrichments with P and N.
K. Salonen (unpubl.)	Nutrient enrichment experiments with humic water from L. Mekkojärvi.	Bacterial growth stimulated by combined additions of P and N. No effect after single nutrient additions.
Tranvik 1990	Experiments with water from ten lakes with differing humic content (southern Sweden).	High molecular weight (MW) fractions of DOC were more available to bacteria than low MW DOC. In humic lakes, high MW DOC contributed more to bacterial growth than in clearwater lakes.
Tulonen et al. 1992	Experiments with fractionated humic water from L. Mekkojärvi.	Bacterial numbers, biomass and growth rates higher in cultures with added P and N.
Tulonen et al. 2000	Humic water from the aphotic zone of L. Pääjärvi. Impact of temperature, P and auto- and allochthonous DOM.	Highest increase in bacterial growth after a single or combined addition of allochthonous humic water and P.
Vähätalo et al. 2002	Experiments with humic water from L. Valkea-Kotinen (southern Finland) exposed or non-exposed to solar radiation.	Bacterial production and biomass higher in waters exposed to solar radiation due to increased P, N and C availability.
Phytoplankton		
Arvola et al. 1996	Enclosure experiments with added humic matter and/or P in L. Pääjärvi.	Primary production primarily P limited throughout the ice-free period.
Arvola & Tulonen 1998	Enrichment with Jaworski's medium with or without P to the humic inflow water of L. Mekkojärvi or deionised water.	Primary production increased after additions of P or other mineral nutrients. Algae grew better in a medium prepared for humic than for deionised water.
Chow-Fraser & Duthie 1987	Enrichment of a dystrophic basin, Lower Baie Philippe, of L. Matamek (Quebec, Canada) with P and N.	Phytoplankton biomass increased, but less than predicted from the documented relationships. No changes in the algal species composition.
Cottingham et al. 1998	Enrichments of three humic lakes with N and P (Wisconsin, USA).	Increased phytoplankton production and biomass and species replacements (e.g., increase in cyanobacteria).
Jones 1990	Studies of N:P stoichiometry, P uptake, and nutrient enrichments using water from three humic lakes (southern Finland).	No <i>in situ</i> P deficiency of plankton. Additions of N or Fe did not stimulate P uptake. In isolated samples, P limitation developed rapidly.
Jansson et al. 1996	Enrichment experiments with humic water from L. Örträsket.	Mixotrophic phytoplankton was N limited, while the autotrophs were co-limited by P and N.

The common view of the "top-down" effect is that the abundance of the uppermost trophic level controls the abundance of the intermediate levels, thus relieving primary producers from grazing control (Kitchell & Carpenter 1993). Accordingly, fluctuations in top predator populations can cascade through the food web to alter nutrient cycling, algal biomass and primary production (Fig. 2, Vanni & Layne 1997, Carpenter et al. 2001). It appears that large *Daphnia* is a key component for an efficient signal transfer between the top and the base of the food web and vice versa (McQueen et al. 1986, Carpenter & Kitchell 1988). In oligotrophic waters, the "top-down" effect has been suggested to be efficient at the zooplankton-phytoplankton interface (McQueen et al. 1986).

Several studies have shown the impact of fish on the plankton community structure in lakes (Hrbáček et al. 1961, Brooks & Dodson 1965, Stenson et al. 1978, Reinertsen et al. 1990, Holopainen et al. 1992, Mittelbach et al. 1995). Large zooplankton species are vulnerable to visual predation by planktivorous fish, and therefore the lakes with abundant planktivorous fish populations are composed of small-sized zooplankton species. In lakes, where planktivorous fish are controlled by piscivores or if the lake is devoid of fish, large zooplankton can dominate and the proportion of smaller zooplankton is typically low due to the predation by invertebrates (Arnott & Vanni 1993) and/or resource competition (Sarvala et al. 1999). Trophic cascades can also move sideways in the food web because several organisms occupy more than one trophic level (omnivory, life history omnivory) (Pace et al. 1998, Persson 1999). Based on the assumption of a more heterogeneous food base (autochthonous and allochthonous carbon), del Giorgio & Gasol (1995) have suggested that "top-down" effects and trophic cascades are better buffered in brown-water lakes than in more productive clearwater lakes.

At microbial level, heterotrophic nanoflagellates are the main grazers on bacteria in aquatic ecosystems (Porter et al. 1985, Sanders et al. 1989, Hahn & Hofle 2001). In lakes, ciliates (Sherr & Sherr 1987, Langenheder & Jürgens 2001), mixotrophic flagellates (Jones 1994, Jansson et al. 1999) and certain cladoceran species, like *Daphnia* (Kankaala 1988, Jürgens et al. 1994, Langenheder & Jürgens 2001), can also markedly contribute to the grazing on bacteria. Besides bacterivory, *Daphnia* can indirectly affect the bacterial communities via grazing on phytoplankton and protozoa (Salonen et al. 1992c, Jürgens et al. 1994, Glibert 1998) or through nutrient excretion (see below).

In addition to direct predator-prey interactions, the upper trophic levels may affect the nutrient availability of primary producers via the stoichiometry of consumer-driven recycling (Sterner & Hessen 1994, Sterner et al. 1997, Elser & Urabe 1999). Despite that fish appear to make in general a relatively small contribution to P regeneration in lakes (Hudson et al. 1999), nevertheless they may recycle large amounts of P (D.E. Schindler et al. 1993, Vanni et al. 1997) and sometimes even dominate the nutrient cycling (Kitchell et al. 1975, Brabrand et al. 1990, Polis et al. 1996). As already mentioned, the macrozooplankton community structure can be modified by fish predation. Although the nutrient stoichiometry of different zooplankton species varies little (molar C:P ratios from ca. 100 to ca. 200) in relation to that of bacteria or algae (Fig. 1 in Sterner et al. 1998), there are still important differences in the C:N and C:P stoichiometry between the zooplankton species (Sterner & Hessen 1994, Elser & Urabe 1999). Large herbivorous cladocerans have in relative terms more P in their body mass than copepods, whereas copepods have proportionally more N. This in turn affects the ratio of excreted nutrients. Large *Daphnia* have high body P levels (Andersen & Hessen 1991) and they can contain most of the P in the organisms (Salonen et al. 1994). Thus, *Daphnia* may be

considered as a sink of P, in particular under P deficiency, because they release proportionally less P than many other zooplankton species (Urabe 1993, Sterner & Hessen 1994). The role of protozoan zooplankton is central in nutrient recycling, since their weight-specific excretion rates for remineralised nutrients are higher than those of herbivorous metazooplankton (Caron & Goldman 1990). However, microzooplankton may also act as nutrient sinks in the absence of zooplankton predators (Lyche et al. 1996). Altogether, the nutrient regeneration by consumers depends on the elemental composition of their prey, nutrient requirements of the predator, and the structure of the food web (Caron et al. 1988, Jürgens & Güde 1990, Sterner & Hessen 1994, Glibert 1998, Elser & Urabe 1999).

4.4 Food webs of acidified and limed lakes

Atmospheric loading of sulphate and nitrate has acidified lake and river ecosystems in sensitive areas in Fennoscandia, Central Europe and North America (Rodhe et al. 1995). Key processes governing soil and water acidification and their reversibility are reasonably well known (e.g., Reuss et al. 1987, Skeffington 1992), as well as the chemical and biological impacts of acidification on freshwater ecosystems (e.g., Muniz 1991, Bell & Tranvik 1993, Havas & Rosseland 1995). The harmful effects of anthropogenic acidification mainly result from decreased pH (increased H⁺ toxicity) and increased levels of labile aluminium (Al) species which negatively affect e.g., osmoregulation, reproduction and juvenile survival of many freshwater species. This results in reduced species diversity in all trophic levels of the aquatic ecosystem and the replacement of acid-sensitive species with more resistant ones. The disappearance of top predator species, such as fish, can greatly alter the structure and functioning of acidified freshwater ecosystems (e.g., Henrikson et al. 1980, Eriksson et al. 1980, Webster et al. 1992, Appelberg et al. 1993, Pöysä et al. 1994, Appelberg 1995). Brown-water lakes

naturally have lower pH levels than the respective clearwater lakes (Kortelainen & Mannio 1990) and the organisms living in humic waters can better withstand the low pH, because humic substances reduce the toxic effects of Al (Hörnström et al. 1984) and contribute to the buffer capacity (Lydersen 1998, Kortelainen 1999b). This largely explains the higher species diversity in acidic humic waters as compared to acidic clearwater lakes (Raddum et al. 1980, Sarvala & Halsinaho 1990).

Acidified freshwaters have been limed in large-scale in Sweden and Norway, and to a lesser extent e.g., in Finland, UK, Central Europe and North America to preserve biodiversity and to mitigate the harmful effects of acidification, in particular, on valuable fish species (salmonids) and crayfish (Henrikson & Brodin 1995b). The effects of liming on a lake ecosystem can be complex, because liming affects directly and indirectly the physical, chemical and biological variables of lakes (Henrikson & Brodin 1995a). Further, some of the effects are short-lived (Hultberg & Andersson 1982, Järvinen 1993), while long-term effects may reveal themselves after a lag period of several years (e.g., Appelberg 1995). It appears that the long-term impact of liming is mostly determined by biotic factors (competition and predator-prey interactions) within the framework of post-liming abiotic conditions, and the biological communities of the limed waters will rarely, if ever, fully reach their pre-acidification state (Appelberg 1995). Liming of lakes has often coincided with the introduction of fish. Introduction or natural re-colonization of fish during the post-liming period increases the number of trophic levels, modifies predator-prey interactions, and may lead to cascading trophic interactions (cf. chapter 4.3.2). In fact, (re-)introduction of fish species immediately after lake liming complicates the interpretation of the "pure" liming effects, because many of the observed changes evidently result from fish manipulation and consequent changes in the food web interactions.

Freshwater ecosystems in Europe and North America have started to recover from acidification after reductions in acidic deposition (Järvinen & Rask 1996 and references therein, Stoddard et al. 1999). As with freshwater acidification and liming, the studies of chemical and biological recovery from acidification offer aquatic scientists a possibility to study also the biogeochemical cycles and food web interactions. The studies of recovery from acidification suggest that freshwater ecosystems will be rarely restored completely, and this often takes a long time due to the complex chemical and biological interactions (Schindler et al. 1991, Gunn et al. 1995, McNicol et al. 1995, Sampson et al. 1995, Havas et al. 1995, Stoddard et al. 1999). First, it takes time before populations respond to the altered water chemistry (Skeffington & Brown 1992). Second, although a partial recovery of the lake ecosystem will certainly occur, the extirpation of organisms during acidification from key niches may prolong the recovery time (Schindler 1990). Third, biological resiliency may prevent or slow down the establishment of circumneutral inferior competitors if the community composition has reached a new steady state during the acidic conditions (e.g., Herrman & Svensson 1995).

5. Objectives of the study

This thesis focuses on plankton communities of small boreal brown-water lakes and aims:

- 1) to estimate the role of phosphorus, nitrogen and labile organic carbon in limiting bacterio- and phytoplankton, and to study whether the changes in the food web structure can affect nutrient regeneration.
- 2) to estimate the role of zooplankton in controlling the abundance and vertical biomass distribution of phyto- and bacterioplankton and protozoan communities in lakes with or without planktivorous fish.

- 3) to estimate the response of plankton to pH related changes following lake liming.

This is done using results of nutrient enrichment bioassays, lake liming experiments and food web manipulation experiments. In addition to the results of the original papers, additional unpublished data is included in the thesis.

6. Material and methods

6.1 Study sites

The studied lakes are small brown-water lakes located in the Evo State Forest Area, Lammi, southern Finland (Fig. 3, Table 2, I–VI). The lakes are headwater lakes surrounded by coniferous forests with patches of deciduous trees and some peatland area. They have an inlet and an outlet with the exception of L. Valkea-Kotinen which lacks an inlet, and L. Iso Valkjärvi which is a seepage lake. During the summer, the lakes are thermally strongly stratified and their hypolimnia are anoxic. The lakes are typically ice-covered from late-October/November to late April/early May. In the study region, the daily mean air temperature and precipitation in June–August are 14.8 ± 3.3 °C (± 1 x standard deviation) and 2.3 ± 5.2 mm, respectively (1964–1998; meteorological station of the Finnish Meteorological Institute at Lammi Biological Station ca. 20–25 km from the study lakes).

Lake Pussijärvi

L. Pussijärvi is an acidic lake with a short water retention time (Table 2, I). The shores are overgrown by *Sphagnum* peat mosses forming characteristic mats around the lake, wherefore there is no shallow littoral area (Fig. 3). Due to the small surface area, sheltered position and dark water colour the lake can occasionally be spring meromictic. The lake has no fish.

Lake Ruuttanajärvi

L. Ruuttanajärvi has a neighbouring drainage area with L. Pussijärvi (Fig. 3, I). The lake

has a dense population of European perch (*Perca fluviatilis*; $51.7 \text{ kg}\cdot\text{ha}^{-1}$, Lappalainen et al. 1988). Spring circulation may be incomplete in L. Ruuttanjärvi. The catchment area of the lake has experienced soil fertilization due to forestry before late 1970's which explains the relatively high concentrations of phosphorus in the lake and in the incoming water (Table 2).

Lake Iso Valkjärvi

L. Iso Valkjärvi is an oligotrophic clearwater lake. However, the tree felling done in the catchment area in the mid 1980's increased water colour and the concentrations of total nutrients in the lake (Järvinen & Rask 1992). In the year of 1980, the epilimnetic water colour averaged $10 \text{ g}\cdot\text{Pt}\cdot\text{m}^{-3}$ (Arvola 1986), whereas in the beginning of this study in the year of 1990, when the lake was mesohumic, it was around $60 \text{ g}\cdot\text{Pt}\cdot\text{m}^{-3}$ (Table 2, Rask 1991, II–IV). The lake may be temporarily meromictic in spring (Jones 1990). Macrophytic vegetation is dominated by

Nuphar lutea and mats of *Warnstorfia* sp. at the bottom of the lake. The lake is characterised by the dominance of the flagellated alga, *Gonyostomum semen* (Raphidophyceae; cf. Table 4). The lake has a natural population of European perch and northern pike, whereas whitefish (*Coregonus* sp.) were introduced to the lake in small quantities more or less regularly since the late 1970's till the late 1980's. The lake is known to have been circumneutral in the late 19th century based on the abundant roach (*Rutilus rutilus*) catches recorded by the Evo State Fisheries and Aquaculture Research Station (Järvinen & Rask 1992). Acid-sensitive roach completely disappeared from L. Iso Valkjärvi some 30 years ago.

Lake Mekkojärvi

L. Mekkojärvi is a small, shallow, acidic and highly humic lake (Fig. 3, Table 2, V–VI). Floating *Sphagnum* and *Warnstorfia* mosses surround the shoreline of the lake and there is no shallow littoral area. The lake has a steep

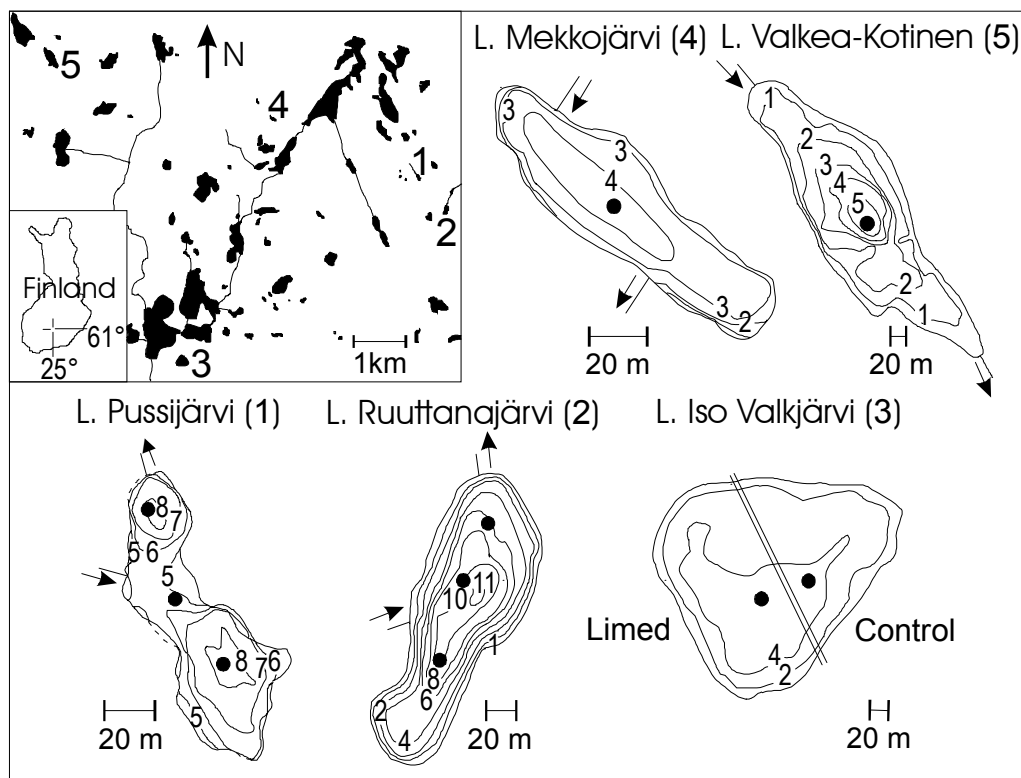

Figure 3. Location of the study lakes and their bathymetric maps. Filled circles indicate the main sampling points. Note the difference in scales.

Table 2. Characteristics of the study lakes. Selected mean epilimnetic water properties are presented for the summer period (June–August).

	Pussijärvi ¹	Ruuttanajärvi ²	Iso Valkjärvi ³	Iso Valkjärvi Control side ⁴	Iso Valkjärvi Limed side ⁴	Mekkojärvi ⁵	Valkea- Kotinen ⁶
Surface area km ²	0.029	0.01	0.039	0.016	0.022	0.004	0.041
Catchment area km ²	0.10	0.14	0.17	0.07	0.10	0.07	0.30
Maximum depth m	8.0	11.2	8.0	5.0	8.0	4.0	6.5
Mean depth m	6.6	4.9	3.4	2.9	3.8	2.0	2.5
Volume m ³	19000	47000	131200	47400	83800	8000	104000
Thermocline depth m	1–1.5	1–2	2–3	2–3.5	2–3.5	0.6–1.1	2–2.5
Anoxia below m	1.5–2	2–4	3	3–4	3.5–4	1.0–1.5	2.5–3
pH	4.8*	5.6	5.2	5.8	6.9	5.6	5.2
Alkalinity eq m ⁻³	-0.006	0.040	-0.007	0.019	0.230	0.087	0.003
Colour g Pt m ⁻³	150	200	60	50	60	310	120
DOC g m ⁻³	14	17	8	7	8	20	11
Tot-P mg m ⁻³	18	54	18	21	15	14	18
Tot-N mg m ⁻³	740	880	450	470	460	520	460
PO ₄ -P mg m ⁻³	4.5	18	1.1	1.5	1.1	1.3	<2
NO ₃ +NO ₂ -N mg m ⁻³	20	23	6	9	7	10	7
NH ₄ -N mg m ⁻³	–	–	–	7	7	2	12
Chl-a mg m ⁻³	5	16	18	23	10	8	23
Dominating zooplankton species	<i>Daphnia longispina</i> <i>Keratella cochlearis</i> <i>Polyarthra spp.</i>	<i>Bosmina longispina</i> <i>D. cristata</i> <i>Ceriodaphnia quadrangula</i> <i>Polyarthra spp.</i>	<i>B. longispina</i> <i>Ceriodaphnia quadrangula</i> <i>D. longiremis</i> <i>Kellicottia bostoniensis</i>	<i>B. longispina</i> <i>Ceriodaphnia quadrangula</i> <i>D. longiremis</i> <i>Kellicottia bostoniensis</i>	<i>B. longispina</i> <i>Ceriodaphnia quadrangula</i> <i>D. longiremis</i> <i>Kellicottia bostoniensis</i>	<i>Daphnia longispina</i> <i>K. cochlearis</i>	<i>Holopedium gibberum</i> <i>B. longispina</i> <i>Ceriodaphnia quadrangula</i> <i>Kellicottia bostoniensis</i>
Fish species and their abundance: low + high +++	–	Perch +++	Perch +++ Pike + Whitefish +	Perch +++ Pike + Whitefish +	Perch +++ Pike + Whitefish +	Pike + Tench (+)	Perch +++ Pike (+)
Treatment	Liming	–	Division into two parts	– Fish death	Liming	Fish introduction	–

¹ 1986–88, 0–1 m; ² 1986–1988, 0–1.5 m; ³ 1985–1990, 0–1 m; ⁴ 1991–1995, 0–2.5 m; ⁵ 1994, 0–1 m; ⁶ 1990–1998, 0–2 m; * 1986 & 1988.

thermal and chemical stratification, and the trophogenic layer is typically limited to the uppermost 0.5–1 m (Salonen et al. 1992b, c, V–VI). With an exception of a few northern pike, which prey on amphibians and aquatic insects, and possibly some tench (*Tinca tinca*), the lake has been without fish before the 1994 whitefish introduction (chapter 6.2.3). This is reasonable, because the lake may become totally anoxic during the ice-covered period with an exception of a limited area close to the inlet of the lake (K. Salonen, unpubl.). In the summer, zooplankton biomass is almost exclusively formed by the

herbivorous cladoceran *Daphnia longispina* (Kankaala 1988, Salonen & Lehtovaara 1992, V), which may constitute up to 85% of the particulate P in the epilimnion of the lake (Salonen et al. 1994).

Lake Valkea-Kotinen

In addition to the results of the original papers I–VI, the thesis includes unpublished data of nutrient enrichment bioassays I carried out in L. Valkea-Kotinen in 1995–1996. L. Valkea-Kotinen is a steeply stratified acidic pristine humic lake located in the Kotinen nature reserve (Fig. 3, Table 2, I. Bergström et al.

1995, Keskitalo et al. 1998, Rask et al. 1998). The catchment area of the lake consists of old virgin forest and small areas of peatland, which have been unaffected by man for at least 100 years. The lake experiences no local pollution, but it is influenced by the deposition of long-range atmospheric pollutants (Keskitalo & Salonen 1998, Rask et al. 1998). Like L. Iso Valkjärvi, L. Valkea-Kotinen is characterised by the dominance of *Gonyostomum semen* (cf. Table 4). The lake has a dense population of European perch, 2455–4930 ind·ha⁻¹, and a population of northern pike (Rask et al. 1998).

6.2 Experimental designs

6.2.1 Liming

L. Pussijärvi

One week before the melting of ice at the end of April 1987, powdered limestone (CaCO₃; 80 % of particle size of <74 µm) was spread on the ice of L. Pussijärvi (I). A band of CaCO₃ of 1–2 m in width was also spread on the shoreline of the lake. The total dose of 850 kg corresponded to an addition of 45 g·CaCO₃·m⁻³. The aim of the treatment was to increase pH above 6.0. Due to a short retention time of the lake and constant acidic input from the untreated catchment area, the effects of liming on water chemistry could be discerned only in the year of the liming (I).

L. Iso Valkjärvi

L. Iso Valkjärvi was divided watertightly into two equally sized parts with a polyethylene wall immediately following the ice melt in early spring 1991 (Järvinen & Rask 1992). The western part of the lake was limed with a finely ground limestone powder (CaCO₃) in late May 1991. The dose of 3050 kg corresponded to an addition of 36.4 g·CaCO₃·m⁻³ (Weppling et al. 1992). The powder had a CaCO₃ content of 96.1%, the most important impurities being magnesium (1.8%) and silica (1.5%). The aim of the treatment was to increase pH and alkalinity of the limed part to 6.5–7.0 and 0.20–0.25 meq·l⁻¹, respectively, for at least 3–5 years. The

original polyethylene wall leaked neutralised water from the hypolimnion of the limed part to the control part of the lake in early spring 1992 (II). To avoid any further leakage between the lake parts, an additional polyethylene wall was installed next to original one in August 1992 (Fig. 3). The duration of CaCO₃ treatment has lasted longer in the water chemistry than what was originally targeted (Järvinen et al. 1995, unpubl.).

6.2.2 Nutrient enrichment bioassays

L. Mekkojärvi

In situ nutrient enrichment bioassays with 200-µm screened epilimnetic (0–0.5 m) water were conducted weekly in 20-ml or 50-ml bottles both before and after the introduction of fish to the lake (see 6.2.3) in June–August 1994 (V–VI). Phosphate-P, ammonium-N and labile organic carbon (glucose) were added separately and in all combinations in a 2x2x2 factorial design to final concentrations of 1.6 µmol·P·l⁻¹, 25.0 µmol·N·l⁻¹, and 41.7 µmol·C·l⁻¹, respectively. Additional enrichments with nitrate-N and urea (CO(NH₂)₂) were conducted during the study. Primary production and plankton respiration were generally measured 1 and 5 days after the beginning of the experiments (¹⁴C and DIC methods, respectively; Table 3).

L. Valkea-Kotinen

In situ nutrient enrichment bioassays with 200-µm screened epilimnetic (0–1 m) water were conducted weekly in June–August 1995 and three times in 1996 (M. Järvinen & K. Salonen, unpubl.). Phosphate-P, ammonium-N and glucose were added separately and in all combinations in a 2x2x2 factorial design to final concentrations of 0.62 µmol·P·l⁻¹, 10.0 µmol·N·l⁻¹, and 41.7 µmol·C·l⁻¹, respectively. After nutrient additions, 1-litre open containers were pre-incubated for 2-d in the lake under a UV-cutting transparent shield. After this, duplicate subsamples of 20-ml were taken from the containers to acid-purged and combusted (450 °C, 4 h) scintillation vials for the determination of primary production (¹⁴C method, 4-h incubation under

constant light; Schindler et al. 1972a, Keskitalo & Salonen 1994) and bacterial production (^{14}C -leucine method, 1-h incubation; Kirchman 1993), respectively. In addition, the *in vivo* fluorescence of the sample water was determined with a Turner 10-AU-005 field fluorometer (CS5-60 excitation filter, 2-64 emission filter, daylight white lamp, a red sensitive photomultiplier) at the beginning and at the end of the experiments.

6.2.3 Fish manipulations

L. Mekkojärvi

One thousand individuals of whitefish fingerling of the year (0+) 4–6 cm in length were introduced to L. Mekkojärvi in mid-July 1994 (V–VI). The idea behind the planktivorous fish introduction was to biologically remove the large-sized and dominating *Daphnia longispina* from the lake, and to follow the responses of the ecosystem to the changed food web structure. Anoxic water below the depth of 0.6–0.9 m restricted the distribution of whitefish to the uppermost water layer. Three weeks after the introduction of fish, all *Daphnia* disappeared from the lake (V). Two mesocosms of a diameter of 2 m were installed to the lake before the fish introduction for radiotracer studies of P cycling (K. Salonen, unpubl.). In the mesocosms, *Daphnia* remained the dominating zooplankton species throughout the summer, which indicates that the disappearance of the species in the lake resulted from predation by the introduced planktivorous fish (V).

L. Iso Valkjärvi

The perch population of L. Iso Valkjärvi was mostly composed of fish of the abundant 1988 year-class (Rask 1991, IV). An almost complete killing of the perch population took place in the control part of L. Iso Valkjärvi in September 1992, which decreased the density of perch from 1800 ha^{-1} to $<50 \text{ ha}^{-1}$ (IV). This likely resulted from the so-called mixing zone effect (Rosseland et al. 1992): an unfavourable interaction of low pH, calcium and labile aluminium in certain

concentrations, which is detrimental to fish. In L. Iso Valkjärvi, the fish kill was also related to autumn turn-over and consequent changes in the Redox potential and the concentration of iron (Fe) (IV). The unexpected fish kill disturbed the original experimental design, but it offered a possibility to estimate the controlling role of perch in the ecosystem of the lake.

6.3 Physical, chemical and biological determinations

The methods used in the studies I–VI are summarized in Table 3.

7. Results and discussion

7.1 Plankton community structure

Phytoplankton species composition in the studied lakes (Table 4, Figs. 6–7 in I, Table 1 in II) was typical for boreal brown-water lakes (e.g., Ilmavirta 1983, Eloranta 1995, Jones 1998, Arvola et al. 1999b, Lepistö 1999). Cryptomonads and chrysophytes were abundant, while the contribution of diatoms to the total algal density and biomass was typically low. However, the biomass dominance of the acidophilic diatom *Asterionella ralfsii* in L. Pussijärvi (I), the increased biomass of the diatom *Fragilaria ulna* m. "acus" after liming in L. Iso Valkjärvi (II), and the abundance of *Rhizosolenia longiseta* in L. Valkea-Kotinen (Table 4, A.-L. Holopainen, unpubl.) indicated that turbulent mixing was sufficient for diatoms even in these small and rather sheltered lakes. It is possible that diatoms are lacking from many brown-water lakes simply because of low silica concentrations (Arvola et al. 1999b). For instance, *F. ulna* probably increased following liming in L. Iso Valkjärvi due to impurities of Si in the added CaCO_3 (theoretical enrichment $550 \text{ mg}\cdot\text{Si}\cdot\text{m}^{-3}$; Wepppling et al. 1992) and reduced acidity (II). A similar increase in Si concentration and *Fragilaria nana* (*Synedra nana*)

Table 3. Summary of the methods used in papers I–VI.

Measurement	Method	Reference
Temperature and oxygen	YSI temperature and oxygen probe, <i>in situ</i> measurement	Wetzel & Likens 1991
Light penetration	Secchi disc, Li–Cor, LI–190Sa quantum sensor	Li–Cor 1982
pH *	Orion Research 701 or SA 720 pH meter	APHA 1985
Alkalinity *	Gran titration	Mackereth et al. 1978
Conductivity *	Conductivity meter	APHA 1985
Water colour *	0.2- μ m or GF/C filtration, absorption at 420 nm, Platinum-cobalt standards; Hitachi 101 or Shimadzu UV–2100 spectrophotometer	
Inorganic carbon	Acidity infrared method; Universal carbon analyser	Salonen 1981
Organic carbon *	Combustion infrared method; Universal carbon analyser	Salonen 1979
Nitrate+nitrite *	Cadmium reduction method; AKEA autoanalyser	Wood et al. 1967
Ammonium *	Modified phenate method; Shimadzu UV–2100 spectrophotometer	Solórzano 1969
Inorganic phosphorus *	Molybdate method; AKEA autoanalyser	Murphy & Riley 1962
Total nitrogen and phosphorus *	Alkaline persulphate digestion; AKEA autoanalyser	Koroleff 1983
Particulate nitrogen and phosphorus *	Filtration onto preignited Whatman GF/F filters, alkaline persulphate digestion; AKEA autoanalyser	Koroleff 1983
Dissolved total nitrogen and phosphorus *	Preignited Whatman GF/F filtrates, alkaline persulphate digestion; AKEA autoanalyser	Koroleff 1983
Chloride and sulphate *	Dionex 2001i ion chromatograph	APHA 1985
Iron*	Varian Techtron 1000 atomic absorption spectrophotometer	APHA 1985
Total-aluminium *	Catechol violet reagent	Dougan & Wilson 1973
Calcium, Magnesium, Sodium, Potassium *	Varian Techtron 1000 atomic absorption spectrophotometer	APHA 1985
Chlorophyll	Ethanol extraction at room temperature; Shimadzu UV–240 or UV–2100 spectrophotometer, or Hitachi F–4000 fluorescence spectrophotometer	Lorenzen 1967, Jespersen & Christoffersen 1987
Bacterioplankton	Epifluorescence microscopy, acriflavine staining; measurement of biovolume from cell dimensions, conversion to carbon biomass	Bergström et al. 1986, Tulonen 1993
Phytoplankton density	Settling chamber technique	Utermöhl 1958
Phytoplankton biomass	Wet weight from algal biovolumes measured for the dominant species or given in the literature	Naulapää 1972, E. Willén et al. 1985, Tikkanen & Willén 1992, Utermöhl 1958, III
Protozoans	Settling chamber technique, counting of cells from half of the bottom of the chamber	
Metazooplankton	50- μ m plankton mesh net, preservation with formaldehyde or chilled sugar-formaldehyde solution, rotifers: inverted microscopy, crustaceans: dissection microscope, C content by high temperature combustion or values from literature	Prepas 1978, Keskitalo & Salonen 1994, Latja & Salonen 1978, McCauley 1982, Hakala 1971
Plankton respiration	Increase in DIC in dark bottles; Universal carbon analyser	Keskitalo & Salonen 1994
Primary production	14 C method; Wallac 1210 Ultrobeta or Wallac 1400 Scintillation Counter	Schindler et al. 1972a, Keskitalo & Salonen 1994
Bacterial production	Incorporation of 14 C leucine; Wallac 1400 Scintillation Counter	Kirchman 1993, Tulonen 1993
Phosphomonoesterase activity	Increase in fluorescence during 10 min incubations with 4-methyl-umbelliferyl-(4MUF)-phosphate at 15 °C; Hitachi F–4000 fluorescence spectrophotometer	Hoppe 1983 Münster et al. 1989
Nitrogen and phosphorus in zooplankton *	Drying at 60–65°C, persulphate digestion; AKEA autoanalyser	Koroleff 1983
Nitrogen and phosphorus in fish *	Dried pulverised samples mixed with deionised water, persulphate digestion; a mortar and pestle, an electrobalance, AKEA autoanalyser	Koroleff 1983

* = determinations generally made by the laboratory staff of the Lammi Biological Station.

Table 4. Phytoplankton taxa which contributed >20% of the total algal density (D), biomass (B), or both (no label) in the epilimnion of the studied lakes in June-August.

Pussijärvi ¹	Ruuttanajärvi ²	Iso Valkjärvi IVA ³	IVA, Control side ⁴	IVA, Limed side ⁴	Mekkojärvi ⁵	Valkea-Kotinen ⁶
CRYPTOPHYCEAE <i>Cryptomonas gracilis</i> <i>C. ovata</i>	CYANOPHYCEAE <i>Anabaena circinalis</i> B	CHRYSOPHYCEAE <i>Chrysoococcus rufescens</i>	CRYPTOPHYCEAE <i>Cryptomonas gracilis</i> <i>C. ovata</i> B	CRYPTOPHYCEAE <i>Cryptomonas gracilis</i> <i>C. ovata</i> B	CYANOPHYCEAE Small colony D	CRYPTOPHYCEAE <i>Cryptomonas</i> spp.
DINOPHYCEAE <i>Glenodinium</i> sp. B <i>Gymnodinium</i> sp. B	CRYPTOPHYCEAE <i>Cryptomonas gracilis</i> <i>C. ovata</i> <i>C. sp. B</i>	RAPHIDOPHYCEAE <i>Gonyostomum semen</i> CHLOROPHYCEAE <i>Chlamydomonas</i> sp. D	DINOPHYCEAE <i>Gyrodinium</i> sp. D <i>Peridinium goslaviense</i> B <i>P. inconspicuum</i> B	DINOPHYCEAE <i>Gyrodinium</i> sp. D PRYMNESIOPHYCEAE <i>Chrysochromulina</i> sp. D	CRYPTOPHYCEAE <i>Cryptomonas gracilis</i> <i>C. ovata</i> B <i>Rhodomonas lacustris</i>	CHRYSOPHYCEAE <i>Chrysocapsa planctonica</i> <i>Dinobryon bavaricum</i> <i>Pseudopedinella</i> sp. D <i>Uroglena americana</i>
PRYMNESIOPHYCEAE <i>Pavlova</i> sp. D	PRYMNESIOPHYCEAE <i>Chrysochromulina</i> sp. D <i>Pavlova</i> sp. D	CONJUGATOPHYCEAE <i>Closterium acutum</i> var. <i>variable</i>	PRYMNESIOPHYCEAE <i>Chrysochromulina</i> sp. D	PRYMNESIOPHYCEAE <i>Chrysochromulina</i> sp. B <i>Peridinium</i> sp. B	DINOPHYCEAE <i>Gymnodinium</i> sp. B <i>Peridinium</i> sp. B	DIATOMOPHYCEAE <i>Rhizosolenia longiseta</i> B
CHRYSOPHYCEAE <i>Chromulina</i> sp. <i>Chrysooccus cordiformis</i> <i>Dinobryon crenulatum</i> D <i>D. divergens</i> D <i>Mallomonas caudata</i> B <i>M. heterospina</i> <i>M. sp.</i> <i>Pseudopedinella</i> sp. D <i>Spiniferomonas</i> sp. D <i>Uroglena</i> sp.	CHRYSOPHYCEAE <i>Pseudopedinella</i> sp. D <i>Ochromonas</i> sp. <i>Uroglena</i> sp. B DIATOMOPHYCEAE <i>Fragilaria ulna</i> m. "ulna" B PRASINOPHYCEAE <i>Monomastix</i> sp. D	CHRYSOPHYCEAE <i>Chrysooccus rufescens</i> <i>Dinobryon divergens</i> <i>Pseudopedinella</i> sp. D <i>Chrysostephanosphaera globulifera</i> <i>Dinobryon divergens</i> <i>Pseudopedinella</i> sp. B <i>Uroglena</i> sp.	CHRYSOPHYCEAE <i>Chrysooccus rufescens</i> <i>Dinobryon divergens</i> <i>Pseudopedinella</i> sp. D <i>Chrysostephanosphaera globulifera</i> <i>Dinobryon divergens</i> <i>Pseudopedinella</i> sp. B <i>Uroglena</i> sp.	CHRYSOPHYCEAE <i>Chrysooccus rufescens</i> <i>Dinobryon divergens</i> <i>Pseudopedinella</i> sp. D <i>Mallomonas atrokomos</i> B <i>M. caudata</i> B <i>M. sp. B</i> <i>Ochromonas</i> sp. <i>Pseudopedinella</i> sp. <i>Uroglena</i> sp.	CHRYSOPHYCEAE <i>Chromulina</i> sp. D <i>Mallomonas atrokomos</i> B <i>M. caudata</i> B <i>M. sp. B</i> <i>Ochromonas</i> sp. <i>Pseudopedinella</i> sp. <i>Uroglena</i> sp.	RAPHIDOPHYCEAE <i>Gonyostomum semen</i> PRASINOPHYCEAE <i>Monomastix</i> sp. D CHLOROPHYCEAE <i>Oocystis lacustris</i> D
DIATOMOPHYCEAE <i>Asterionella ralfsii</i> <i>Aulacoseira</i> sp.	CHLOROPHYCEAE <i>Dictyosphaerium pulchellum</i> D <i>Koliella longiseta</i> <i>K. spiculiformis</i> <i>Spermatozopsis exsultans</i> D	CHLOROPHYCEAE <i>Dictyosphaerium pulchellum</i> D	RAPHIDOPHYCEAE <i>Gonyostomum semen</i> CHLOROPHYCEAE <i>Dictyosphaerium pulchellum</i> D	RAPHIDOPHYCEAE <i>Gonyostomum semen</i> B UNIDENTIFIED Flagellate 2-3 µm D	PRASINOPHYCEAE <i>Monomastix</i> sp. D UNIDENTIFIED Flagellate 1-3 µm D	PRASINOPHYCEAE <i>Monomastix</i> sp. D CHLOROPHYCEAE <i>Oocystis lacustris</i> D
PRASINOPHYCEAE <i>Monomastix</i> sp. <i>Spermatozopsis exsultans</i> D	PRASINOPHYCEAE <i>Monomastix</i> sp. D CHLOROPHYCEAE <i>Dictyosphaerium pulchellum</i> D <i>Koliella longiseta</i> <i>K. spiculiformis</i> <i>Spermatozopsis exsultans</i> D	CONJUGATOPHYCEAE <i>Closterium acutum</i> var. <i>variable</i> D	RAPHIDOPHYCEAE <i>Gonyostomum semen</i> CHLOROPHYCEAE <i>Dictyosphaerium pulchellum</i> D	RAPHIDOPHYCEAE <i>Gonyostomum semen</i> B UNIDENTIFIED Flagellate 2-3 µm D	PRASINOPHYCEAE <i>Monomastix</i> sp. D UNIDENTIFIED Flagellate 1-3 µm D	CHLOROPHYCEAE <i>Oocystis lacustris</i> D
CHLOROPHYCEAE <i>Koliella longiseta</i> D <i>Oocystis lacustris</i> <i>Phacotus</i> sp. B <i>Sphaerocystis schroeteri</i>	CONJUGATOPHYCEAE <i>Closterium gracile</i> B <i>C. macilentum</i> B	UNIDENTIFIED Flagellate 2-3 µm D	UNIDENTIFIED Flagellate 2-3 µm D	UNIDENTIFIED Flagellate 2-3 µm D	UNIDENTIFIED Flagellate 1-3 µm D	CHLOROPHYCEAE <i>Oocystis lacustris</i> D
CONJUGATOPHYCEAE <i>Desmidiium schwarzii</i> B	UNIDENTIFIED Flagellate 2-3 µm D	UNIDENTIFIED Flagellate 2-3 µm D	UNIDENTIFIED Flagellate 2-3 µm D	UNIDENTIFIED Flagellate 2-3 µm D	UNIDENTIFIED Flagellate 1-3 µm D	CHLOROPHYCEAE <i>Oocystis lacustris</i> D

¹ 1986-88, 0-1 m; ² 1986-1988, 0-1.5 m; ³ 1990, 0-1 m; ⁴ 1991-1993, 0-2 m; ⁵ 1994, 0-1 m; ⁶ 1996-1996, 0-2 m; unpubl. data (A.-L. Holopainen).

abundance was found after liming of L. Gårdsjön, Sweden (Larsson 1988). Rask et al. (1993) reported increased numbers of diatoms in a small brown-water lake, Nimetön, in southern Finland after clear cutting and slash burning of the catchment area of the lake. Decrease in the shelter from wind increased mixing in this formerly meromictic lake, but it is likely that besides the increased turbulence, also the increased nutrient load favoured the diatoms.

Except for the drastic short-term decrease of the biomass of phytoplankton and protozoans immediately after the lime addition (II, Järvinen 1993), and the increased abundances of *F. ulna* and the cryptomonad *Rhodomonas lacustris*, liming of L. Iso Valkjärvi did not noticeably affect the phytoplankton community structure (II) or the protozoan zooplankton (III). This likely resulted from the relatively high concentration of DOC in the lake (cf. Table 2) which can buffer against the negative effects of acidity (e.g., Hörnström et al. 1984, Larsson 1995), the ambient low concentration of labile Al (II, IV, Mannio 1993), the rather "high" pH level (5–5.5) during the acidic phase (Rask 1991), and from the fact that liming caused only minor changes in nutrient concentrations (II, Järvinen et al. 1995). Furthermore, the zooplankton community structure and biomass were affected little by liming albeit

some pH related replacements between acid-tolerant and acid-sensitive species were observed (Kuoppamäki 1993a, b, II–III). In L. Mekkojärvi, the total biomass of the phytoplankton increased after the food web manipulation, whereas the species composition remained similar during the study period (V).

In the studied lakes, the phytoplankton community typically included several mixotrophic chrysophycean and prymnesiophycean species (Table 4) capable of phagotrophy (Sanders et al. 1989, H. Jones et al. 1994). Flagellated cryptomonads and the raphidophyte, *G. semen*, which migrate diurnally in the water column (e.g., Salonen et al. 1984b, Salonen & Rosenberg 2000), were also abundant in the lakes (Table 4). The role of mixotrophy and diel vertical migrations (DVM) in the nutrient dynamics of brown-water lakes is discussed in more detail in chapters 7.2 and 7.3.1.

Seasonal dynamics of plankton and phytoplankton species dominance varied between the study years in L. Ruuttanjärvi (Fig. 7 in I). In 1986, the chlorophyte *Oocystis lacustris* increased exponentially since the end of June and the species exclusively dominated algal density (24000–66000 cells ml⁻¹ in the epilimnion in July–August) and biomass during the rest of the summer. Before this in June, the desmids belonging to the genera *Closterium*, typical to humic waters (e.g., Tikkanen & Willén 1992), formed high biomasses (I). *Oocystis* abundance was not related to the mineral nutrient stoichiometry in the epilimnion (linear regression analysis after log-log transformations: $F=0.035$, $p=0.854$, $n=12$). Instead, the onset of the *Oocystis* dominance coincided with the change in the zooplankton community structure (Fig. 4). *Oocystis* abundance correlated positively with the total abundance of macrozooplankton (Cladocera + Cyclopoida; $F=42.030$, $p=0.000$, $n=12$) and negatively with rotifers ($F=21.903$, $p=0.001$, $n=12$). Hessen and Lydersen (1996) suggested that the positive relationship between

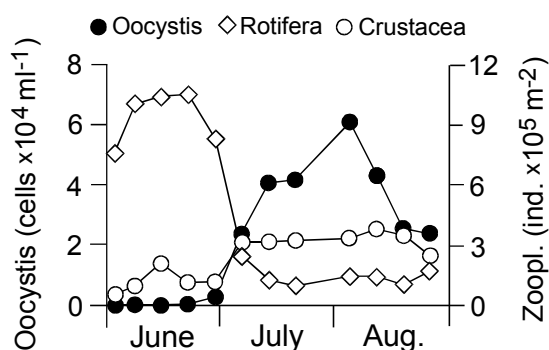

Figure 4. Cell numbers of *Oocystis lacustris* and the total abundance of rotifer and crustacean zooplankton in L. Ruuttanjärvi during the summer of 1986. Zooplankton data from paper I and Kuoppamäki (1990).

Oocystis and the cladoceran *Holopedium gibberum* in a Norwegian brown-water lake, Skjervatjern, possibly resulted from the benefit *Oocystis* derived from grazing and gut passage (Porter 1975). In the following years, *Oocystis* density was negligible in L. Ruuttanjärvi and cryptomonads were mainly dominating the phytoplankton biomass (Table 4, Fig. 7 in I). However, a strong bloom of the cyanobacteria *Anabaena circinalis* was observed in the lake in July 1987 (I). This was likely favoured by the low inorganic N:P ratio in the epilimnion (Fig. 5), because then N-fixing cyanobacteria can have a competitive advantage over other algal groups (Smith 1983). The low N:P stoichiometry of L. Ruuttanjärvi water in 1987 could be related to annual and seasonal differences in precipitation. The autumn of 1986 and the summer of 1987 were wet, which increased the loading of P from the P-fertilized catchment to the lake (M. Järvinen, unpubl.). During the year of 1987 the inlet of the lake was flowing throughout the summer, while in 1986 and 1988 it ran dry for several weeks (data not shown). This cyanobacterial bloom is just one example of how year-to-year variations in weather may modify the dynamics of plankton in lakes (e.g., Schindler et al. 1996, George et al. 2000, Gerten & Adrian 2000). In eutrophic lakes, the success of cyanobacteria has also been related to their resistance against zooplankton grazing (e.g., Gragnani et al. 1999). The role of "top-down" effects on cyanobacteria was likely small in L. Ruuttanjärvi, because the zooplankton community was always dominated by small cladocerans and rotifers in the years of 1986-1988 (I). Nevertheless, grazing by small-sized zooplankton could not prevent the biomass increases of the grazing resistant and less edible *Closterium*, *Oocystis* and *Anabaena* (e.g., Reynolds 1984, Harris 1986, Sterner 1989).

7.2 Vertical distribution of plankton

Vertical distribution of phytoplankton biomass differed between the lakes with or without planktivorous fish, which might result

from the differences in their zooplankton community structure. In lakes with no plantivorous fish (Pussijärvi and Mekkojärvi), the zooplankton community was composed of larger-sized species albeit the proportion of small-sized rotifers in the metazoan zooplankton abundance was high in L. Pussijärvi (Table 2, I, V). In these lakes, the phytoplankton biomass was low in the epilimnion, but it increased close to the thermocline and in the hypolimnion (Fig. 6, Fig. 4 in I). The lakes with planktivorous fish populations were characterised by smaller-sized zooplankton species (Table 2, I-II, K. Salonen, J. Keskitalo & A. Lehtovaara, unpubl.) and they had a more even distribution of phytoplankton biomass in the water column (Fig. 6). This suggests that in the absence of fish predation zooplankton grazing can effectively control phytoplankton biomass in the epilimnion. This is reasonable, because the zooplankton grazing rate is directly related to biomass (e.g., Peters & Downing 1984). Low phytoplankton biomass in the upper water layer of the limed side of L. Iso Valkjärvi indicates, however, that also other factors, such as light climate (Fig. 2 in II, see also below), can shape the phytoplankton biomass distribution. The role of zooplankton in shaping algal biomass is discussed in more detail in chapter 7.4 in connection with the L. Mekkojärvi fish manipulation experiment.

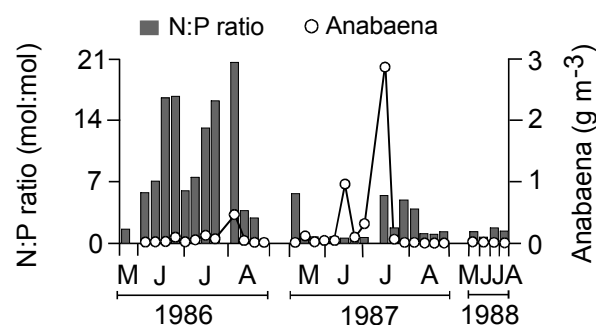

Figure 5. Biomass development of the cyanobacteria *Anabaena circinalis* and the inorganic nitrogen to phosphorus (N:P) ratio in the epilimnion of L. Ruuttanjärvi in June-August 1986-1988.

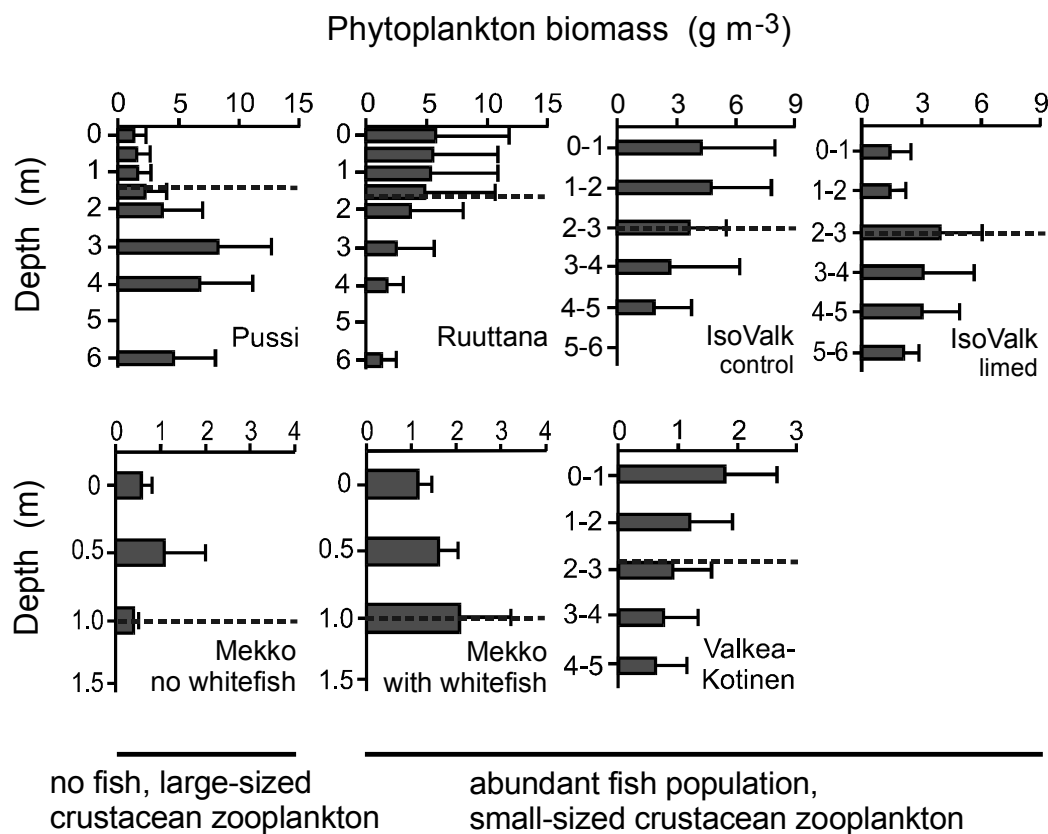

Figure 6. Mean (+standard deviation) biomass of phytoplankton at different depths in the lakes with no planktivorous fish and in lakes with abundant planktivorous fish population during June–August ($n=7-27$). Broken lines indicate the approximate position of the thermocline. Phytoplankton data of *L. Valkea-Kotinen* by A.-L. Holopainen (unpubl.).

The chlorophyte *Chlamydomonas* sp. and the prasinophyte *Scourfieldia cordiformis* were not present in the epilimnion of *L. Pussijärvi* except in early spring, but their abundance was high in the hypolimnion (I). *S. cordiformis* has a similar vertical distribution in *L. Mekkojärvi* (Arvola et al. 1992, M. Järvinen unpubl.). In the literature, *Scourfieldia* has been reported to prefer cold and humic water (e.g., Ettl 1983, Tikkanen & Willén 1992). However, the results of Salonen et al. (1992b, c) from the experiments with *L. Mekkojärvi* water suggest that the hypolimnetic occurrence of *Chlamydomonas* and *Scourfieldia* might also be related to zooplankton grazing because both species were present in 1 m³ containers with warm (10–16 °C or >20 °C) epilimnetic water if *Daphnia* were removed. *Chlamydomonas* and *Scourfieldia* may derive benefit from their stay in the hypolimnion, close or below the

compensation depth for photosynthesis, through the improved nutrient availability and reduced zooplankton grazing (Arvola et al. 1992).

The raphidophyte *G. semen* was dominating both during pre- and post-liming periods in *L. Iso Valkjärvi* (II). The diurnal vertical distribution of the species varies in lakes due to migration (e.g., Cowles & Brambel 1936). *G. semen* prefers low levels of irradiation (Sörensen 1954, Eloranta & Räike 1995), which probably explained the deeper occurrence of the species in 1992 in the limed side of *L. Iso Valkjärvi* where transparency was greater than in the control side (Fig. 2 in II). The light intensity of 75–95 $\mu\text{mol m}^{-2} \text{s}^{-1}$ can be high enough to halt the upward migration of *G. semen* (Eloranta & Räike 1995). Corresponding light intensity was measured in 1992 in the control side of *L. Iso*

Valkjärvi at the depth of ca. 2 m and in the limed side about 1 m deeper (M. Järvinen & K. Kuoppamäki, unpubl., Fig. 2 in II). Salonen and co-workers have studied the diel vertical migration of *G. semen* in L. Valkea-Kotinen (Salonen et al. 1993, Salonen & Rosenberg 2000). They suggest that the species acquires nutrients from nutrient-rich water layers by vertical migration. Such beneficial hypolimnetic nutrient retrieval by migration has also been reported for other algal species (Salonen et al. 1984b, Watanabe et al. 1991). Salonen and co-workers also hypothesised that the low concentrations of phosphate and ammonium in the anoxic hypolimnion of L. Valkea-Kotinen might result from the nutrient uptake by *G. semen* and other migrating algae (e.g., cryptomonads). The nutrient data from L. Iso Valkjärvi supports the hypothesis; despite anoxia, which should result in the release of P and N from the sediments (e.g., Wetzel 2001), the concentrations of inorganic nutrients in summer were low in the hypolimnion of the lake during the dominance of the migrating *G. semen* and cryptomonads (Fig. 7, Rask 1991, M. Järvinen & K. Kuoppamäki, unpubl.). Kopáček et al. (2000) have related the low hypolimnetic concentrations of P to low pH and a consequent Al inactivation of P in the water column and sediments in a mountain

lake, Plešné, in the Bohemian Forest, Czech Republic. It is unlikely that this would be the mechanism behind the low P concentrations in the hypolimnion of Lakes Iso Valkjärvi and Valkea-Kotinen, because the lakes are located in a region which is less affected by acid precipitation and their total Al concentrations are several-fold lower than those reported for L. Plešné (Kopáček et al. 2000). Further, in contrast to the situation in L. Plešné the concentrations of $\text{NH}_4\text{-N}$ were low in the anoxic hypolimnion of Finnish lakes which cannot be explained by metal binding. Accumulation of P and N in the hypolimnion during winter anoxia (M. Järvinen, unpubl., J. Keskitalo, unpubl., Fig. 7) when the biomass of migrating algae is negligible also suggests that migrating algae might be responsible for the low hypolimnetic nutrient concentrations in the summer, albeit the potential role of phototrophic bacteria in the upper parts of the hypolimnion cannot be overruled. The dominance of migrating phytoplankton species, such as *G. semen* and cryptomonads, in brown-water lakes suggests that DVM is an important strategy in acquiring mineral nutrients in these lakes (e.g., Salonen et al. 1984b, 1993, Jones 1991). In addition, vertical migrations to deeper water layers at night time reduce the grazing mortality of phytoplankton (Lampert 1992). DVM might

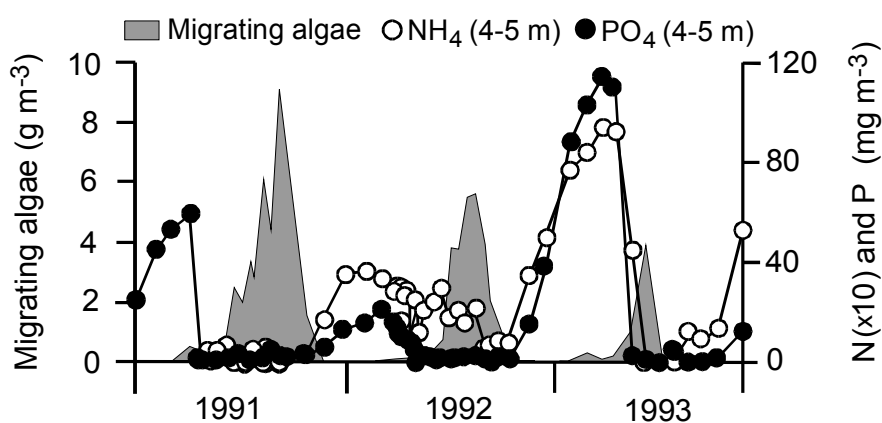

Figure 7. Concentrations of inorganic phosphorus and ammonium-nitrogen in the hypolimnion of the control side of L. Iso Valkjärvi in 1991–1993, and the total biomass of migrating algae (*Gonyostomum semen*+cryptomonads). The high nutrient concentrations during the winter of 1992–1993 resulted from the fish-kill in autumn 1992 and a consequent decomposition of fish carcasses (cf. IV, chapter 7.4).

also explain why phytoplankton do not necessarily experience *in situ* nutrient limitation in brown-water lakes (cf. V, chapter 7.3.1).

Bacterial numbers and biomass typically increase with depth in brown-water lakes with anoxic hypolimnion (e.g., Kuuppo-Leinikki & Salonen 1992). This was also observed in both sides of L. Iso Valkjärvi (M. Järvinen & K. Kuoppamäki, unpubl., III) and in L. Pussijärvi (Fig. 8 in I), whereas in L. Ruuttanjärvi bacterial numbers showed little vertical and seasonal variation (Fig. 8 in I). In L. Pussijärvi, bacterial numbers varied between the years in all depths being highest in the year of the liming (Fig. 8 in I). Since liming has been shown to have generally negligible effects on bacterioplankton (Bell & Tranvik 1993, but see also Gahnström 1995), high bacterial abundance in 1987 might result from wet weather conditions (cf. I, chapter 7.1), which likely imported "fresh" more biologically available DOM to the lake (cf. Hessen 1998). During the rainy summer of 1987, DOC concentrations of the inlet water of L. Pussijärvi were clearly higher ($22\text{--}45\text{ g}\cdot\text{m}^{-3}$; $n=11$) than in the other study years ($<22\text{ g}\cdot\text{m}^{-3}$; $n=2$). High bacterial numbers and reduced acidity might explain the increase in the density of mixotrophic chrysophycean species in the lake in the year of the liming (cf. I).

7.3 Nutrient limitation

7.3.1 Phytoplankton

Results of nutrient enrichment bioassays suggested primary production of phytoplankton to be potentially P limited before the introduction of whitefish to L. Mekkojärvi (Figs. 5–6 in V). During this period, the zooplankton community was dominated by the cladoceran *D. longispina*, which had a high P content (Salonen et al. 1994, V). It is possible that because of its C:N:P stoichiometry (V, Andersen & Hessen 1991) *Daphnia* retarded P cycling in the epilimnion of L. Mekkojärvi. Potential P

limitation decreased immediately after the disappearance of *Daphnia*, while the opposite was found for N limitation (Figs. 4–6 in V). This shift in potential nutrient limitation was in line with the concept of consumer-driven nutrient stoichiometry (Sterner 1990, Urabe 1993, Sterner & Hessen 1994, Elser & Urabe 1999).

Excretion of whitefish was probably also responsible for the relaxation of P deficiency in L. Mekkojärvi (V). In planktivore-dominated systems, excretion by young fish sometimes dominates P recycling (Carpenter et al. 1992, D.E. Schindler et al. 1993, Vanni et al. 1997). Whitefish probably contributed most to the pelagial nutrient dynamics immediately after their introduction to the lake, because then they had plenty of *Daphnia* to prey on (V). After the disappearance of *Daphnia* whitefish became resource-limited and literally stopped growing (V). Along with rotifers, which probably benefited from the reduced competition (e.g., Neill 1984, Gilbert 1988, Pace et al. 1998), protozoan zooplankton increased after the collapse of the *Daphnia* population (Fig. 11, V–VI). Because protozoans can recycle more efficiently nutrients than herbivorous macrozooplankton (Vadstein et al. 1993, Glibert 1998), their several-fold increase following the fish introduction could also contribute to the relaxation of P limitation in L. Mekkojärvi (cf. VI). Moreover, the increase in the total algal biomass (Fig. 1 in V) increased the overall need for mineral nutrients in the epilimnion of L. Mekkojärvi (V).

In L. Valkea-Kotinen, the results of the enrichment bioassays indicated potential N limitation of phytoplankton throughout the summer (Fig. 8, M. Järvinen & K. Salonen, unpubl.). This agrees with the recent results (Jansson et al. 1996) that phytoplankton primary production can be limited by N rather than P in brown-water lakes. However, the measurements of primary production 8-, 20- and 48-h after nutrient enrichments into 1-litre containers showed that nutrient limitation developed during incubations and a clear response to the added nutrients could be

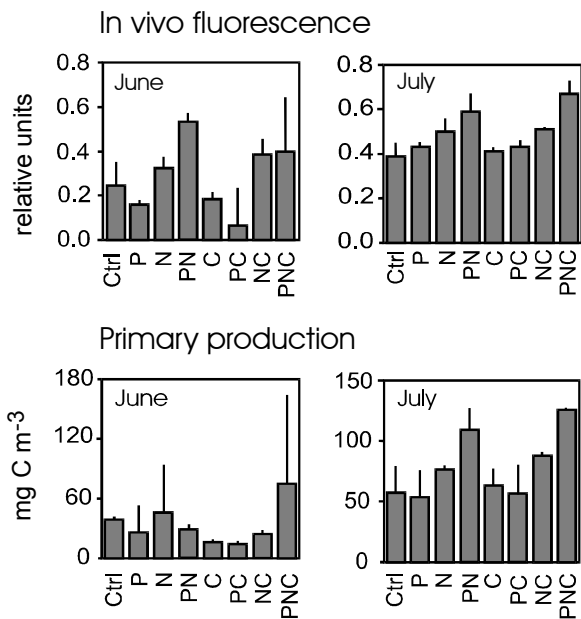

Figure 8. Mean responses (with range, $n=2$) of phytoplankton primary production (4-h incubation) and biomass (in vivo fluorescence) to nutrient enrichments in L. Valkea-Kotinen water in June and July 1996.

discerned only after 48-h incubation (Fig. 9). This and the 1-d results of L. Mekkojärvi nutrient bioassays (Fig. 4 in V) suggest that phytoplankton do not necessarily experience *in situ* nutrient limitation in brown-water lakes (cf. Jones 1990). In the summer of 1995 and 1996, when the enrichment bioassays were conducted in L. Valkea-Kotinen, phytoplankton biomass was dominated by migrating and/or mixotrophic species (Table 4, A.-L. Holopainen, unpubl.). As discussed earlier (chapter 7.2), cryptomonads and *Gonyostomum* migrate to deeper water layers of the lake during darkness; very likely to acquire nutrients (Salonen et al. 1993, Salonen & Rosenberg 2000). Luxury consumption and storage of phosphate into the cells in the hypolimnion might explain the development of N limitation during the bioassays, when the algae were restrained from migrating. This could also be an alternative explanation for the increased N limitation in L. Mekkojärvi, because the biomass of the migrating phytoplankton species increased after the disappearance of *Daphnia* in the lake (V). Another reason for the observed N limitation

of phytoplankton in L. Valkea-Kotinen could be the high numbers of mixotrophic algae (Table 4), which can acquire their needed P via phagotrophy (e.g., Nygaard & Tobiesen 1993) thus increasing the relative N deficiency (Jansson 1998). Jansson and co-workers (1996) have shown that among the phytoplankton community of a brown-water lake in northern Sweden, mixotrophic species were N limited at the same time when obligatory autotrophic species experienced P limitation. Thus, bacterivory by algae is likely an important strategy to acquire P and/or other nutrients which are in short supply (Nygaard & Tobiesen 1993, H. Jones et al. 1994, Jones 1994). Algae cannot generally compete with bacteria for available P in the epilimnion (Currie et al. 1986), and therefore several species likely compensate their nutritional demands via ingesting and digesting P-rich bacteria (Jansson 1998). In brown-water lakes, P-limitation of bacteria (Table 1, chapter 7.3.2, VI, M. Järvinen, unpubl.) and high bacterial numbers induced by high inputs of allochthonous organic matter (Hessen 1985, Tranvik 1988) probably promote this strategy to acquire nutrients for growth (Jansson et al. 1996, Jansson 1998). Potential N limitation of phytoplankton was also in line with the theory of the consumer-driven nutrient stoichiometry, because zooplankton community in L. Valkea-Kotinen was mostly composed of small-sized herbivores (Table 2) which typically have higher C:P and N:P ratios than *Daphnia* (Sterner & Hessen 1994, V).

7.3.2 Bacterioplankton

The results of enrichment bioassays with L. Mekkojärvi (VI) and L. Valkea-Kotinen water (M. Järvinen, unpubl.) agree with recent studies (Table 1) that besides labile C, P often limits bacterioplankton in brown-water lakes. Bacterioplankton production was almost exclusively limited by P in L. Valkea-Kotinen and it increased most when P additions were coupled with N additions (PN and PNC enrichments, Figs. 9–10, M. Järvinen, unpubl.). Enrichments with glucose did not

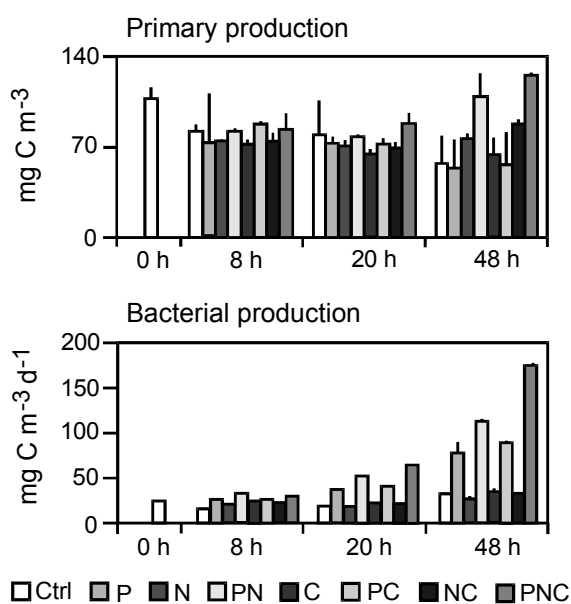

Figure 9. Responses of phytoplankton primary production (4 h incubation) and bacterioplankton production to nutrient enrichments in the beginning (0 h) of the bioassay, and 8-, 20- and 48-h after nutrient additions in *L. Valkea-Kotinen* water in 31 July–2 August 1996. Mean and range ($n=2$).

increase the bacterial production suggesting that bacteria were not C limited in *L. Valkea-Kotinen*. On the contrary, the development of plankton respiration after nutrient enrichments in *L. Mekkojärvi* water indicated potential C limitation or co-limitation of C and P by bacteria (VI). Nutrient limitation of bacterioplankton was estimated in *L. Mekkojärvi* by following changes in plankton respiration after the nutrient additions, and in *L. Valkea-Kotinen* following changes in bacterioplankton production, respectively. The difference in the potential nutrient limitation of bacterioplankton between the lakes probably did not result from the different methods used, because when the both methods were used simultaneously in the 1996 experiments in *L. Valkea-Kotinen* they produced similar results; P deficiency of bacterioplankton (data not shown, M. Järvinen unpubl.). One potential explanation for the difference in bacterial nutrient limitation between the lakes might be that *L. Valkea-Kotinen* has a higher phytoplankton

biomass and production than *L. Mekkojärvi* (Table 4, Table 1 in Arvola et al. 1999b), and accordingly there is possibly more autochthonous DOC available for bacteria in *L. Valkea-Kotinen*, which can be more readily used for bacterial growth than refractory allochthonous DOC (e.g., Tranvik 1998).

Contrary to the phytoplankton production, bacterial production increased already 8-h after the nutrient enrichments suggesting that bacteria likely experienced *in situ* P limitation in the epilimnion of *L. Valkea-Kotinen* in 1996 (Fig. 9). Bacterial cells may be insatiable with respect to P (Vadstein et al. 1993) and due to their high surface area to volume ratio, bacteria are considered superior competitors for nutrients (Currie et al. 1986). In the paper V, combined additions of P and C failed to increase phytoplankton production during 5-d in the bioassays with *L. Mekkojärvi* water (Fig. 6e in V). This also suggested that bacteria might be superior to algae in the uptake of P in the presence of a labile organic C source (V), which potentially limited bacteria in *L. Mekkojärvi* (VI). Despite the observation that bacterioplankton

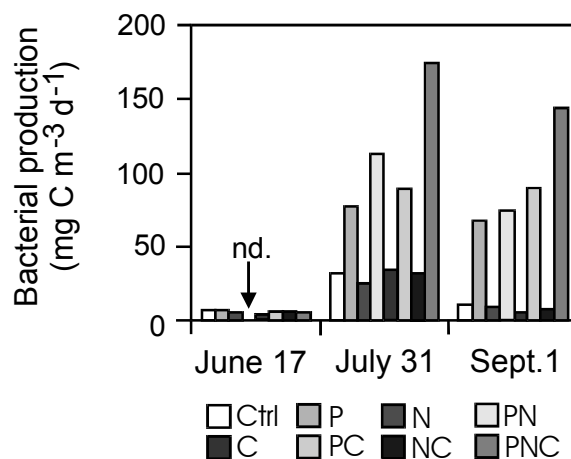

Figure 10. Responses of bacterioplankton production to nutrient enrichments 2-d after nutrient additions in *L. Valkea-Kotinen* water on June 17, July 31 and September 1, 1996. In June-July, bacterial production was measured from the mixed sample of duplicates, in September separately from the duplicates (mean and range, $n=2$).

dominates P uptake in L. Mekkojärvi (Jones 1990, Salonen et al. 1994) phytoplankton has been suggested to successfully compete with bacteria for the available P in the lake (Jones 1990). This is likely related to mixotrophy and DVM of several algal species in the lake (cf. chapters 7.2 and 7.3.1).

7.4 Grazing control of plankton

The central role of *Daphnia* in regulating phyto- and microzooplankton in L. Mekkojärvi became evident after the food web manipulation. The disappearance of *Daphnia* following the whitefish introduction was accompanied by the increase in phytoplankton (Fig. 1 & 3a in V) and protozoan biomass (Fig. 11, Fig. 10 in VI, V–VI) in the epilimnion of the lake. The changes in single-celled plankton were similar to those earlier reported in enclosure experiments with L. Mekkojärvi water after the removal of *Daphnia* (Salonen et al. 1992b, c, Arvola & Salonen 2001). The disappearance of *Daphnia*, which effectively grazes on bacteria, phytoplankton and phagotrophic flagellates (Kankaala 1998, Porter 1996), likely released rotifers and protozoan zooplankton from resource competition, and phytoplankton and protozoans from grazing control, respectively. An inverse relationship between *Daphnia* and rotifer abundance could also be found in L. Pussijärvi (I). In the control side of L. Iso Valkjärvi, predation by the increased numbers of *Chaoborus* following the fish-kill was probably responsible for the decrease in small-sized crustacean zooplankton and the increase in rotifers (IV). The biomass of phytoplankton was low in the epilimnion after the fish-kill which was mainly due to the decreased density of the large-sized *Gonyostomum semen*. This might result from the increased numbers of the cladoceran macrofiltrator *Holopedium gibberum* (IV), which has been suggested to be able to control *Gonyostomum* abundance by grazing (Salonen & Rosenberg 2000).

The importance of zooplankton regulation of phytoplankton biomass (chl-*a*) has been

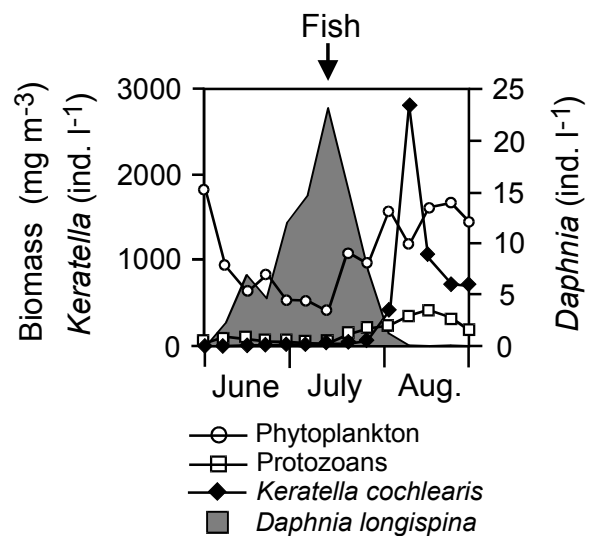

Figure 11. Densities of the cladoceran *Daphnia longispina* and the rotifer *Keratella cochlearis* in the pelagial sampling point, and the total biomass of phytoplankton and protozoan zooplankton in the epilimnion of L. Mekkojärvi in the summer of 1994. The arrow indicates the time of whitefish introduction (July 14, 1994). Modified from Fig. 1 in VI. Unpublished *Keratella* data by T. Aalto & K. Salonen and protozoan data by M. Järvinen.

shown in Swedish and Antarctic lakes by Hansson (1992). It appears that the large-sized *Daphnia* can significantly control lower trophic levels by efficient grazing in the absence of efficient predators both in clearwater and brown-water lakes. On the contrary, in lakes with three food chain levels fish predation may release phytoplankton from zooplankton grazing control (Hansson 1992, Carpenter et al. 2001). Then, according to this food chain theory (Persson et al. 1988), phytoplankton abundance is mainly influenced by "bottom-up" forces (nutrient availability). However, the "top-down" control may be limited to the uppermost trophic levels (Ramcharan et al. 1995) in aquatic ecosystems and the complex trophic interactions may strongly modify or dampen the cascading effect (Elser et al. 1995, Ramcharan et al. 1996, Currie et al. 1999, Persson 1999, Hulot et al. 2001). Differential use of habitat by fish may also affect the outcome of trophic cascades (Holopainen et al. 1992). It has been argued that the most drastic "top-down" effects can be typically

found after massive manipulations and within a short time-span after the manipulation, whereas during a longer time period systems may be more stable (Ramcharan et al. 1995). Fish introduction to L. Mekkojärvi represented this kind of massive manipulation. However, the low epilimnetic biomass of phytoplankton in the studied lakes with *Daphnia* (two-level systems; sensu Persson et al. 1988) also indirectly indicated the regulating role of zooplankton in these lakes (Fig. 6, chapter 7.2).

Although bacteria may contribute noticeably to the diet of *Daphnia* in L. Mekkojärvi (Kankaala 1988), bacterial biomass was not clearly affected by the changed food web structure in the epilimnion of the lake (M. Likolammi, unpubl.). It is probable that the simultaneous increase in rotifer and protozoan abundance compensated for the loss of the grazing pressure by *Daphnia* against bacteria. Pace et al. (1998) have also noted that potential trophic cascades can be truncated at the microbial level. Thus, based on the heterogeneity within trophic levels, potential cascading effects at community level may be compensated by resource species less vulnerable to consumption (Persson 1999). Bacterioplankton responses to the food web manipulation could be at least partly explained by the above mentioned compensatory changes, and partly by nutrients, in L. Mekkojärvi experiments (VI).

Whole-lake and smaller-scale experiments have earlier shown that *Daphnia* abundance can strongly affect microzooplankton dynamics (Salonen et al. 1992c, Pace et al. 1998). *Daphnia* typically reduces the abundance of heterotrophic flagellates and ciliates mainly via consumption and feeding-induced mortality, and that of rotifers via suppressing their resources over time (Pace et al. 1998, see also Neill 1984). In L. Iso Valkjärvi, ciliate numbers varied in both sides of the lake during the year of liming (III). The highest ciliate numbers were observed in the spring and autumn. In paper III this was related to high phytoplankton and bacterial abundance and low zooplankton numbers

during these periods, but in addition to these also the supply of fresh humus from the watershed following the snow melt in the spring and during autumn rains might be responsible (cf. Hessen 1998). Epilimnetic ciliate numbers remained unaffected after liming probably because liming did not cause noticeable changes in prey (bacterio- and phytoplankton) and predator (metazooplankton) populations (III, Kuoppamäki 1993a,b). The changes in ciliate abundance and size distribution in the control side in June–July 1991 probably resulted from higher rotifer and crustacean zooplankton abundance (III). After the fish death, the abundance of cladocerans decreased in the control side of L. Iso Valkjärvi which possibly resulted from increased invertebrate predation (IV). This had no clear effects on the ciliate numbers in the epilimnion of the lake during the summer. On the contrary, ciliate numbers increased strongly in the hypolimnion (IV). Although the massive fish kill was responsible for the changes in hypolimnetic microzooplankton, the mechanism behind the change was clearly resource-based: fish carcasses introduced high amounts of new degradable organic material to the bottom layers of the control side of the lake. This stimulated bacterial growth which in turn provided extra food for ciliates and heterotrophic flagellates. At the plankton level it was often difficult to distinguish whether the observed changes following the fish-kill (IV) were resource-based or consumer-driven.

7.5 General discussion

The studies included in the thesis provide mainly indirect evidence on resource-based and consumer-driven control in brown-water lakes, because originally they were not designed for that purpose. Also, as pointed out by Osenberg & Mittelbach (1996) "while trophic cascades clearly reveal that predators influence prey dynamics, the occurrence of trophic cascades says little about the relative importance of limitation imposed by predation vs. resources". Nevertheless, examination of

the results of papers I–VI from this point of view revealed interesting features of food-web regulation in the studied lakes. The results of nutrient enrichment bioassays suggested that despite low mineral nutrient concentrations phytoplankton was not necessarily nutrient deficient *in situ* in the epilimnion (V, and unpubl.). The results gave also support to the view that the grazer community structure can affect which nutrient becomes potentially limiting. The comparison of plankton communities between the lakes with or without planktivorous fish, and the results of the fish manipulation experiment revealed the central role of large herbivorous (omnivorous) *Daphnia* in regulating phyto- and microzooplankton in lakes devoid of planktivorous fish. In fishless brown-water lakes *Daphnia* possibly retard nutrient cycling in several ways. *Daphnia* may act as P sink due to its characteristic nutrient stoichiometry (high body P content; e.g., Sterner & Hessen 1994). *Daphnia* may reduce the efficient functioning of the microbial loop by grazing protozoan zooplankton, which are efficient nutrient recyclers (e.g., Glibert 1998). *Daphnia* may further slow down nutrient cycling by grazing small-sized edible algae which may increase the numbers of non-edible "slow-growth" algal species (e.g., Sterner 1989).

The studies presented in the thesis cover the range from small-scale bottle experiments (V–VI) to whole-lake ecosystem manipulations (I–II, V). Higher level experimental tests (enclosure or ecosystem level experiments) are more natural than culture or community culture tests, but their results can be difficult to interpret (e.g., Hecky & Kilham 1988). The experimental designs of the liming experiments in Lakes Iso Valkjärvi and Pussijärvi were strongly based on limnological monitoring with the emphasis on possible changes in the plankton community structure. Because limnology of lakes may vary strongly between the years simply due to variations in weather conditions (Kratz et al. 1998, George et al. 2000), as was seen e.g., in the phytoplankton dynamics of L. Ruuttanjärvi (I, chapter 7.1), pre-treatment

as well as post-treatment monitoring periods should be long enough in experimental manipulations. In this respect, limnological monitoring of the pre-liming period after the division of L. Iso Valkjärvi (II) was, due to logistic reasons, too limited e.g., to allow a proper statistical comparison between the lake sides (e.g., Carpenter et al. 1989). Also, the division of a lake into separate compartments may lead alone to divergence in water chemistry or biology e.g., due to altered hydrology or morphometry of the basins (Brettum 1992, Christensen et al. 1996). Winemiller & Polis (1996) state that "experimental manipulations of food webs can identify species and feeding links that most influence population and community dynamics". On the other hand, whole-lake experiments, such as the fish introduction in L. Mekkojärvi (V–VI), can seldomly be replicated. Despite this, whole-lake experiments can provide important and more realistic information on the ecosystem functioning than smaller-scale or laboratory experiments (Schindler 1990, 1998, Carpenter et al. 1995, Pace et al. 1998). Risks related to small-scale bottle-experiments were also appreciated in the nutrient enrichment bioassays of this study; isolation of phytoplankton into bottles and the prevention of their vertical migration likely strengthened potential nutrient limitation (V–VI, and unpubl. results from L. Valkea-Kotinen). An ideal in experimental tests would be of course a combination of several experimental scales during the study.

8. Conclusions

1. Liming of L. Pussijärvi and the experimental side of L. Iso Valkjärvi resulted in only minor changes in the plankton community structure. This probably resulted from the negligible changes in the nutrient concentrations and the mostly unchanged food web structure. In particular, no changes occurred at the level of key species (European perch, *Perca fluviatilis*, in L. Iso Valkjärvi).

2. Nutrient enrichment bioassays suggested phytoplankton primary production to be N limited in L. Valkea-Kotinen and after the removal of *Daphnia* also in L. Mekkojärvi. The results also suggested that phytoplankton do not necessarily experience *in situ* nutrient limitation in these lakes. This likely results from the behavioural strategies of several phytoplankton species to acquire nutrients (diel vertical migrations and mixotrophy).

3. In L. Valkea-Kotinen, phytoplankton was N limited while at the same time bacterioplankton was P limited. The affinity of bacteria to P was high.

4. Potential P limitation shifted towards N limitation in L. Mekkojärvi after the disappearance of *Daphnia longispina* which was in line with the consumer-driven nutrient stoichiometry (e.g., Elser & Urabe 1999) suggesting that zooplankton community structure may determine, via the body C:N:P ratios and excretion, the nutrient which limits algal growth.

5. The food web manipulation experiment in L. Mekkojärvi showed that in the absence of planktivory, large *Daphnia* can strongly control the abundance of its single-celled prey. Indirectly this was further supported by the low phytoplankton biomass in the epilimnion of the fishless lake, Pussijärvi. The regulating role of *Daphnia* was clearly discernible in phytoplankton, ciliates and rotifers, but less in bacterioplankton.

6. It is possible that low phytoplankton biomass in oligotrophic brown-water lakes devoid of planktivorous fish may be related, in addition to unfavourable light conditions and humus-metal-P binding properties (e.g., Jones 1992), to *Daphnia* grazing on algae, the characteristic low C:P stoichiometry of *Daphnia* which may retard epilimnetic P cycling, and to the grazing of *Daphnia* on protozoans which may reduce the nutrient recycling via the microbial loop.

9. Acknowledgements

This thesis is based on studies carried out at Lammi Biological Station of the University of Helsinki during 1986–1988 and 1990–1996.

I thank my supervisors Martti Rask, Kalevi Salonen and Lauri Arvola for sharing their wide knowledge of limnology, and in particular of the ecology of brown-water lakes, with me, and for their continuing support, caring and endurance. Masa has been my supervisor since the beginning. During the L. Iso Valkjärvi Liming Experiment (1991–1993) and its pilot study (1990) Masa showed me the principles of scientific work, and gave enough responsibility as well as freedom. I also enjoyed the relaxing informal sessions held at Masa's residence in Lakkola. I could deepen my understanding of the dynamics of brown-water lakes under the supervision of Kale during his project on "Nutrient cycling in humic lakes: light reactions, food chain structure and vertical migrations of plankton as modifiers of phosphorus cycling" in 1994–1996. Kale also showed me the importance of creative imagination and freedom from prejudice in ecosystem studies. Lauri guided me to the secrets of phytoplankton ecology during the L. Pussijärvi Liming Experiment (1986–1988; Finnish Acidification Research Programme HAPRO), and since then he has been available when various aspects of aquatic ecology and environmental change have puzzled me.

Profs. Ismo J. Holopainen and Harri Kuosa reviewed the thesis and gave valuable comments, which improved the quality of the thesis considerably. I am grateful to Diane Alarukka for correcting the language of the thesis.

I have had a pleasure to work with a set of great and dedicated colleagues. Kirsi Kuoppamäki was my inseparable partner both during L. Pussijärvi and L. Iso Valkjärvi Liming Experiments. I express my gratitude also to other members of the interdisciplinary L. Iso Valkjärvi Project: L. Arvola, K.-M. Haatainen, P. Iivonen, R. Ilola, P. Jokela, T. Järvenpää, A. Järvinen, C. Karppinen, J. Kirjavainen, H. Korhonen, M. Likolammi, O. Lintinen, E. Makkonen, J. Mannio, T. Matilainen, U. Münster, P. Nummi, K. Nyberg, S. Peuranen, P. Porvari, H. Pöysä, E. Railo, J. Raitaniemi, M. Reinikainen, J. Ruuhijärvi, R. Saxén, J. Tulonen, J. Vainionpää, M. Verta, H. Viitamäki, M. Vuorinen, P. Vuorinen and K. Wepling. During the study of nutrient cycling in humic lakes I enjoyed working with

Uwe Münster, Anssi Vähätalo, Markit Likolammi, Taavi Aalto, Visa Lindblom, Eeva Huitu and Riitta Manninen. In particular, I acknowledge Anssi and Uwe the interest they gave to my studies and numerous fruitful discussions.

I have always enjoyed working at Lammi Biological Station, my "second home". I thank the managers of the station, Jaakko Syrjämäki and Lauri Arvola, for all possible help during the years. Pertti Saaristo, Jarmo Hinkkala and Kalle Heinonen provided technical assistance whenever needed. Ilpo Hakala frequently helped me in solving problems with computers and printing. Leila Tuominen helped in solving any practical problems. Jaakko Vainionpää and Riitta Ilola have been invaluable help in chemical determinations during the years. The relaxed atmosphere of the station stimulated interesting scientific discussions as well as social events whenever possible: I thank (just to mention some) Paula Einiö, Erika Heikkinen, Roger Jones, Timo Kairesalo, Paula Kankaala, Jorma Keskitalo, Maritta Liedempohja-Ruuhijärvi, Anja Lehtovaara, Mikko Liukkonen, Tarja-Riitta Metsälä, Jaana Nurminen, Anne Ojala, Anu Peltonen, Ina Pennanen, Jarmo Saarikko, Tiu Similä and Tiina Tulonen for these sessions during coffee and lunch breaks, and other occasions. Working at Lammi has also been pleasant because of good working and accommodation facilities, excellent food and gorgeous sauna.

I thank the staff and researchers of Evo Fisheries Research Station of the Finnish Game and Fisheries Research Institute for the technical and scientific assistance during the L. Iso Valkjärvi and L. Mekkojärvi experiments. I thank Anna-Liisa Holopainen and Jorma Keskitalo for the access to the unpublished L. Valkea-Kotinen monitoring data.

I thank emeritus prof. Åke Niemi and Heikki Salemaa (†) for offering an interesting view over aquatic ecology, full support and understanding during my studies of hydrobiology, and good memories. I am grateful to Markku Viitasalo who, during his term as a professor of hydrobiology, prompted me to complete this thesis. The help of prof. Jorma Kuparinen was invaluable during the final stages of this work. I thank all the people working at the Division of Hydrobiology. In particular, I am grateful to Sandra Green, Johanna Ikävalko, Marja Koski, Maria Laamanen and Milla Rautio with whom I have shared an office

during my stay at the division. With astonishment I have followed the rapid progress of these talented women both in science and in other fields of life.

Finally, I want to thank my parents Anneli and Lasse Järvinen for full support and caring during my life. I thank my wife Tarja Rousku and children Matias and Jaakko for their love, given pleasure and patience during the different stages of this study.

10. References

- Andersen, T. & Hessen, D.O. 1991. Carbon, nitrogen, and phosphorus content of freshwater zooplankton. *Limnol. Oceanogr.* 36: 807-814.
- APHA (American Public Health Association) 1985. Standard methods for the examination of water and wastewater. American Public Health Association. Washington DC, USA.
- Appelberg, M. 1995. The impact of liming on aquatic communities. In L. Henrikson & Y.W. Brodin (eds), *Liming of acidified surface waters – a Swedish synthesis*. Springer-Verlag, Berlin Heidelberg, pp. 283-308.
- Appelberg, M., Henrikson, B.-I., Henrikson, L. & Svedäng, M. 1993. Species succession and the importance of biotic interactions within the littoral community during acidification. *Ambio* 22: 290-297.
- Arnott, S.E. & Vanni, M.J. 1993. Zooplankton assemblages in fishless bog lakes: influence of biotic and abiotic factors. *Ecology* 74: 2361-2380.
- Arvola, L. 1986. Spring phytoplankton of 54 small lakes in southern Finland. *Hydrobiologia* 137: 125-134.
- Arvola, L. & Tulonen, T. 1998. Effects of allochthonous dissolved organic matter and inorganic nutrients on the growth of bacteria and algae from a highly humic lake. *Environ. Int.* 5/6: 509-520.
- Arvola, L. & Salonen, K. 2001. Plankton community of a polyhumic lake with and without *Daphnia longispina* (Cladocera). *Hydrobiologia* 445: 141-150.
- Arvola, L., Salonen, K., Kankaala, P. & Lehtovaara, A. 1992. Vertical distributions of bacteria and algae in a steeply stratified humic lake under high grazing pressure from *Daphnia longispina*. *Hydrobiologia* 229: 253-269.
- Arvola, L., Kankaala, P., Tulonen, T. & Ojala, A. 1996. Effects of phosphorus and allochthonous humic matter enrichment on the metabolic processes and community structure of plankton in a boreal lake (Lake Pääjärvi). *Can. J. Fish. Aquat. Sci.* 53: 1646-1662.
- Arvola, L., Salonen, K. & Rask, M. 1999a. Trophic interactions. In J. Keskitalo & P. Eloranta (eds), *Limnology of humic waters*. Backhuys Publishers, Leiden, The Netherlands, pp. 265-279.
- Arvola, L., Eloranta, P., Järvinen, M., Keskitalo, J. & Holopainen, A.-L. 1999b. Phytoplankton. In J. Keskitalo & P. Eloranta (eds), *Limnology of humic waters*. Backhuys Publishers, Leiden, The Netherlands, pp. 137-171.
- Bell, R.T. & Tranvik, L. 1993. Impact of acidification and liming on the microbial ecology of lakes. *Ambio* 22: 325-330.
- Bergström, A.-K. & Jansson, M. 2000. Bacterioplankton production in humic lake Öträsket in relation to input of bacterial cells and input of allochthonous organic carbon. *Microb. Ecol.* 39: 101-115.
- Bergström, A.-K., Jansson, M., Blomqvist, P. & Drakare, S. 2001. The influence of water colour and effective light climate on mixotrophic phytoflagellates in three small dystrophic Swedish lakes. *Verh. Internat. Verein. Limnol.* 27: 1861-1865.
- Bergström, I., Heinänen, A. & Salonen, K. 1986. Comparison of acridine orange, acriflavine and bishenzimide stains for enumeration of bacteria on clear and humic waters. *Appl. Environ. Microbiol.* 51: 664-667.
- Bergström, I., Mäkelä, K. & Starr, M. (eds) 1995. *Integrated Monitoring Programme in Finland, First National Report*. Ministry of the Environment, Environmental Policy Department, Helsinki. Report 1, 138 pp. + appendices.
- Birge, E.A. & Juday, C. 1927. The organic content of the water of small lakes. *Proc. Am. Philos. Soc.* 66: 357-372.
- Bowling, L.C. 1990. Heat contents, thermal stabilities and Birgean wind work in dystrophic Tasmanian lakes and reservoirs. *Aust. J. Mar. Freshw. Res.* 41: 429-441.
- Brabrand, Å., Faafeng, B.A. & Nilssen, J.P.M. 1990. Relative importance of phosphorus supply to phytoplankton production: fish excretion versus external loading. *Can. J. Fish. Aquat. Sci.* 47: 364-372.
- Brettum, P. 1992. Variations in total volume and composition of phytoplankton in Skjervatjern 1989-91. Norwegian Institute for Water Research, NIVA, HUMOR/HUMEX Newsletter 1: 11-13.
- Brooks, J.L. & Dodson, S.I. 1965. Predation, body size, and composition of plankton. *Science* 150: 28-35.
- Carlsson, P. & Caron, D.A. 2001. Seasonal variation of phosphorus limitation of bacterial growth in a small lake. *Limnol. Oceanogr.* 46: 108-120.
- Caron, D.A. & Goldman, J.C. 1990. Nutrient regeneration by marine protozoa. In G.M. Capriulo (ed), *The ecology of marine protozoa*, Oxford University Press, New York, pp. 283-306.
- Caron, D.A., Goldman, J.C. & Dennett, M.R. 1988. Experimental demonstration of the role of bacteria and herbivorous protozoa in plankton nutrient cycles. *Hydrobiologia* 159: 27-40.

- Caron, D.A., Porter, K.G. & Sanders, R.W. 1990. Carbon, nitrogen, and phosphorus budgets for the mixotrophic phytoflagellate *Poteroochromonas malhamensis* (Chrysophyceae) during bacterial ingestion. *Limnol. Oceanogr.* 35: 433-443.
- Carpenter, S.R. & Kitchell, J.F. 1988. Consumer control of lake productivity. *BioScience* 38: 764-769.
- Carpenter, S.R., Cottingham, K.L. & Schindler, D.E. 1992. Biotic feedbacks in lake phosphorus cycles. *Trends Ecol. Evol.* 7: 332-336.
- Carpenter, S.R., Frost, T.M., Heisey, D. & Kratz, T.K. 1989. Randomized intervention analysis and the interpretation of whole-ecosystem experiments. *Ecology* 70: 1142-1152.
- Carpenter, S.R., Chisholm, S.W., Krebs, C.J., Schindler, D.W. & Wright, R.F. 1995. Ecosystem experiments. *Science* 269: 324-327.
- Carpenter, S.R., Cole, J.J., Hodgson, J.R., Kitchell, J.F., Pace, M.L., Bade, D., Cottingham, K.L., Essington, T.E., Houser, J.N. & Schindler, D.E. 2001. Trophic cascades, nutrients, and lake productivity: whole-lake experiments. *Ecol. Monogr.* 71: 163-186.
- Chow-Fraser, P. & Duthie, H.C. 1987. Response of the phytoplankton community to weekly additions of monoammonium phosphate in a dystrophic lake. *Arch. Hydrobiol.* 110: 67-82.
- Christensen, D.L., Carpenter, S.R., Cottingham, K.L., Knight, S.E., LeBouton, J.P., Schindler, D.E., Voichick, N., Cole, J.J. & Pace, M.L. 1996. Pelagic responses to changes in dissolved organic carbon following diversion of a seepage lake. *Limnol. Oceanogr.* 41: 553-559.
- Cole, J.J., Likens, G.E. & Strayer, D.L. 1984. Photosynthetically produced dissolved organic carbon: an important carbon source for planktonic bacteria. *Limnol. Oceanogr.* 27: 1080-1090.
- Cole, J.J., Findlay, S. & Pace, M. 1988. Bacterial production in fresh and saltwater ecosystems: a cross-system overview. *Mar. Ecol. Prog. Ser.* 43: 1-10.
- Cole J.J., Caraco, N.F., Kling, G.W. & Kratz, T.K. 1994. Carbon dioxide supersaturation in the surface waters of lakes. *Science* 265: 1568-1570.
- Cottingham, K.L., Carpenter, S.R. & Amand, A.L. 1998. Responses of epilimnetic phytoplankton to experimental nutrient enrichment in three small seepage lakes. *J. Plankton Res.* 20: 1889-1914.
- Coveney, M.F. & Wetzel, R.G. 1992. Effects of nutrients on specific growth rate of bacterioplankton in oligotrophic lake water cultures. *Appl. Environ. Microbiol.* 58: 150-156.
- Cowles, R.P. & Brambel, C.E. 1936. A study of the environmental conditions in a bog pond with special reference to the diurnal vertical distribution of *Gonyostomum semen*. *Biol. Bull.* 71: 286-298.
- Currie, D.J., Bentzen, E. & Kalff, J. 1986. Does algal-bacterial phosphorus partitioning vary among lakes? A comparative study of orthophosphate uptake and alkaline phosphate activity in freshwater. *Can. J. Fish. Aquat. Sci.* 43: 311-318.
- Currie, D.J., Dilworth-Christie, P. & Chapleau, F. 1999. Assessing the strength of top-down influences on plankton abundance in unmanipulated lakes. *Can. J. Fish. Aquat. Sci.* 56: 427-436.
- De Haan, H., Jones, R.I. & Salonen, K. 1990. Abiotic transformations of iron and phosphate in humic lake water, revealed by double isotope labelling and gel filtration. *Limnol. Oceanogr.* 35: 491-497.
- del Giorgio, P.A. & Peters, R.H. 1993. Balance between phytoplankton production and plankton respiration in lakes. *Can. J. Fish. Aquat. Sci.* 50: 282-289.
- del Giorgio, P.A. & Gasol, J.M. 1995. Biomass distribution in freshwater plankton communities. *Am. Nat.* 146: 135-152.
- Dougan, W.K. & Wilson, A.L. 1973. Absorptiometric determination of aluminium in treated water using the reagent catechol violet. *Tech. Papers TP 103 Medmemham.* (Water Res. Assoc.).
- Eloranta, P. 1978. Light penetration in different types of lakes in Central Finland. *Holarct. Ecol.* 1: 362-366.
- Eloranta, P. 1995. Phytoplankton of the national park lakes in central and southern Finland. *Ann. Bot. Fennici* 32: 193-209.
- Eloranta, P. 1999. Humus and water physics. *In* J. Keskitalo & P. Eloranta (eds), *Limnology of humic waters*. Backhuys Publishers, Leiden, The Netherlands, pp. 59-74.
- Eloranta, P. & R  ike, A. 1995. Light as a factor affecting the vertical distribution of *Gonyostomum semen* (Ehr.) Diesing (Raphidophyceae) in lakes. *Aqua Fennica* 25: 15-22.
- Elser, J.J. & Urabe, J. 1999. The stoichiometry of consumer-driven nutrient recycling: theory, observations, and consequences. *Ecology* 80: 735-751.
- Elser, J.J., Stabler, L.B. & Hassett, R.P. 1995a. Nutrient limitation of bacterial growth and rates of bacterivory in lakes and oceans: a comparative study. *Aquat. Microb. Ecol.* 9: 105-110.

- Elser, J.J., Luecke, C., Brett, M.T. & Goldman, C.R. 1995b. Effects of food web compensation after manipulation of rainbow trout in an oligotrophic lake. *Ecology* 76: 52-69.
- Eriksson, M.O.G., Henrikson, L., Nilsson, B.-I., Nyman, G., Oscarson, H.G., Stenson, A.E. & Larsson, K. 1980. Predator-prey relations important for the biotic changes in acidified lakes. *Ambio* 9: 248-249.
- Ettl, H. 1983. Chlorophyta I. Phytomonadina. *Süsswasserflora von Mitteleuropa* 9. 807 pp.
- Franco, D.A. & Heath, R.T. 1983. Abiotic uptake and photodependent release of phosphate from high-molecular-weight humic-iron complexes in bog lakes. *In* R.F. Christman & E. Gjessing (eds), *Aquatic and terrestrial humic materials*. Ann Arbor Sci. Publ., Ann Arbor, pp. 467-480.
- Gahnström, G. 1995. The effects of liming on microbial activity and the decomposition of organic material. *In* L. Henrikson & Y.W. Brodin (eds), *Liming of acidified surface waters – a Swedish synthesis*. Springer-Verlag, Berlin, Heidelberg, pp. 179-191.
- George, D.G., Talling, J.F. & Rigg, E. 2000. Factors influencing the temporal coherence of five lakes in the English Lake District. *Freshw. Biol.* 43: 449-462.
- Gerten, D. & Adrian, R. 2000. Climate-driven changes in spring plankton dynamics and the sensitivity of shallow polymictic lakes to the North Atlantic Oscillation. *Limnol. Oceanogr.* 45: 1058-1066.
- Gilbert, J.J. 1988. Suppression of rotifer populations by *Daphnia*: a review of the evidence, the mechanisms, and the effects on zooplankton community structure. *Limnol. Oceanogr.* 33: 1286-1303.
- Gjessing, E.T. 1976. Physical and chemical characteristics of aquatic humus. *Ann Arbor Science Publ.*, Ann Arbor MI, 120 pp.
- Gjessing, E.T. & Gjerdahl, T. 1970. Influence of ultra-violet radiation on aquatic humus. *Vatten* 2: 144-145.
- Glibert, P.M. 1998. Interactions of top-down and bottom-up control in planktonic nitrogen cycling. *Hydrobiologia* 363: 1-12.
- Gragani, A., Scheffer, M. & Rinaldi, S. 1999. Top-down control of cyanobacteria: a theoretical analysis. *Am. Nat.* 153: 59-72.
- Granéli, W., Lindell, M. & Tranvik, L. 1996. Photo-oxidative production of dissolved inorganic carbon in lakes of different humic content. *Limnol. Oceanogr.* 41: 698-706.
- Gunn, J., Keller, W., Negusanti, J., Potvin, R., Beckett, P. & Winterhalder, K. 1995. Ecosystem recovery after emission reductions: Sudbury, Canada. *Water Air Soil Pollut.* 85: 1783-1788.
- Hahn, M.W. & Hofle, M.G. 2001. Grazing of protozoa and its effect on populations of aquatic bacteria. *FEMS Microb. Ecol.* 35: 113-121.
- Hakala, I. 1971. A new model of the Kajak bottom sampler, and other improvements in the zoobenthos sampling technique. *Ann. Zool. Fennici* 8: 422-426.
- Hansson, L.-A. 1992. The role of food chain composition and nutrient availability in shaping algal biomass development. *Ecology* 73: 241-247.
- Harris, G.P. 1986. *Phytoplankton ecology: structure, function and fluctuation*. Chapman and Hall, London. 384 pp.
- Havas, M. & Rosseland, B.O. 1995. Response of zooplankton, benthos, and fish to acidification: an overview. *Water Air Soil Pollut.* 85: 51-62.
- Havas, M., Woodfine, D.G., Lutz, P., Yung, K., McIsaac, H.J. & Hutchinson, T.C. 1995. Biological recovery of two previously acidified, metal-contaminated lakes near Sudbury Ontario, Canada. *Water Air Soil Pollut.* 85: 791-796.
- Hecky, R.E. & Kilham, P. 1988. Nutrient limitation of phytoplankton in freshwater and marine environments: a review of recent evidence on the effects of enrichments. *Limnol. Oceanogr.* 33: 796-822.
- Hecky, R.E., Campbell, P. & Hendzell, L.L. 1993. The stoichiometry of carbon, nitrogen, and phosphorus in particulate matter of lakes and oceans. *Limnol. Oceanogr.* 38:709-724.
- Henrikson, L., Oscarson, H.G. & Stenson, J.A.E. 1980. Does the change of predator system contribute to the biotic development in acidified lakes? *In* D. Drabløs & A. Tollan (eds), *Ecological impact of acid precipitation*, Proc. int. conf. ecol. impact acid precip., Oslo, Norway, p. 316.
- Henrikson, L. & Brodin, Y.W. (eds) 1995a. *Liming of acidified surface waters – a Swedish synthesis*. Springer-Verlag, Berlin Heidelberg. 458 pp.
- Henrikson, L. & Brodin, Y.W. 1995b. Liming of surface waters in Sweden – a synthesis. *In* L. Henrikson & Y.W. Brodin (eds), *Liming of acidified surface waters – a Swedish synthesis*. Springer-Verlag, Berlin, Heidelberg, pp. 1-44.
- Henry, R., Hino, K., Tundisi, J.G. & Ribeiro, J.B.S. 1985. Responses of phytoplankton in Lake Jacaretinga to enrichment with nitrogen and phosphorus in concentrations similar to those of the River Solimões (Amazon, Brazil). *Arch. Hydrobiol.* 103: 453-477.

- Herrman, J. & Svensson, B.S. 1995. Resilience of macroinvertebrate communities in acidified and limed streams. *Water Air Soil Pollut.* 85: 413-418.
- Hessen, D.O. 1985. The relationship between bacterial carbon and dissolved humic compounds in oligotrophic lakes. *FEMS Microb. Ecol.* 31: 215-223.
- Hessen, D.O. 1992. Dissolved organic carbon in a humic lake: effects on bacterial production and respiration. *Hydrobiologia* 229: 115-123.
- Hessen, D.O. 1998. Food webs and carbon cycling in humic lakes. *In* D.O. Hessen & L.J. Tranvik (eds), *Aquatic humic substances: ecology and biogeochemistry*. Ecological Studies 133, Springer-Verlag, Berlin Heidelberg, pp. 285-315.
- Hessen, D.O. & Lydersen, E. 1996. The zooplankton story of humic lake Skjervatjern during whole catchment acidification. *Environ. Int.* 22: 643-652.
- Hessen, D.O. & Tranvik, L.J. (eds) 1998. *Aquatic humic substances: ecology and biogeochemistry*. Ecological Studies 133, Springer-Verlag, Berlin Heidelberg. 346 pp.
- Hessen, D.O., Nygaard, K., Salonen, K. & Vähätalo, A. 1994. The effect of substrate stoichiometry on microbial activity and carbon degradation in humic lakes. *Environ. Int.* 20: 67-76.
- Holopainen, I.J., Tonn, W.M. & Paszkowski, C.A. 1992. Effects of fish density on planktonic communities and water quality in a manipulated forest pond. *Hydrobiologia* 243/244: 311-321.
- Hoppe, H.-G. 1983. Significance of exoenzymatic activities in the ecology of brackish water: measurements by means of methylumbelliferyl-substrates. *Mar. Ecol. Prog. Ser.* 11: 299-308.
- Hrbáček, J., Draková, B., Korínek, V. & Procházková, L. 1961. Demonstration of the effects of fish stock on the species composition of zooplankton and the intensity of metabolism of the whole plankton association. *Verh. Internat. Verein. Limnol.* 14: 192-195.
- Hudson, J.J., Taylor, W.D. & Schindler, D.W. 1999. Planktonic nutrient regeneration and cycling efficiency in temperate lakes. *Nature* 400: 659-661.
- Hulot, F.D., Lacroix, G., Lescher-Moutoué, F.O. & Loreau, M. 2000. Functional diversity governs ecosystem response to nutrient enrichment. *Nature* 405: 340-344.
- Hultberg, H. & Andersson, B.I. 1982. Liming of acidified lakes: induced long-term changes. *Water Air Soil Pollut.* 18: 311-331.
- Hörnström, E., Ekström, C. & Duraini, M.O. 1984. Effects of pH and different levels of aluminium on lake plankton in the Swedish west coast area. *Rep. Inst. Freshw. Res. Drottningholm* 61: 115-127.
- Ilmavirta, V. 1983. The role of flagellated phytoplankton in chains of small brown-water lakes in southern Finland. *Ann. Bot. Fennici* 20: 187-195.
- Ilmavirta, V. 1988. Phytoflagellates and their ecology in Finnish brown-water lakes. *Hydrobiologia* 161: 255-270.
- Jansson, M. 1998. Nutrient limitation and bacteria – phytoplankton interactions in humic lakes. *In* D.O. Hessen & L.J. Tranvik (eds), *Aquatic humic substances: ecology and biogeochemistry*. Springer-Verlag, Berlin Heidelberg, pp. 177-195.
- Jansson, M., Blomqvist, P., Jonsson, A. & Bergström, A.-K. 1996. Nutrient limitation of bacterioplankton, autotrophic and mixotrophic phytoplankton and heterotrophic nanoflagellates in Lake Örträsket. *Limnol. Oceanogr.* 41: 1552-1559.
- Jansson, M., Bergström, A.-K., Blomqvist, P., Isaksson, A. & Jonsson, A. 1999. Impact of allochthonous organic carbon on microbial food web carbon dynamics and structure in Lake Örträsket. *Arch. Hydrobiol.* 144: 409-428.
- Jansson, M., Bergström, A.-K., Blomqvist, P. & Drakare, S. 2000. Allochthonous organic carbon and phytoplankton/bacterioplankton production relationships in lakes. *Ecology* 81: 3250-3255.
- Jespersen, A.-M. & Christoffersen, K. 1987. Measurements of chlorophyll-a from phytoplankton using ethanol as extraction solvent. *Arch. Hydrobiol.* 109: 445-454.
- Johannessen, M. 1980. Aluminium, a buffer in acidic waters? *In* D. Drablos & A. Tollan (eds), *Ecological impact of acid precipitation*, Proc. int. conf. ecol. impact acid precip., Oslo, Norway, pp. 222-223.
- Jones, H.L.J., Leadbeater, B.S.C. & Green, J.C. 1994. Mixotrophy in haptophytes. *In* J.C. Green & B.S.C. Leadbeater (eds), *The haptophyte algae*. Syst. Assoc. Spec. Vol. 51, Clarendon Press, Oxford, pp. 247-263
- Jones, R.I. 1990. Phosphorus transformations in the epilimnion of humic lakes: biological uptake of phosphate. *Freshw. Biol.* 23: 323-337.
- Jones, R.I. 1991. Advantages of diurnal vertical migrations to phytoplankton in sharply stratified, humic forest lakes. *Arch. Hydrobiol.* 120: 257-266.

- Jones, R.I. 1992. The influence of humic substances on lacustrine planktonic food chains. *Hydrobiologia* 229: 73-91.
- Jones, R.I. 1994. Mixotrophy in planktonic protists as a spectrum of nutritional strategies. *Mar. Microb. Food Webs* 8: 87-96.
- Jones, R.I. 1998. Phytoplankton, primary production and nutrient cycling. In D.O. Hessen & L.J. Tranvik (eds), *Aquatic humic substances: ecology and biogeochemistry*. Springer-Verlag, Berlin Heidelberg, pp. 145-175.
- Jones, R.I. & Arvola, L. 1984. Light penetration and some related characteristics in small forest lakes in southern Finland. *Verh. Internat. Verein. Limnol.* 22: 811-816.
- Jones, R.I. & Salonen, K. 1985. The importance of bacterial utilization of released phytoplankton photosynthate in two humic forest lakes in southern Finland. *Holarc. Ecol.* 8: 133-140.
- Jones, R.I., Salonen, K. & De Haan, H. 1988. Phosphorus transformations in the epilimnion of humic lakes: abiotic interactions between dissolved humic materials and phosphate. *Freshw. Biol.* 19: 357-369.
- Jones, R.I., Grey, J., Sleep, D. & Arvola, L. 1999. Stable isotope analysis of zooplankton carbon nutrition in humic lakes. *Oikos* 86: 97-104.
- Jürgens, K. & Güde, H. 1990. Incorporation and release of phosphorus by planktonic bacteria and phagotrophic flagellates. *Mar. Ecol. Prog. Ser.* 59: 271-284.
- Jürgens, K., Gasol, J.M., Massana, R. & Pedrós-Alió, C. 1994. Control of heterotrophic bacteria and protozoans by *Daphnia pulex* in the epilimnion of Lake Cisó. *Arch. Hydrobiol.* 131: 55-78.
- Järnefelt, H. 1925. Zur Limnologie einiger Gewässer Inlands. *Ann. Soc. Zool. Bot. Fenn. Vanamo* 2: 185-352.
- Järvinen, M. 1993. Immediate effects of liming on biomass and primary production of phytoplankton and community respiration of plankton in an artificially divided acidified lake. In L. Rasmussen, T. Brydges & P. Mathy (eds), *Experimental manipulations of biota and biogeochemical cycling in ecosystems*. Commission of the European Communities, *Ecosystems Research Report* 4: 321-323.
- Järvinen, M. & Rask, M. 1992. The Lake Iso Valkjärvi Liming Experiment – changes in epilimnetic water properties of L. Iso Valkjärvi following liming. *Lammi Notes* 19: 1-8.
- Järvinen, M. & Rask, M. 1996. Recovery of acidified aquatic ecosystems in Finland, northern Europe. *Proc. int. symp. on acidic deposition and its impacts*, Tsukuba, Japan, pp. 219-225.
- Järvinen, M., Iivonen, P., Kuoppamäki, K. & Rask, M. 1995. Effects of liming on physical and chemical properties of L. Iso Valkjärvi. In M. Rask & M. Järvinen (eds), *The effects of liming on the ecosystem of an acidified forest lake, The Lake Iso Valkjärvi Liming Experiment – Report of studies in 1990–1993*. Finnish Game and Fisheries Research Institute, *Kalaturkimuksia – Fiskundersökningar* 101: 11-24. (in Finnish).
- Kankaala, P. 1988. The relative importance of algae and bacteria as food for *Daphnia longispina* (Cladocera) in a polyhumic lake. *Freshw. Biol.* 19: 285-296.
- Kankaala, P., Arvola, L., Tulonen, T. & Ojala, A. 1996. Carbon budget for the pelagic food web of the euphotic zone in a boreal lake (Lake Pääjärvi). *Can. J. Fish. Aquat. Sci.* 53: 1663-1674.
- Keskitalo, J. & Eloranta, P. (eds) 1999. *Limnology of humic waters*. Backhuys Publishers, Leiden, The Netherlands. 284 pp.
- Keskitalo, J. & Salonen, K. 1994. *Manual for Integrated Monitoring – Subprogramme Hydrobiology in Lakes*. National Board of Waters and the Environment, Series B. 41 pp.
- Keskitalo, J. & Salonen, K. 1998. Fluctuations of phytoplankton production and chlorophyll concentrations in a small humic lake during six years (1990-1995). In D.G. George (ed), *Management of lakes and reservoirs during global climate change*. Kluwer Academic Publishers, The Netherlands, pp. 93-109.
- Keskitalo, J., Salonen, K. & Holopainen, A.-L. 1998. Long-term fluctuations in environmental conditions, plankton and macrophytes in a humic lake, Valkea-Kotinen. *Boreal Env. Res.* 3: 251-262.
- Kirchman, D.L. 1993. Leucine incorporation as a measure of biomass production by heterotrophic bacteria. In P.F. Kemp, B.F. Sherr, E.B. Sherr & J.J. Cole (eds), *Handbook of methods in aquatic microbial ecology*. Lewis Publishers, Boca Raton, pp. 509-512.
- Kitchell, J.F., Koonce, J.F. & Tennis, P.S. 1975. Phosphorus flux through fishes. *Verh. Internat. Verein. Limnol.* 19: 2478-2484.
- Kitchell, J.F. & Carpenter, S.R. 1993. Cascading trophic interactions. In S.R. Carpenter & J.F. Kitchell (eds), *The trophic cascade in lakes*. Cambridge University Press, Great Britain, pp. 1-14.
- Kopáček, J., Hejzlar, J., Borovec, J., Porcal, P. & Kotorová, I. 2000. Phosphorus inactivation by aluminium in the water column and sediments:

- lowering of in-lake phosphorus availability in an acidified watershed-lake ecosystem. *Limnol. Oceanogr.* 45: 212-225.
- Koroleff, F. 1983. Simultaneous oxidation of nitrogen and phosphorus compounds by persulfate. *In* K. Grasshoff, M. Eberhardt & Kremling, K. (eds), *Methods of seawater analysis*. Verlag Chemie, Weinheimer, Germany, pp. 168-169.
- Kortelainen, P. 1999a. Occurrence of humic waters. *In* J. Keskitalo & P. Eloranta (eds), *Limnology of humic waters*. Backhuys Publishers, Leiden, The Netherlands, pp. 41-57.
- Kortelainen, P. 1999b. Acidity and buffer capacity. *In* J. Keskitalo & P. Eloranta (eds), *Limnology of humic waters*. Backhuys Publishers, Leiden, The Netherlands, pp. 95-115.
- Kortelainen, P. & Mannio, J. 1990. Organic acidity in Finnish lakes. *In* P. Kauppi, P. Anttila & K. Kenttämies (eds), *Acidification in Finland*. Springer-Verlag Berlin Heidelberg, pp. 849-863.
- Kratz, T.K., Soranno, P.A., Baines, S.B., Benson, B.J., Magnuson, J.J., Frost, T.M. & Lathrop, R.C. 1998. Interannual synchronous dynamics in north temperate lakes in Wisconsin, USA. *In* D.G. George (ed), *Management of lakes and reservoirs during global climate change*. Kluwer Academic Publishers, The Netherlands, pp. 273-287.
- Kuoppamäki, K. 1990. Effects of liming on zooplankton of a small acid humic lake compared with a non-limed reference lake. M.Sc. thesis, University of Helsinki. 73 pp.
- Kuoppamäki, K. 1993a. Effects of liming on crustacean zooplankton in an acidified, artificially divided forest lake in southern Finland. *Verh. Internat. Verein. Limnol.* 25: 529-533.
- Kuoppamäki, K. 1993b. Effects of liming on the rotifer community of an acidified forest lake. *In* L. Rasmussen, T. Brydges & P. Mathy (eds), *Experimental manipulations of biota and biogeochemical cycling in ecosystems*. Commission of the European Communities, Ecosystems Research Report 4: 324-326.
- Kuoppo-Leinikki, P. & Salonen, K. 1992. Bacterioplankton in a small polyhumic lake with an anoxic hypolimnion. *Hydrobiologia* 229: 159-168.
- Lampert, W. 1992. Zooplankton vertical migrations: implications for phytoplankton-zooplankton interactions. *Arch. Hydrobiol. Beih.* 35: 69-78.
- Langenheder, S. & Jürgens, K. 2001. Regulation of bacterial biomass and community structure by metazoan and protozoan predation. *Limnol. Oceanogr.* 46: 121-134.
- Lappalainen, A., Rask, M. & Vuorinen, P.J. 1988. Acidification affects the perch, *Perca fluviatilis*, populations in small lakes of southern Finland. *Env. Biol. Fish.* 21: 231-239.
- Larsson, L.S. 1988. Liming effects on phytoplankton in Lake Gårdsjön 1982-85. *In* W. Dickson (ed), *Liming of Lake Gårdsjön, an acidified lake in SW Sweden*. Nat. Swedish Environm. Prot. Board, Report 3426: 245-280.
- Larsson, S. 1995. The effects of liming on aquatic flora. *In* L. Henrikson & Y.W. Brodin (eds), *Liming of acidified surface waters – a Swedish synthesis*. Springer-Verlag, Berlin, Heidelberg, pp. 193-220.
- Latja, R. & Salonen, K. 1978. Carbon analysis for the determination of individual biomasses of planktonic animals. *Verh. Internat. Verein. Limnol.* 20: 2556-2560.
- Le, J., Wehr, J.D. & Campbell, L. 1994. Uncoupling of bacterioplankton and phytoplankton production in fresh waters is affected by inorganic nutrient limitation. *Appl. Environ. Microbiol.* 60: 2086-2093.
- Lepistö, L. 1999. Phytoplankton assemblages reflecting the ecological status of lakes in Finland. *Monogr. Bor. Env. Res.* 16, 43 pp.
- Levine, S.N. & Schindler, D.W. 1992. Modification of the N:P ratio in lakes by in situ processes. *Limnol. Oceanogr.* 37: 917-935.
- Li-Cor 1982. Radiation measurements and instrumentation. Li-Cor Inc. Lincoln, Nebraska, USA.
- Lorenzen, C.J. 1967. Determination of chlorophyll and pheo-pigments: spectrophotometric equations. *Limnol. Oceanogr.* 12: 343-346.
- Lyche, A., Andersen, T., Christoffersen, K., Hessen, D.O., Berger Hansen, P.H. & Klynsner, A. 1996. Mesocosm tracer studies. 1. Zooplankton as sources and sinks in the pelagic phosphorus cycle of a mesotrophic lake. *Limnol. Oceanogr.* 41: 460-474.
- Lydersen, E. 1998. Humus and acidification. *In* D.O. Hessen & L.J. Tranvik (eds), *Aquatic humic substances: ecology and biogeochemistry*. Springer-Verlag, Berlin Heidelberg, pp. 63-92.
- Mackereth, F.J.H., Heron, J. & Talling, J.F. 1978. Water analysis. *Freshw. Biol. Assoc. Sci. Publ.* 36. 120 pp.
- Mannio, J. 1993. Aluminium studies of the experimental neutralization of L. Lammin Iso Valkjärvi. *In* P. Iivonen & K. Kenttämies (eds), *Experimental neutralization of freshwaters*. Finnish Environment Institute, Duplicate Series 458: 19-20. (in Finnish).

- McCauley, E. 1982. The estimation of the abundance and biomass of zooplankton in samples. *In* J.A. Downing & F.H. Rigler (eds), A manual of methods for the assessment of secondary productivity in fresh waters. IBP Handbook 17: 228-265.
- McNicol, D.K., Bendell, B.E. & Mallory, M.L. 1995. Evaluating macroinvertebrate responses to recovery from acidification in small lakes in Ontario, Canada. *Water Air Soil Pollut.* 85: 451-456.
- McQueen, D.J., Post, J.R. & Mills, E.L. 1986. Trophic relationships in freshwater pelagic ecosystems. *Can. J. Fish. Aquat. Sci.* 43: 1571-1581.
- McQueen, D.J., France, R., Post, J.R., Stewart, T.J. & Lean, D.R.S. 1989. Bottom-up and top-down impacts on freshwater pelagic community structure. *Ecol. Monogr.* 59: 289-309.
- Meili, M. 1992. Sources, concentrations and characteristics of organic matter in softwater lakes and streams of the Swedish forest region. *Hydrobiologia* 229: 23-41.
- Mittelbach, G.G., Turner, A.M., Hall, D.J., Rettig, J.E. & Osenberg, C.W. 1995. Perturbation and resilience: a long-term, whole-lake study of predator extinction and reintroduction. *Ecology* 76: 2347-2360.
- Muniz, I.P. 1991. Freshwater acidification: its effects on species and communities of freshwater microbes, plants and animals. *Proc. Royal Soc. Edinb.* 97B: 227-254.
- Murphy, J. & Riley, J.P. 1962. A modified single solution method for the determination of phosphate in natural waters. *Anal. Chim. Acta* 27: 31-36.
- Münster, U. 1999. Bioavailability of nutrients. *In* J. Keskkitalo & P. Eloranta (eds), *Limnology of humic waters*. Backhuys Publishers, Leiden, The Netherlands, pp. 77-94.
- Münster, U. & De Haan, H. 1998. The role of microbial extracellular enzymes in the transformation of dissolved organic matter in humic waters. *In* D.O. Hessen & L.J. Tranvik (eds), *Aquatic humic substances: ecology and biogeochemistry*. Springer-Verlag, Berlin Heidelberg, pp. 199-257.
- Münster, U., Einiö, P. & Nurminen, J. 1989. Evaluation of the measurements of extracellular enzyme activities in a polyhumic lake by means of studies with 4-methylumbelliferyl-substrates. *Arch. Hydrobiol.* 115: 321-337.
- Münster, U., Salonen, K. & Tulonen, T. 1999. Decomposition. *In* J. Keskkitalo & P. Eloranta (eds), *Limnology of Humic Waters*. Backhuys Publishers, Leiden, The Netherlands, pp. 225-264.
- Naulapää, A. 1972. Mean volumes of some plankton organisms found in Finland. National Board of Waters, Finland, Report 40. 40 pp. (in Finnish).
- Naumann, E. 1921. Einige Grundlinien der regionalen Limnologie. *Lunds Universit. Årsskrift N.F. Avd. 2*, 17: 1-22.
- Neill, W.E. 1984. Regulation of rotifer densities by crustacean zooplankton in an oligotrophic montane lake in British Columbia. *Oecologia* 61: 175-181.
- Nygaard, K. & Tobiesen, A. 1993. Bacterivory in algae: a survival strategy during nutrient limitation. *Limnol. Oceanogr.* 38: 273-279.
- Ojala, A., Heaney, I., Arvola, L. & Barbosa, F. 1996. Growth of migrating and non-migrating cryptophytes in thermally and chemically stratified experimental columns. *Freshw. Biol.* 35: 599-608.
- Osenberg, C.W. & Mittelbach, G.G. 1996. The relative importance of resource limitation and predator limitation in food chains. *In* G.A. Polis & K.O. Winemiller (eds), *Food webs: integration of patterns and dynamics*. Chapman and Hall, New York, pp. 134-148.
- Pace, M.L., Cole, J.J. & Carpenter, S.R. 1998. Trophic cascades and compensation: differential responses of microzooplankton in whole-lake experiments. *Ecology* 79: 138-152.
- Pedros-Alió, C., Calderon-Paz, J.I. & Gasol, J.M. 2000. Comparative analysis shows that bacterivory, not viral lysis, controls the abundance of heterotrophic prokaryotic plankton. *FEMS Microb. Ecol.* 32: 157-165.
- Pennanen, V. & Frisk, T. 1984. A statistical model for conversion of absorbance measurements with significant iron interference into organic carbon in a polyhumic lake. *Aqua Fennica* 14: 171-178.
- Pernthaler, J., Sattler, B., Šimek, K., Schwarzenberger, A. & Psenner, R. 1996. Top-down effects on the size-biomass distribution of a freshwater bacterioplankton community. *Aquat. Microb. Ecol.* 10: 255-263.
- Persson, L., Andersson, G., Hamrin, S.F. & Johansson, L. 1988. Predator regulation and primary production along the productivity gradient of temperate lake ecosystems. *In* S.R. Carpenter (ed), *Complex trophic interactions in lake communities*, Springer-Verlag, New York, pp. 45-68.
- Persson, L., Bengtsson, J., Menge, B.A. & Power, M.E. 1996. Productivity and consumer regulation

- concepts, patterns, and mechanisms. *In* G.A. Polis & K.O. Winemiller (eds), *Food webs: integration of patterns and dynamics*. Chapman and Hall, New York, pp. 396-434.
- Persson, L. 1999. Trophic cascades: abiding heterogeneity and the trophic level concept at the end of the road. *Oikos* 85: 385-397.
- Peters, R.H. & Downing, J.A. 1984. Empirical analysis of zooplankton filtering and feeding rates. *Limnol. Oceanogr.* 29: 763-784.
- Polis, G.A., Holt, R.D., Menge, B.A. & Winemiller, K.O. 1996. Time, space, and life history: influences on food webs. *In* G.A. Polis & K.O. Winemiller (eds), *Food webs: integration of patterns and dynamics*. Chapman and Hall, New York, pp. 435-460.
- Porter, K.G. 1975. Viable gut passage of gelatinous green algae ingested by *Daphnia*. *Verh. Internat. Verein. Limnol.* 19: 2840-2850.
- Porter, K.G. 1996. Integrating the microbial loop and the classic food chain into a realistic planktonic food web. *In* G.A. Polis & K.O. Winemiller (eds), *Food webs: integration of patterns and dynamics*. Chapman and Hall, New York, pp. 51-59.
- Porter, K.G., Sherr, E.B., Sherr, F., Pace, M.L. & Sanders, R.W. 1985. Protozoa in planktonic food webs. *J. Protozool.* 32: 409-415.
- Post, D.M., Pace, M.L., & Hairston, N.G. Jr. 2000. Ecosystem size determines food-chain length in lakes. *Nature* 405: 1047-1049.
- Prepas, E. 1978. Sugar-frosted *Daphnia*: an improved fixation technique for Cladocera. *Limnol. Oceanogr.* 23: 557-559.
- Pöysä, H., Rask, M. & Nummi, P. 1994. Acidification and ecological interactions at higher trophic levels in small forest lakes: the perch and the common goldeneye. *Ann. Zool. Fennici* 31: 397-404.
- Raddum, G.G., Hobæk, A., Lømsland, E.R. & Johnsen, T. 1980. Phytoplankton and zooplankton in acidified lakes in South Norway. *In* D. Drabløs & A. Tollan (eds), *Ecological impact of acid precipitation*, Proc. Int. conf. ecol. impact acid precip., Oslo, Norway, pp. 332-333.
- Ramcharan, C.W., McQueen, D.J., Demers, E., Popiel, S.A., Rocchi, A.M., Yan, N.D., Wong, A.H. & Hughes, K.D. 1995. A comparative approach to determining the role of fish predation in structuring limnetic ecosystems. *Arch. Hydrobiol.* 133: 389-416.
- Ramcharan, C.W., France, R.L. & McQueen, D.J. 1996. Multiple effects of planktivorous fish on algae through a pelagic trophic cascade. *Can. J. Fish. Aquat. Sci.* 53: 2819-2828.
- Rask, M. 1991. Iso Valkjärvi research – an introduction to a multidisciplinary lake liming study. *Finnish Fish. Res.* 12: 25-34.
- Rask, M., Arvola, L. & Salonen, K. 1993. Effects of catchment deforestation and burning on the limnology of a small forest lake in southern Finland. *Verh. Internat. Verein. Limnol.* 25: 525-528.
- Rask, M., Holopainen, A.-L., Karusalmi, A., Niinioja, R., Tammi, J., Arvola, L., Keskitalo, J., Blomqvist, I., Heinimaa, S., Karppinen, C., Salonen, K. & Sarvala, J. 1998. An introduction to the limnology of the Finnish Integrated Monitoring lakes. *Boreal Env. Res.* 3: 263-274.
- Rask, M., Viljanen, M. & Sarvala, J. 1999. Humic lakes as fish habitats. *In* J. Keskitalo & P. Eloranta (eds), *Limnology of humic waters*. Backhuys Publishers, Leiden, The Netherlands, pp. 209-224.
- Reinertsen, H., Jensen, A., Koksvik, J.I., Langeland, A. & Olsen, Y. 1990. Effects of fish removal on the limnetic ecosystem of a eutrophic lake. *Can. J. Fish Aquat. Sci.* 47: 166-173.
- Reuss, J.O., Cosby, B.J. & Wright, R.F. 1987. Chemical processes governing soil and water acidification. *Nature* 329: 27-32.
- Reynolds, C.S. 1984. *The ecology of freshwater phytoplankton*. Cambridge University Press, Cambridge, 384 pp.
- Rodhe, H., Grennfelt, P., Wisniewski, J., Ågren, C., Bengtsson, G., Johansson, K., Kauppi, P., Kucera, V., Rasmussen, L., Rosseland, B., Schotte, L. & Selldén, G. 1995. Acid Reign '95? – conference summary statement. *Water Air Soil Pollut.* 85: 1-14.
- Rosseland, B.O., Blakar, I.A., Bulger, A., Krokklund, F., Kvellstad, A., Lydersen, E., Oughton, D.H., Salbu, B., Staurnes, M. & Vogt, R. 1992. The mixing zone between limed and acidic river waters: complex aluminium chemistry and extreme toxicity for salmonids. *Environ. Pollut.* 78: 3-8.
- Salonen, K. 1979. A versatile method for rapid and accurate determination of carbon by high temperature combustion. *Limnol. Oceanogr.* 24: 177-183.
- Salonen, K. 1981. Rapid and precise determination of total inorganic carbon and some gases in aqueous solutions. *Wat. Res.* 15: 403-406.
- Salonen, K. & Hammar, T. 1986. On the importance of dissolved organic matter in the nutrition of zooplankton in some lake waters. *Oecologia* 68: 246-253.
- Salonen, K. & Jokinen, S. 1988. Flagellate grazing on bacteria in a small dystrophic lake. *Hydrobiologia* 161: 203-209.

- Salonen, K. & Lehtovaara, A. 1992. Migrations of haemoglobin-rich *Daphnia longispina* in a small, steeply stratified, humic lake with an anoxic hypolimnion. *Hydrobiologia* 229: 271-288.
- Salonen, K. & Rosenberg, M. 2000. Advantages from diel vertical migration can explain the dominance of *Gonyostomum semen* (Raphidophyceae) in a small, steeply-stratified lake. *J. Plankton Res.* 22: 1841-1853.
- Salonen, K., Kononen, K. & Arvola, L. 1983. Respiration of plankton in two small, polymictic lakes. *Hydrobiologia* 101: 65-70.
- Salonen, K., Arvola, L. & Rask, M. 1984a. Autumnal and vernal circulation of small forest lakes in Southern Finland. *Verh. Internat. Verein. Limnol.* 22: 103-107.
- Salonen, K., Jones, R.I. & Arvola, L. 1984b. Hypolimnetic phosphorus retrieval by diel vertical migrations of lake phytoplankton. *Freshw. Biol.* 14: 431-438.
- Salonen, K., Kairesalo, T. & Jones, R.I. (eds) 1992a. Dissolved organic matter in lacustrine ecosystems: energy source and system regulator. *Dev. Hydrobiol.* 73. 291 pp.
- Salonen, K., Arvola, L., Tulonen, T., Hammar, T., Metsälä, T.-R., Kankaala, P. & Münster, U. 1992b. Planktonic food chains of a highly humic lake. I. A mesocosm experiment during the spring primary production maximum. *Hydrobiologia* 229: 125-142.
- Salonen, K., Kankaala, P., Tulonen, T., Hammar, T., James, M., Metsälä, T.-R. & Arvola, L. 1992c. Planktonic food chains of a highly humic lake. II. A mesocosm experiment in summer during dominance of heterotrophic processes. *Hydrobiologia* 229: 143-157.
- Salonen, K., Arvola, L. & Rosenberg, M. 1993. Diel vertical migrations of phyto- and zooplankton in a small steeply stratified humic lake with low nutrient concentration. *Verh. Internat. Verein. Limnol.* 25: 539-543.
- Salonen, K., Jones, R.I., De Haan, H. & James, M. 1994. Radiotracer study of phosphorus uptake by plankton and redistribution in the water column of a small humic lake. *Limnol. Oceanogr.* 39: 69-83.
- Sampson, C.J., Brezonik, P.L., Frost, T.M., Webster, K.E. & Simonsen, T.D. 1995. Experimental acidification of Little Rock Lake, Wisconsin: the first four years of chemical and biological recovery. *Water Air Soil Pollut.* 85: 1713-1719.
- Sanders, R.W., Porter, K.G., Bennett, S.J. & DeBiase, A.E. 1989. Seasonal patterns of bacterivory by flagellates, ciliates, rotifers and cladocerans in a freshwater planktonic community. *Limnol. Oceanogr.* 17: 327-340.
- Sarvala, J. & Halsinaho, S. 1990. Crustacean zooplankton of Finnish forest lakes in relation to acidity and other environmental factors. *In* P. Kauppi, P. Anttila & K. Kenttämies (eds), *Acidification in Finland*. Springer-Verlag, Berlin Heidelberg, pp. 1009-1027.
- Sarvala, J., Kankaala, P., Zingel, P. & Arvola, L. 1999. Zooplankton. *In* J. Keskkitalo & P. Eloranta (eds), *Limnology of humic waters*. Backhuys Publishers, Leiden, The Netherlands, pp. 173-191.
- Saunders, P.A., Shaw, W.H. & Bukaveckas, P.A. 2000. Differences in nutrient limitation and grazer suppression of phytoplankton in seepage and drainage lakes of the Adirondack region, NY, U.S.A. *Freshw. Biol.* 43: 391-407.
- Schindler, D.E., Kitchell, J.F., He X., Carpenter, S.R., Hodgson, J.R. & Cottingham, K.L. 1993. Food web structure and phosphorus cycling in lakes. *Trans. Am. Fish. Soc.* 122: 756-772.
- Schindler, D.W. 1977. Evolution of phosphorus limitation in lakes. *Science* 195: 260-262.
- Schindler, D.W. 1990. Experimental perturbations of whole lakes as tests of hypotheses concerning ecosystem structure and function. *Oikos* 57: 25-41.
- Schindler, D.W. 1998. Replication versus realism: the necessity for ecosystem-scale experiments, replicated or not. *Ecosystems* 1: 323-334.
- Schindler, D.W., Schmidt, R.V. & Reid, R.A. 1972a. Acidification and bubbling as an alternative to filtration in determining phytoplankton production by the ¹⁴C method. *J. Fish. Res. Board Can.* 29: 1627-1631.
- Schindler, D.W., Brunskill, G.J., Emerson, S., Broecker, W.S. & Peng, T.-H. 1972b. Atmospheric carbon dioxide: its role in maintaining phytoplankton standing crops. *Science* 177: 1192-1194.
- Schindler, D.W., Frost, T.M., Mills, K.H., Chang, P.S.S., Davies, I.J., Findlay, L., Malley, D.F., Shearer, J.A., Turner, M.A., Garrison, P.J., Watras, C.J., Webster, K., Gunn, J.M., Brezonik, P.L. & Swenson, W.A. 1991. Comparisons between experimentally- and atmospherically-acidified lakes during stress and recovery. *Proc. Royal Soc. Edinb.* 97B: 193-226.
- Schindler, D.W., Bayley, S.E., Parker, B.R., Beaty, K.G., Cruikshank, D.R., Fee, E.J., Schindler, E.U. & Stainton, M.P. 1996. The effects of climatic warming on the properties of boreal lakes and streams at the Experimental Lakes Area, northwestern Ontario. *Limnol. Oceanogr.* 41: 1004-1017.

- Sherr, E.B. & Sherr, B.F. 1987. High rates of consumption of bacteria by pelagic ciliates. *Nature* 325: 710-711.
- Simon, M., Cho, B.C. & Azam, F. 1992. Significance of bacterial biomass in lakes and the ocean: comparison to phytoplankton biomass and biogeochemical implications. *Mar. Ecol. Prog. Ser.* 86: 103-110.
- Skeffington, R.A. 1992. Soil/water acidification and the potential for reversibility. In G. Howells & T.R.K. Dalziel (eds), *Restoring acid waters: Loch Fleet 1984-1990*. Elsevier Appl. Sci., London, pp. 23-37.
- Skeffington R.A. & Brown, D.J.A. 1992. Timescales of recovery from acidification: implications of current knowledge for aquatic organisms. *Environ. Pollut.* 77: 227-234.
- Smith, V.H. 1983. Low nitrogen to phosphorus ratios favor dominance by blue-green algae in lake phytoplankton. *Science* 221: 669-671.
- Solórzano, L. 1969. Determination of ammonia in natural waters by the phenylhypoclorite method. *Limnol. Oceanogr.* 14: 799-801.
- Sommer, U. 1989. The role of competition for resources in phytoplankton succession. In U. Sommer (ed), *Plankton ecology: succession in plankton communities*. Springer-Verlag, Berlin Heidelberg, pp. 57-106.
- Sorokin, Y.I. 1972. Biological productivity of the Rybinsk reservoir. In Kajak, Z. & Hillbricht-Ilkowska, A. (eds), *Productivity problems of freshwaters in Krakow*, pp. 493-503.
- Stenson, J.A.E., Bohlin, T., Henrikson, L., Nilsson, B.I., Nyman, H.G., Oscarson, H.G. & Larsson, P. 1978. Effects of fish removal from a small lake. *Verh. Internat. Verein. Limnol.* 20: 794-801.
- Sterner, R.W. 1989. The role of grazers in phytoplankton succession. In U. Sommer (ed), *Plankton ecology: succession in plankton communities*. Springer-Verlag, Berlin Heidelberg, pp. 107-170.
- Sterner, R.W. 1990. The ratio of nitrogen to phosphorus resupplied by herbivores: zooplankton and the algal competitive arena. *Am. Nat.* 136: 209-229.
- Sterner, R.W. & Hessen, D.O. 1994. Algal nutrient limitation and the nutrition of aquatic herbivores. *Annu. Rev. Ecol. Syst.* 25:1-29.
- Sterner, R.W., Elser, J.J., Fee, E.J., Guilford, S.J. & Chrzanowski, T.H. 1997. The light:nutrient ratio in lakes: the balance of energy and materials affects ecosystem structure and process. *Am. Nat.* 150: 663-684.
- Sterner, R.W., Clasen, J., Lampert, W. & Weisse, T. 1998. Carbon:phosphorus stoichiometry and food chain production. *Ecol. Lett.* 1: 146-150.
- Stewart, A.J. & Wetzel, R.G. 1986. Cryptophytes and other microflagellates as couplers in planktonic community studies. *Arch. Hydrobiol.* 106: 1-19.
- Stoddard, J.L., Jeffries, D.S., Lükeville, A., Clair, T.A., Dillon, P.J., Driscoll, C.T., Forsius, M., Johannessen, M., Kahl, J.S., Kellogg J.H., Kemp, A., Mannio, J., Monteith, D.T., Murdoch, P.S., Patrick, S., Rebsdorf, A., Skjelvåle, B.L., Stainton, M.P., Traaen, T., van Dam, H., Webster, K.E., Wieting, J. & Wilander, A. 1999. Regional trends in aquatic recovery from acidification in North America and Europe. *Nature* 401: 575-578.
- Thienemann, A. 1925. *Die Binnengewässer Mitteleuropas*. *Binnengewässer* 1: 1-255.
- Tikkanen, T. & Willén, T. 1992. *Phytoplankton guide*. Naturvårdsverket, Tunn-Tryck AB, Eskilstuna, Sweden. 280 pp. (in Swedish).
- Tranvik, L.J. 1988. Availability of dissolved organic carbon for planktonic bacteria in oligotrophic lakes of differing humic content. *Microb. Ecol.* 16: 311-322.
- Tranvik, L.J. 1990. Bacterioplankton growth on fractions of dissolved organic carbon of different molecular weights from humic and clear waters. *Appl. Environ. Microbiol.* 56: 1672-1677.
- Tranvik, L.J. 1992. Allochthonous dissolved organic matter as an energy source for pelagic bacteria and the concept of the microbial loop. *Hydrobiologia* 229: 107-114.
- Tranvik, L.J. 1998. Degradation of dissolved organic matter in humic waters by bacteria. In D.O. Hessen & L.J. Tranvik (eds), *Aquatic humic substances: ecology and biogeochemistry*, Springer-Verlag Berlin Heidelberg, pp. 259-283.
- Tulonen, T. 1993. Bacterial production in a mesohumic lake estimated from [¹⁴C]leucine incorporation rate. *Microb. Ecol.* 26: 201-217.
- Tulonen, T., Salonen, K. & Arvola, L. 1992. Effects of different molecular weight fractions of dissolved organic matter on the growth of bacteria, algae and protozoa from a highly humic lake. *Hydrobiologia* 229: 239-252.
- Tulonen, T., Kankaala, P., Arvola, L. & Ojala, A. 2000. Growth and production of bacterioplankton in a deep mesohumic boreal lake. *Arch. Hydrobiol.* 147: 311-325.
- Urabe, J. 1993. N and P cycling coupled by grazer's activities: food quality and nutrient release by zooplankton. *Ecology* 74: 2337-2350.

- Utermöhl, H. 1958. Zur Vervollkommnung der quantitativen Phytoplankton-Methodik. Mitt. Internat. Verein. Limnol. 9: 1-38.
- Vadstein, O., Olsen, Y. & Reinartsen, H. 1993. The role of planktonic bacteria in phosphorus cycling in lakes – sink and link. Limnol. Oceanogr. 38: 1539-1544.
- Vadstein, O., Brekke, O., Andersen, T. & Olsen, Y. 1995. Estimation of phosphorus release rates from natural zooplankton communities feeding on planktonic algae and bacteria. Limnol. Oceanogr. 40: 250-262.
- Vanni, M.J. 1996. Nutrient transport and recycling by consumers in lake food webs: implications for algal communities. In G.A. Polis & K.O. Winemiller (eds), Food webs: integration of patterns and dynamics. Chapman and Hall, New York, pp. 81-95.
- Vanni, M.J. & Layne, C.D. 1997. Nutrient recycling and herbivory as mechanisms in the “top-down” effect of fish on algae in lakes. Ecology 78: 21-40.
- Vanni, M.J., Luecke, C., Kitchell, J.F., Allen, Y., Temte, J. & Magnuson, J.J. 1990. Effects on lower trophic levels of massive fish mortality. Nature 344: 333-335.
- Vanni, M.J., Layne, C.D. & Arnott, S.E. 1997. “Top-down” trophic interactions in lakes: effects of fish on nutrient dynamics. Ecology 78: 1-20.
- Vähätalo, A.V., Salkinoja-Salonen, M., Taalas, P. & Salonen, K. 2000. Spectrum of the quantum yield for photochemical mineralization of dissolved organic carbon in a humic lake. Limnol. Oceanogr. 45: 664-676.
- Vähätalo, A.V., Salonen, K., Münster, U., Järvinen, M. & Wetzel, R.G. 2002. Photochemical transformation of allochthonous organic matter provides bioavailable nutrients in a humic lake. Ecology (in press).
- Watanabe, M., Kohata, K. & Kimura, T. 1991. Diel vertical migration and nocturnal uptake of nutrients by *Chattonella antiqua* under stable stratification. Limnol. Oceanogr. 36: 593-602.
- Webster, K.E., Frost, T.M., Watras, C.J., Swenson, W.A., Gonzalez, M. & Garrison, P.J. 1992. Complex biological responses to the experimental acidification of Little Rock Lake, Wisconsin, USA. Environ. Pollut. 78: 73-78.
- Weppling, K., Järvinen, M. & Rask, M. 1992. The Lake Iso Valkjärvi Project – Ecological studies of liming on an artificially divided lake in southern Finland. Mitt. Hydrograph. Dienstes in Österreich 67: 62-75.
- Wetzel, R.G. 2001. Limnology – lake and river ecosystems. 3rd edition. Academic Press, California, 1006 pp.
- Wetzel, R.G. & Likens, G.E. 1991. Limnological analysis, W.B. Saunders, Philadelphia, 2nd ed. 391 pp.
- Willén, E., Pejler, Y. & Tirén, M. 1985. Räkningförfarande av växtplankton vid laboratoriet för miljökontroll, Uppsala – Laboratoriehandedning, 55 pp. (in Swedish).
- Willén, T. & Tikkanen, T. 1992. Växtplanktonflora (Phytoplankton flora; in Swedish). Naturvårdsverket, Solna, 280 pp.
- Winemiller, K.O. & Polis, G.A. 1996. Food webs: what do they tell us about the world? In G.A. Polis & K.O. Winemiller (eds), Food webs: integration of patterns and dynamics. Chapman and Hall, New York, pp. 1-22.
- Wood, E.D., Armstrong, F.A.J. & Richards, F.A. 1967. Determination of nitrate in sea water by cadmium-copper reduction to nitrite. J. Mar. Biol. Assoc. UK 47: 23-31.