



<https://helda.helsinki.fi>

Helda

Effects of extrusion process variables on the physical properties of oat containing extrudates

Alam, Syed Ariful

2012-05-15

Alam, S A 2012, 'Effects of extrusion process variables on the physical properties of oat containing extrudates', Helsinki. <

<https://helda.helsinki.fi/bitstream/handle/10138/153949/effectso.pdf?sequence=1> >

<http://hdl.handle.net/10138/229418>

acceptedVersion

Downloaded from Helda, University of Helsinki institutional repository.

This is an electronic reprint of the original article.

This reprint may differ from the original in pagination and typographic detail.

Please cite the original version.

ISSN 0355-1180

UNIVERSITY OF HELSINKI

Department of Food and Environmental Sciences

EKT Series 1548

**Effects of extrusion process variables on the physical properties
of oat-containing extrudates**

Syed Ariful Alam

Helsinki 2012

HELSINGIN YLIOPISTO — HELSINGFORS UNIVERSITET — UNIVERSITY OF HELSINKI

Tiedekunta/Osasto — Fakultet/Sektion — Faculty Faculty of Agriculture and Forestry		Laitos — Institution — Department Department of Food and Environmental Sciences	
Tekijä — Författare — Author Syed Ariful Alam			
Työn nimi — Arbetets titel — Title Effects of extrusion process variables on the physical properties of oat-containing extrudates			
Oppiaine — Läroämne — Subject Food Sciences (Major in Food Bioprocessing)			
Työn laji — Arbetets art — Level M. Sc. Thesis		Aika — Datum — Month and year May 2012	Sivumäärä — Sidoantal — Number of pages 77
Tiivistelmä — Referat — Abstract <p>Oats are a good source of protein and dietary fibre, especially β-glucan. Due to the health benefits of β-glucan, oats have gained popularity in snack food formulations. The literature review deals with oats and its components, removal of lipids and fractionation of oat products. The particular emphasis of the literature review was given to studies on the effects of different oat fractions and extrusion process variables on the properties of oat-containing extrudates. The aim of this study was to find out how different oat fractions and extrusion process variables (screw speed, water content and feed rate) affect the physical and chemical properties of the extrudates. The measured physical properties were expansion, hardness and water content.</p> <p>Extrusion trials were carried out by using defatted oat endosperm flour (EF) as the main ingredient. Whole grain oat flour (WF) was used as a reference. To improve the nutritional quality, defatted oat protein concentrate (PC) and defatted oat bran concentrate (OBC) were added to EF. The oat fractions were defatted by supercritical carbon dioxide (SC-CO₂). Pregelatinised corn starch (CS) and waxy corn starch (WS) were added in some trials to increase the expansion of the extrudates. A co-rotating twin-screw extruder was used for the extrusion. Different process variables were: water content of the mass (16, 18 and 20%), screw speed (240, 370 and 500 rpm) and feed rate (68, 76 and 84 g/min). The temperature profile of the extruder barrel was held constant in all of the trials: 40, 70, 70, 100, 110, 130 and 130 °C (sections 1–6 and die).</p> <p>Screw speed had significant effect on the expansion and hardness. Expansion increased and hardness decreased with increasing screw speed. Water content of the mass affected all the response variables in WF extrudates and all but not hardness and torque in EF extrudates. Increased water content of mass decreased the expansion and hardness in WF extrudates. Feed rate did not have significant effect on the physical properties. When using EF, more expanded and less hard extrudates compared to the WF were obtained. Addition of PC or OBC (10%) decreased the expansion and increased the hardness. Mixing of EF with corn starch (CS or WS; 30%) gave less hard and more expanded extrudates compared to pure EF. The highest expansion was achieved by the addition of WS. Even addition of OBC (20%) in a presence of WS (30%) gave highly expanded and less hard extrudates with high β-glucan content 7.4% (dry weight). Decreasing the particle size of OBC (by ultra-fine milling) or the molecular weight of β-glucan (by enzymatic hydrolysis) did not affect the physical properties of the extrudates even though small decrease in hardness was observed in the trial with enzyme-hydrolysed OBC. The results showed that defatted oat fractions can successfully be used in extrusion when mixed with corn starch. Screw speed had the most profound effect on the physical properties of the oat-containing extrudates followed by the water content of mass.</p>			
Avainsanat — Nyckelord — Keywords Beta-glucan, extrusion, defatted oats, dietary fibre			
Säilytyspaikka — Förvaringsställe — Where deposited The Digital Repository of University of Helsinki, Helda			
Muita tietoja — Övriga uppgifter — Further information EKT Series 1548			

PREFACE

First of all I would like to express my heartfelt gratitude and sincerest appreciation to my supervisor Dr. Kirsi Jouppila, University Lecturer of the Department of Food and Environmental Sciences, University of Helsinki. Her meticulous supervision, continuous guidance, intimate co-operation, encouragement and comments on the draft were significantly crucial for successful completion of my thesis. Without her guidance and advice it would not be possible to complete my thesis.

Very special and sincere thanks go to Satu Kirjoranta, Doctoral student of the University of Helsinki and Juhani Sibakov, Research Scientist and Doctoral student of VTT, for their guidance, encouragement and comments on my work. Without their assistance and co-operation many of the lab analyses and calculations could not have been done. I am also deeply indebted to Dr. Kaisa Poutanen, Professor of VTT and Dr. Nesli Sozer, Research Scientist of VTT for the fruitful discussion on my thesis topic and comments on the thesis draft, which were also important to accomplish the present study.

This study was carried out in 2011 (January–December) at the department of Food and Environmental Sciences, University of Helsinki, Finland in cooperation with VTT Technical Research Center of Finland. Thanks to VTT for providing the raw materials and Roquette, France for providing free starch samples for the experimental work to be done.

Finally, I would like to express my deepest cordial thanks to my family for their spiritual and economic support, which was very crucial for the successful completion of my master's thesis.

Helsinki, May, 2012

Syed Ariful Alam

TABLE OF CONTENTS

ABSTRACT	2
PREFACE.....	3
1. INTRODUCTION	6
2. LITERATURE REVIEW	8
2.1. Oats and its components	8
2.1.1. Oat starch.....	11
2.1.2. Oat protein.....	12
2.1.3. Oat fibre and β -glucan.....	13
2.1.4. Oat lipids and their removal	15
2.2. Oat products	17
2.2.1. Oat flakes.....	18
2.2.2. Oat flour	19
2.2.3. Oat bran	19
2.2.4. Oat bran concentrates	19
2.2.5. Oat β -glucan concentrates	20
2.3. Oat in extrusion.....	22
2.3.1. Principles in the manufacture of snack foods by extrusion.....	23
2.3.2. Extrusion conditions.....	24
2.3.3. Physical properties of the extrudates.....	27
2.4. Conclusion of literature review.....	30
3. EXPERIMENTAL RESEARCH.....	32
3.1. Aim	32
3.2. Overview of the study	32
3.3. Material and methods.....	33
3.3.1. Extrusion materials.....	33
3.3.2. Extrusion design.....	35
3.3.3. Analyses	37

3.4. Results.....	42
3.4.1. Torque	42
3.4.2. Pressure at the die.....	43
3.4.3. Water content of the extrudates.....	45
3.4.4. Expansion of the extrudates	46
3.4.5. Hardness of the extrudates	47
<i>Texture of the extrudates</i>	50
3.4.6. Visual analyses of the extrudates	50
3.4.7. β -glucan analysis	53
3.4.8. Correlations	54
3.5. Discussion.....	55
3.5.1. Effect of raw material on the physical properties of extrudates.....	55
3.5.2. Effect of process variables on the physical properties of extrudates	60
3.5.3. Correlations	62
4. CONCLUSIONS	63
REFERENCES	64
APPENDICES	74
Appendix 1.....	74
Appendix 2.....	75
Appendix 3.....	75
Appendix 4.....	76

1. INTRODUCTION

Oats are the sixth largest cereal crop in the world but only small extent of the total oat production is used in human food formulations (Liu *et al.*, 2000). Oat products are consumed as ingredients in baked foods or in porridge for many years due to their high percentage of nutritious protein (Rzedzicki, 1999). Oats are the source of low cost protein with a protein content of 15–20% (dry matter basis) in dehulled oat grain. Moreover, people who suffer from coeliac disease can tolerate oat protein due to the absence of gluten (Thompson, 2003; Ahokas *et al.*, 2005). Although there is more nutritious protein present in oats than in wheat and corn, the use of oats in food products is still limited. High amount of lipid and fibre restrict the utilization of oats.

Nowadays the interest of using oats in designing food products is increasing due to the high amounts of soluble fibre, *i.e.*, β -glucan (Mohamed *et al.*, 2009). Oat β -glucans are able to influence lipid mechanism in human organisms and lower the total level of cholesterol in blood. Oat β -glucans not only decrease the total blood cholesterol, but also decrease the low-density and very-low-density lipoprotein (LDL and VLDL) cholesterol and increase high-density lipoprotein (HDL) cholesterol. LDL and VLDL are often termed as bad cholesterol, while HDL is regarded as good cholesterol. Moreover, oat β -glucans can stabilize blood glucose level (Rzedzicki, 1999; Rzedzicki *et al.*, 2000). Due to such health promoting properties, oat products have gained popularity to become as a part of human diet either as whole or as a fractionated form mostly as ready-to-eat (RTE) breakfast cereals, snack foods or bread (Mirmoghataie *et al.*, 2009). Snack foods have become a part of the lifestyle especially in the Western countries and cereal grains are generally used as their raw materials. However, snack products are often termed as junk food as they tend to be low in dietary fibres and proteins with essential amino acids. Several studies have showed that food products containing oat β -glucan can have a cholesterol-lowering effect (Wood *et al.*, 2007). In addition, the European Union has approved a health claim related to the blood cholesterol lowering effect of β -glucan (EU, 2011). Therefore, snack food products could be produced by incorporation of oat ingredients to improve their nutritional value (Prinyawiwatkul *et al.*, 1996; Thakur *et al.*, 2000).

Oats are more challenging in extrusion compared to other cereals such as corn and wheat. Due to the high content of lipids and dietary fibres (Fornal *et al.*, 1995), and relatively low content of starch, oats usually give poorly expanded and less crispy extrudates (Zarzycki

et al., 2010, Gordon *et al.*, 1986). The average percentage of lipids in oat grains is between 3 and 11% (Chang *et al.*, 1985; Vicidi *et al.*, 2004), and the total dietary fibre content typically between 6 and 9% (Liu *et al.*, 2000). Rzedzicki (1999) has even stated that it is not possible to obtain good quality extrudates by using only oat fractions. Cereal fractions rich in dietary fibre have poor gas-holding capacity during extrusion cooking, which makes it difficult to manufacture expanded products. In addition, high-fibre cereals often give hard texture to the final product thus fail to be accepted by the consumer. Therefore, processing of oat products by extrusion is difficult as oats contain high amounts of fibre, which caused poor formation of air bubbles in the extruded mass (Yao *et al.*, 2006). Less expanded, hard and dense extrudates containing oat β -glucan are reported in many studies (Liu *et al.*, 2000; Yao *et al.*, 2006). Oat ingredients could be blended with other cereal flours and starch to obtain puffed snacks with desired morphological, structural and sensorial properties (Liu *et al.*, 2000).

Wicklund (1995a) reported that extrudates made from whole grain oat flour were hard, dense and less expanded. Many researchers reported that increasing oat flour content in the extruded mass decreased the expansion of the extrudates, while addition of corn flour increased expansion (Liu *et al.*, 2000; Holguin-Acuna *et al.*, 2008). Addition of oat bran (10–50%) to the mass has shown to increase the hardness and decrease the expansion of the extrudates (Lobato *et al.*, 2010, Wicklund 1995a). However, addition of oat bran up to 20% has given expanded, porous and low density extrudates, but more than 30% addition caused non-expanded extrudates (Rzedzicki 1999, Rzedzicki *et al.*, 2000).

This study aimed to understand how different oat fraction affects the physical properties of extrudates. In many studies it has been observed that use of fat-containing oat fractions resulted low-quality extrudates. Therefore, defatted oat fractions were used in this study to observe how defatting of oat fractions enabled the production of expanded extrudates. One of the main objectives of this study was to determine the effects of extrusion process variables on the physical properties of oat-containing extrudates.

2. LITERATURE REVIEW

2.1. Oats and its components

Oats are a common northern cereal and belong to the *Poacea* family (Butt *et al.*, 2008). Oats have been used in the Nordic diet for almost two thousand years. However, they have been replaced more and more by other cereals since the beginning of the 19th century. Nowadays oats have regained a new interest due to its health-promoting effects (Duss *et al.*, 2004). Oats are a difficult raw material for bread making due to the absence of gluten compared for example to wheat. Therefore, oats are often used in porridge, breakfast cereals or in baking blended with wheat flour (Butt *et al.*, 2008). The major components of an oat grain are starch, protein, lipids and dietary fibres along with other minor components. The protein content of oats is relatively high (Table 1) and the amino acids are nutritionally balanced compared to other cereal grains. Although oats contain almost the same amount of protein compared to other cereal grains, such as wheat, rye and barley, oats have a lower amount of prolamin. The amount of prolamin in oats is 10–15%, while wheat, rye and barley have 30–50% prolamin (Thompson, 2003). Oats are the only cereal grain which have the globulin as a major source of protein. The globulin belongs to the group of avenalin and accounts for 70–80% of the total protein (Lasztity, 1998).

Dietary fibres of oats such as cellulose, lignin and non-starch polysaccharides (*i.e.*, β -glucan and arabinoxylan) have showed to prevent colon cancer. The soluble fibre of oats, commonly named as β -glucan, is known to reduce cholesterol and the risk of coronary heart disease. Oats may exert beneficial effect on controlling diabetes by reducing plasma glucose and insulin. Furthermore, oats may provide some health benefits through its minor components, such as tocopherols, tocotrienols and phenolic compounds (avenanthramides), based on their antioxidant activity (Peterson *et al.*, 2004). Anti-cancer effects may also be provided by lignans and phytosterols of oats (Peterson *et al.*, 2004).

Whole oat kernel contains significant amount of β -glucan, which is distributed through the endosperm, but concentrated mainly in the aleuronic and especially in the subaleuronic layers. The level of β -glucan in oat grains varies between 3–8% depending on the variety and the growing environment *e.g.*, climate and weather conditions (Butt *et al.*, 2008). Hull is the outermost part of oat grain, which encloses the oat grain and comprised about 25% of the total grain weight. Dehulled oat grain is composed of three fractions: bran, starchy endosperm and germ.

Table 1. Average proximate composition of the major cereal grains

Cereal grain	Average composition without dehulling (% by weight of wet basis) ¹					
	Carbohydrate	Protein (Lysine)	Fiber	Fat	Water	Ash
Barley	67.1	10.5 (0.40)	5.6	1.8	12.4	2.6
Corn	70.8	9.6 (0.23)	2.0	3.9	12.2	1.5
Oat	58.4	10.4 (0.39)	11.5	4.8	11.5	3.4
Rice	65.1	8.3 (0.27)	9.4	1.6	11.2	4.4
Rye	70.3	11.2 (0.39)	2.3	1.5	13.0	1.7
Sorghum	71.4	10.6 (0.23)	1.9	3.0	11.2	1.9
Wheat	70.0	12.0 (0.35)	2.5	1.7	12.1	1.7

¹FAO, 1987. The data presented here represents the mean value of 14 various sources

Bran consists of outermost pericarp, testa, nucellus, aleurone layer and subaleurone layer (Figure 1). The aleurone layer surrounding starchy endosperm contains large amount of protein and phenolic compound such as ferulic acid (Skoglund, 2008). Like barley, the main cell wall cementing material in oats is β -glucan (70–85%) that holds the cells together (Delcour *et al.*, 2010). The second most abundant cell wall material in oats is arabinoxylan. The ferulic acid-arabinoxylan complexes are concentrated in the aleuron layer (Autio, 2006). The total amount of arabinoxylan in oat grain is lower than in other cereal grains with a value that varies between 2 and 3% (Izydorczyk *et al.*, 2007).

Bran contains approximately 50% of the total grain proteins. In addition, the minor components such as vitamins and minerals are mainly present in the bran fraction and to a lesser extent in the starchy endosperm and germ. Starchy endosperm constitutes of about 55–70% of the total weight of the grain depending on variety. The great proportion of the lipids is mainly found in the endosperm (86–90%), followed by the bran and the germ of about 13% and 2.4% respectively (Skoglund, 2008).

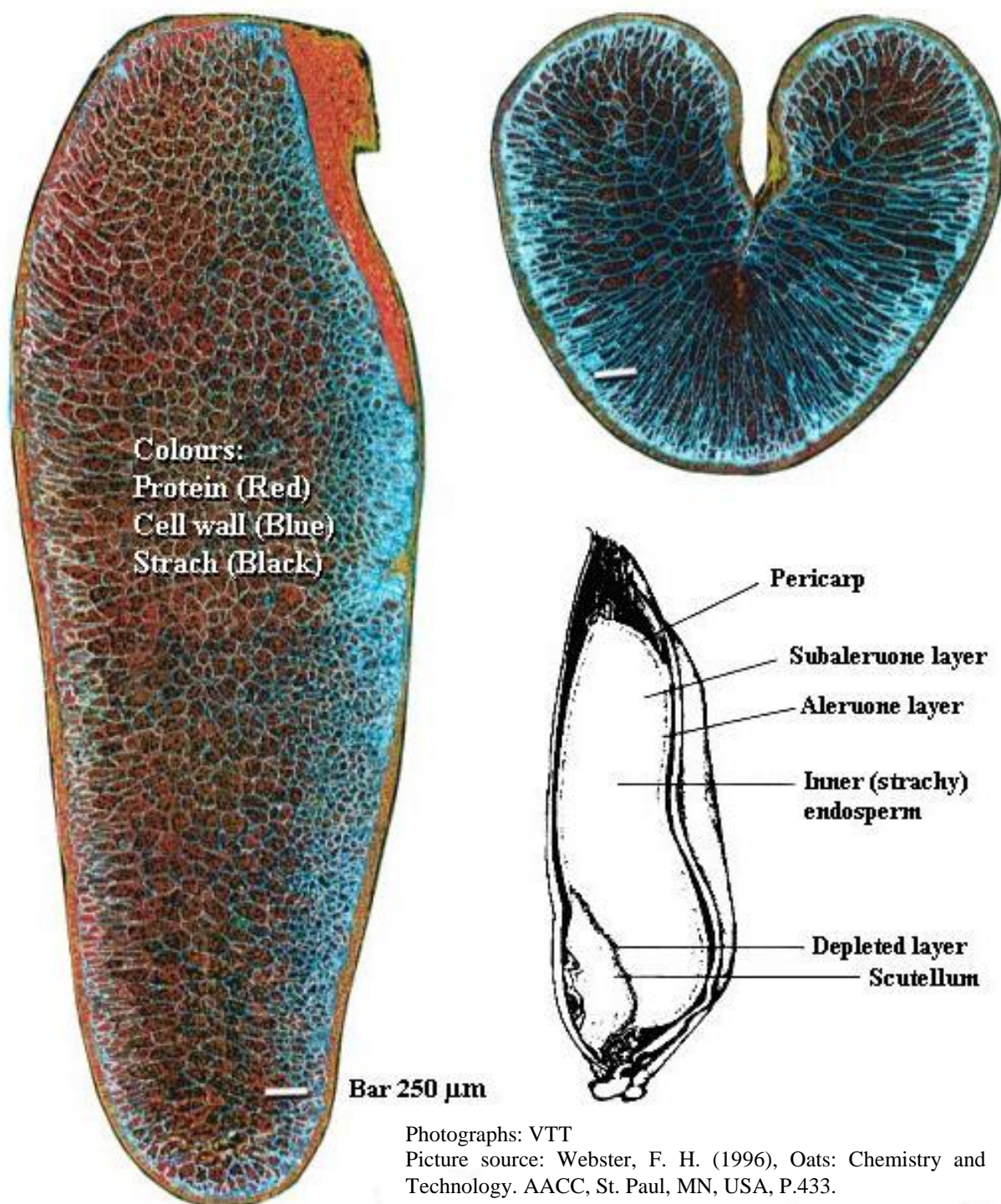

Figure 1. The cross-section of an oat grain showing the major components: [adapted from www.oatsandhealth.org, by courtesy of VTT Technical Research Centre of Finland]

2.1.1. Oat starch

Starch is the most abundant component of cereal grains and mainly found in the endosperm. Starch granules are not attached firmly in the surrounding continuous protein matrix, as the protein is localized in discontinuous structures. The main difference of oat starch compared to other cereal starches is that it cannot be separated easily from other components of the grain due to the strong bonding between starch and protein and because of the presence of β -glucan (Autio *et al.*, 2009). Therefore, starch industry does not use oats as the same extent as other grains such as maize and wheat. However, to achieve maximal usage of oats, an understanding of the morphology and functionality of oat starch is essential (Zhou *et al.*, 1998).

Starch is the most important ingredients in extruded products as it helps to increase expansion (Peterson, 2004). For a better expansion of the extruded product, starch content of the raw material should be 60–70% but in oat flour the percentage of starch is 44–61% (Fahrenholz, 1998). There are two types of starch molecules, one is linear amylose and other one is branched amylopectin (Regina *et al.*, 2010). The amylose versus amylopectin ratio influences the physical properties of starch. During gelatinization, amylopectin tends to absorb more water and swell, while amylose restrains swelling (Regina *et al.*, 2010). Waxy starches are rich in amylopectin and therefore absorb water at a greater extent than amylose (Fredriksson *et al.*, 1997). Amylose molecules line up themselves more readily and form extensive hydrogen bonding because of their linearity. Therefore, more energy is required to break these bonds and gelatinize the starch. The high amount of amylose increases the hardness of the extrudates and reduced the expansion. On the other hand, amylopectin rich starches provide crispy and more highly expanded products (Sullivan *et al.* 2010). The amylose content of oat starch is about 25–30% (Peterson, 2004).

Oat starch has different gelatinization characteristics; it has high shear susceptibility and thus behaves like waxy starch. After cooling, an unusually high viscosity is developed. Cooled oat starches are more elastic and adhesive, less firm and less susceptible to retrogradation compared to other cereal starches. Oat starch is usually a co-product of oat fractionation process and could be a good alternative in various applications, where other starches are typically used. For example, oat starch could be used in infant foods or in non-food applications, such as in paper industry or in pharmaceuticals (Wang and White, 1994)

The gelatinization of starch is an important phenomenon for starch-based food products. Gelatinization occurs when the starch granules are heated in a presence of water. During gelatinization of starch, the granules first swell by absorbing water and then the amylose starts to leach out of the granules. This increases the viscosity of the solution (Koester, 2008). In most cereal starches, for example wheat or barley, amylose is reported to be leached and solubilized prior to amylopectin during the heating. In oat starch, amylose and amylopectin are reported to co-leach from the granules (Shamekh, 2002). Oat starch has lower solubility and a little bit higher limiting viscosity compared to the wheat and corn starches. Only 17–26% of oat starch is reported to be solubilized when heated to 95 °C. Defatting of oat starch can increase the solubility of starch granule at lower temperatures (75–90 °C) but only a slight increase in the solubility was observed at 95 °C (Shamekh *et al.*, 1994). However, during the gelatinization of oat starch, less amylose was solubilized compared to wheat and corn starch. The higher solubility of oat amylopectin was due to the different molecular weight distribution compared to the other cereal starches (Shamekh *et al.*, 1994). The amylopectin weight average molecular weight (M_w , g/mol) of barley, corn and wheat were 1.3×10^8 , 4.9×10^8 and 3.1×10^8 , respectively, which were significantly lower than in oat starch: 8.4×10^8 (Jane, 2003; Stevenson *et al.*, 2007).

The gelatinization enthalpy of oat starch is reported to be lower compared to other cereal starches. For example, the gelatinization enthalpies of wheat, rice and barley starch are 11–12, 10–14 and 10.2–10.5 J/g, respectively, whereas 9.0–9.5 J/g for oat starch (Shamekh *et al.*, 1994). Moreover, the pasting behaviour of oat starch also differs from other cereal starches such as wheat, barley and corn: during the cooling of a gel, oat starch can form paste at a higher temperature (80 °C).

Starches containing high amylopectin require less severe extrusion cooking to become fully gelatinized compared to starches with high amylose content. During extrusion, the extent of gelatinization is dependent on the water content of the mass, extrusion temperature, torque and screw speed of the extruder (Koester, 2008).

2.1.2. Oat protein

The average percentage of protein in dehulled oat grain is about 12%, which is lower than in other cereal grains such as wheat, rye and barley. The percentage of protein in wheat, rye and barley dehulled grain is about 14, 13.5 and 13%, respectively, but the quantity may differ according to the growing region (Riahi *et al.*, 2003). For example, North American

oats contain approximately 15–20% protein (Peterson, 2004). The primary storage protein in oats is globulin, while in the case of other grains the major storage protein is prolamin. The denaturation temperature of oat globulin is 110 °C (Ma *et al.*, 2000) and occurrence of partial denaturation has been reported when the temperature reach 100 °C (Ma *et al.*, 2006).

Oat globulin is rich in lysine; while other grains (e.g., corn, rice and wheat) contain low content of lysine. Therefore, in oat proteins amino acids are nutritionally more balanced compared to other cereal grains. In corn, sorghum and barley the occurrence of ‘high-lysine’ mutants is common due to the reduction in the prolamin fraction. This is unlikely to occur in oat proteins as the prolamin content is already low. Oat protein concentrate can be made both by wet and dry extraction processes (Peterson, 2004). High purity oat protein concentrates can be manufactured by wet extraction method, but it is not suitable for food industry due to the high processing costs. When using defatted oats in a dry fractionation process, an oat protein content up to 73% has been obtained. Oat proteins could be a good source of plant based protein (Sibakov, 2011) and could be used for example in non-dairy yoghurt type products (Kaukovirta-Norja *et al.*, 2008; Sibakov, 2011).

2.1.3. Oat fibre and β -glucan

Dietary fibre is the edible part of the plants, which is resistant to human digestive system (Butt *et al.*, 2008). According to AACCI international, “dietary fibre is the remnants of the edible part of plants and analogous carbohydrate that are resistant to digestion and absorption in the human small intestine with complete or partial fermentation in the human large intestine. It includes polysaccharides, oligosaccharides, lignin and associated plant substances. Dietary fibres exhibit one or more of either laxation (fecal bulking and softening; increased frequency; and/or regularity), blood cholesterol attenuation, and/or blood glucose attenuation”. Depending on the solubility in water, dietary fibre can be classified into two categories: soluble and insoluble fibre. Soluble fibre such as gums, mucilages, pectin and hemicelluloses dissolve in the water. While insoluble fibre such as cellulose, lignin and remaining hemicelluloses does not dissolve in the water. Oats contain about 4.1 to 4.9% water soluble fibre (Tapola *et al.*, 2009), which is mainly non-starch polysaccharide called β -glucan. β -glucan forms viscous solutions and thus increases the viscosity in small intestine. Therefore, intestinal transit delays and extends the digestion periods. Moreover, it has capability to delay gastric emptying process and to slow the sterol and glucose absorption in the intestine. Oat β -glucans (Figure 2) help maintaining

normal blood sugar levels and can be useful in decreasing blood cholesterol levels. On the other hand, oats contain 6–7% insoluble fibres (Tapola *et al.*, 2009) and they are capable to absorb bile acids and due to a high water-holding capacity contributes to increased fecal bulk (Butt *et al.*, 2008). Although having such positive physiological benefits, the daily intake of soluble dietary fibres, especially β -glucan, is below the recommended level (5–10 g/day for adult) in most developed countries (Keenan *et al.*, 2007; Drzikova *et al.*, 2004). However, as much as 10–30 g/day for adults can provide additional LDL-lowering effects for some individuals (Keenan *et al.*, 2007, Santillan-Moreno *et al.*, 2009).

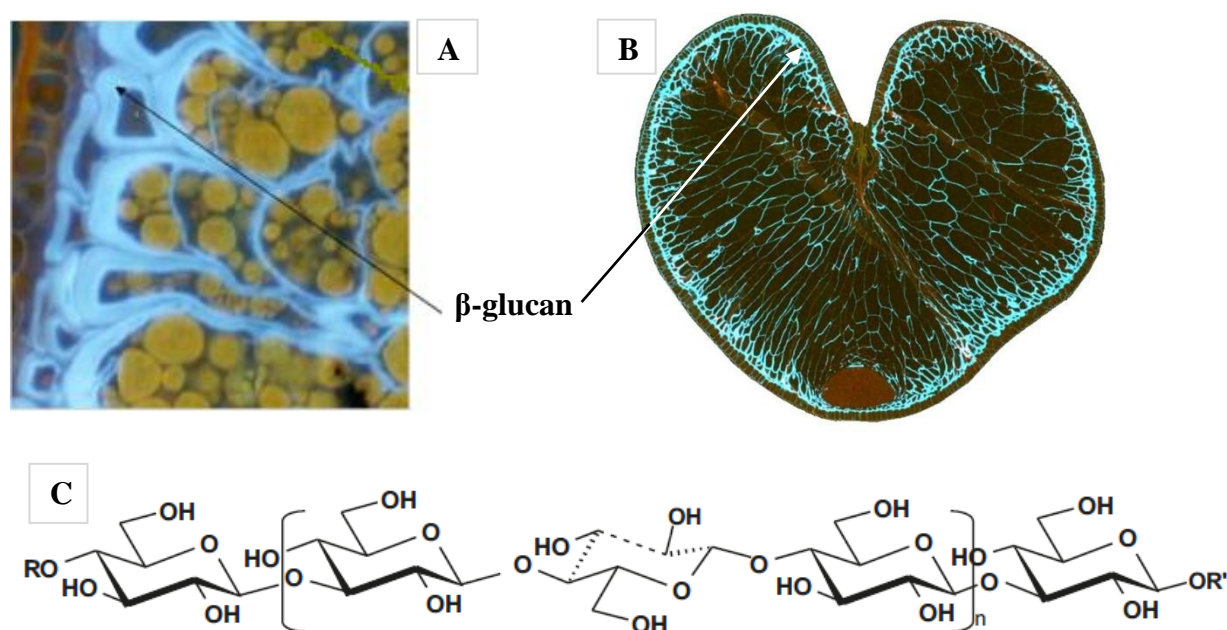

Figure 2. [A] Distribution of β -glucan in the cell walls of oat grain (adapted from Lehtinen, 2009). [B] Microscopic picture of the cross section of oat grain showing the distribution of β -glucan in the cell walls of aleurone and sub-aleurone layer and is visualized as Calcofluor blue (by courtesy of VTT Technical Research Centre of Finland). [C] Chemical structure of oat (1 \rightarrow 3), (1 \rightarrow 4)- β -D-glucan and the building block cellotriose (Kivelä, 2011).

Oat β -glucans are non-starch, linear and unbranched polysaccharides (Figure 2, C). The chemical structure of oat β -glucans are composed of β -D-glucopyranosyl units linked by β -(1 \rightarrow 4) and β -(1 \rightarrow 3) links. About 70% of the linkages are β -(1 \rightarrow 4) and the remaining 30% are β -(1 \rightarrow 3) linkages (Duss *et al.*, 2004). Oat β -glucan has been approved for a health claim in the USA under FDA (Food and Drug administration of USA) regulations since 1997 due to its ability to lower blood cholesterol (FDA, 1997). Health claim related to blood cholesterol lowering effect of oat β -glucan also has been approved by European Food Safety Authority (EFSA, 2010). Both FDA and EFSA health claims are based on a daily intake of 3g oat β -glucan. However, the current average intake of β -glucan in the

USA is well below that is about 3–4 g/day for adult (Keenan *et al.*, 2007; Reyna-Villasmil *et al.*, 2007).

2.1.4. Oat lipids and their removal

Oat lipids are mostly present in the starchy endosperm and in the bran. Oats have significantly higher lipid content compared to other cereal grains. Depending on the variety of oats, lipid content of oat grains varies within a range of 3 to 12% (Wicklund *et al.*, 1997). About 80% of the total lipids remain in the endosperm, while endosperm of other grains usually contains about 50% of lipids. The aleuronic layers, which are concentrated into the bran, contain high amount of lipids. Like other cereal grains, the majority of oat lipids are composed of long chain fatty acids, such as triacylglycerols and other acyl lipids. The most of the studies have reported that the following fatty acids are the most common in different oat cultivars: palmitic acid (13–26%), stearic acid (1–3%), oleic acid (22–47%), linoleic acid (25–52%) and linolenic acid (1–3%). About 95% of the total fatty acids are composed of these five fatty acids. Some studies have reported that oat cultivars contain also lauric, palmitoleic, arachidic acids (less than 0.1%), and unsaturated C₂₀ acids (0.5–3.0%). Those studies have also reported that trace amounts of lignoseric and nervonic acids were present in some oat cultivars (Zhou *et al.*, 1999).

Oat lipid fractions can be classified as nonpolar (free or neutral) lipids and polar (bound) lipids. Polar lipids are typically used as emulsifiers while non-polar lipids can be used as vegetable oil. Among the nonpolar lipids, most abundant class is the triacylglycerols (33–79%) in various cultivars of oats in Canada, Finland and USA (Zhou *et al.*, 1999). Oat kernels may contain 0.8–2.8% polar lipids on a dry weight basis, which is a mixture of phospholipids and glycolipids (Doehlert *et al.*, 2010). The fatty acid composition is important from both nutritional and technological point of view. For example, linoleic and linolenic acids are termed as essential fatty acids in mammalian nutrition. On the other hand, palmitic acid increases oil stability by preventing peroxidation and linolenic acid causes oil instability (Zhou *et al.*, 1999). Oat oil is favorable to use in foods as it contains high amount of monounsaturated oleic acid. It has higher extent of oleic acid compared to various healthy vegetable oil such as soybean and sunflower oil (Peterson, 2004). Although having some health benefits, oat lipids have showed to have excessive amounts of free fatty acids, which have adverse effects on the flavor and storage quality of oat containing products (Zhou *et al.*, 1999).

Polar lipids can be extracted by polar solvents (Figure 3) such as methanol, ethanol, butanol or by chloroform, while nonpolar lipids can be extracted by non-polar solvents such diethyl ether, petroleum ether or hexane (Zhou *et al.*, 1999). Although nonpolar solvents are very effective in removing nonpolar lipids, they are poor solvents for polar lipids particularly phospholipids. By using nonpolar solvents, 80–90% of the oat lipids can be extracted (Wicklund, 1997). There is an alternative lipid extraction and fraction process also available, which utilize super critical fluid particularly super critical carbon dioxide. Lipid extraction by using super critical carbon dioxide gives more homogenous nonpolar lipids compared to the extraction with traditional (e.g., hexane) non-polar solvents (Zhou *et al.*, 1999).

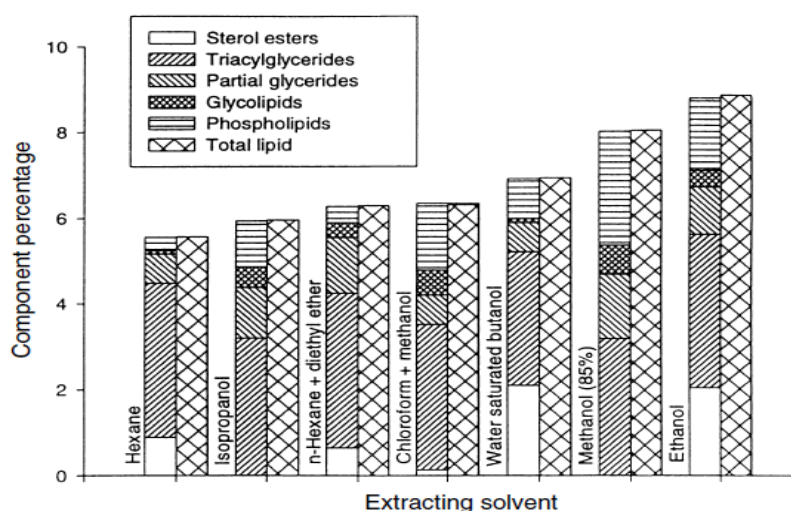

Figure 3. Composition of oat lipids (%) extracted from oats by using different solvent [Adapted from Zhou *et al.*, 1999]

The internal lipids located inside the starch granule is termed as starch lipids. By using polar solvent, extraction of starch lipids takes long time at ambient temperature. On the other hand, nonstarch lipids can be extracted within 10 minutes by using multiphase polar solvents such as EEW (ethanol-ether-water), WSB (water-saturated n-butanol) or BEW (benzene-ethanol-water). After removing nonstarch lipid, starch lipids can be extracted within 3 hours by using WSB system at 100 °C (Wicklund, 1997, Zhou *et al.*, 1999).

2.2. Oat products

In order to produce oat-containing food products, which are in line with the demand of the consumer, oats are usually cleaned, tempered, dehulled, cutted and milled. The cleaning of oats is carried out to remove dust, which usually disturbs further processing. Oats contain high levels of lipids. The lipase enzymes found in oats may catalyze hydrolytic reactions of lipids into fatty acids and further, when oxidized by lipoxygenase enzymes, give free fatty acids, which can cause rancidity of the final oat product (Skoglund, 2008). Therefore in food production, oats are heat treated in order to inactivate enzymes, which are responsible for the changes in lipids. Moreover, heat treatment also improves the flavour and inactivates microbial contaminants. After heat treatment the following step is dehulling. In dehulling, the grains are forced centrifugally against an impact ring, which removes the hulls from the grain. Subsequently, air classification separates the hulls from the dehulled grains (Skoglund, 2008).

During milling of oat grains, steam is added to soften the grains so that they form flakes with a minimal breaking. The steaming process also helps to inactivate undesired enzymes and contributes to the formation of the flavour. Flaking of intact oat grains produces rolled oats of about 0.5–0.8 mm thickness. Thinner flakes could be produced by cutting the grains into pieces of about 0.25–0.40 mm thickness, which are often used for the production of instant cooking oat flour. After flaking, rolled oats are cooled down with air at 45 °C and the moisture content is kept approximately at 9–11.5% (Skoglund, 2008). By further milling of oat flakes, oat flour can be produced with the use of an impact-type mill. In the mill exhaust air is passing through the system to prevent relatively high fat oat flour to stick into the chamber of the mill. To make instant baby foods, drum drying process is commonly used, where rolled oats are milled and mixed with water. The oat slurry is then applied to steam-heated rotating rollers and produced thin film is further milled to obtain final product. However, defatting of oats may also be necessary to avoid the undesired blocking of the material flow. To remove lipids, several techniques can be applied, for example organic solvent (ethanol or n-hexane) or supercritical CO₂-extraction (Mälkki, 2001).

Among different oat fractions (Table 2), the β -glucan enriched oat bran has attracted the most attention to be used in functional food formulations. Oat lipids, especially polar fractions, are also potentially valuable. Other fractions like starch and protein have received significantly smaller attention. Some of the minor components of oats, such as

polyphenolic avenathramides, can be used due to their anti-oxidative activity and health-promoting properties (Peterson, 2007). However, these components are so small in quantity that they are less relevant for food applications.

Table 2. Composition of different oat fractions

Oat fraction	Processing	Starch content (%)	Protein content (%)	Total dietary fibre content (%)	β -glucan content (%)	Fat content (%)	Ash content (%)
Grains	Dehulling grains	44–61	12–18	6–9	3–5	5–10	2–3
Bran	Dry milling	64–70	12–20	12–24	5–10	5–11	2–6
Bran concentrate	Solvent extraction and dry or wet milling	n.a.	17–24	32–45	16–25	3–5	4–7
Fine flour	Dry milling	58–64	11–12	5–10	1–3	3–4	0.5–1
Coarse flour	Dry milling	65–77	19–20	5–10	1–5	4–5	2–3
β -glucan concentrate	Extraction and solvent isolation	n.a.	7–22	n.a.	60–80	0.1–1	3–4

Butt *et al.*, 2008; Doehlert *et al.*, 1997, Fahrenholz, 1998; FAO, 1987; Mälkki *et al.*, 2001; and Sibakov *et al.*, 2011

n.a.= not available

2.2.1. Oat flakes

Commercially available oat fractions include rolled oats and oat flakes. Rolled oats are produced by flaking whole oat grains, which are the thicker than oat-flake products. The flake thickness of rolled oats varies from 0.5–0.9 mm depending on their use in the food product. The thick flakes need longer cooking times than the thinner flakes, but have the ability to maintain flake integrity for an extended period. The majority of oat-based food products consists of flakes that may need further processing before inclusion into the final food product. Oat flakes are marketed as two forms such as quick and instant oat flakes. Quick oat flakes are usually 0.4–0.6 mm thick and produced from oat grains by cutting them into 3–4 pieces before final steaming and milling process. Quick oat flakes require shorter cooking time than whole oat flakes. On the other hand, instant oat flakes are 0.3–0.5 mm thick and subjected to precooking, which results in rapid cooking (Oat ingredients, 2010).

2.2.2. Oat flour

Oat flour is finely ground material, which is obtained from clean dehulled oat kernels. By dry milling the oat grains, approximately 65% oat flour is obtained and about 35% remains as oat bran (Lim *et al.*, 1992). Oat flour has high lipid content, which makes the flour sticky and thus difficult to handle in food processes (Liu *et al.*, 2000). Oats have approximately 4.8–5.1% lipids of the whole grain and 6.4–7.2% lipids in dehulled grain (Fahrenholz, 1998; FAO, 1987). Therefore, oat flour is commonly blended with other cereal flours (20–50% of oats and 50–80% of other cereals) in food formulations (Cremer *et al.*, 2003). However, different fractions of oats can be used in the formulation of various types of food products (Liu *et al.*, 2000).

2.2.3. Oat bran

Oat bran is the fibre-rich outermost layer of oat kernel, prepared by milling clean oat grains and separated from flour by sieving (Gates *et al.*, 2005). According to AACC committee “Oat bran is the food which is produced by grinding clean oat grains or rolled oats and separating the resulting oat flour by sieving, bolting, and/or other suitable means into fractions such as the oat bran fraction is not more than 50% of the original starting material, and has a total β -glucan content of at least 5.5% (dry weight basis) and a total dietary fibre content of at least 16% (dry weight basis), and such as at least one-third of the total dietary fibre is soluble fibre” (AACC, 1989).

Oat bran contains approximately 6–16% dietary fibre of which almost one third is soluble fibre, such as β -glucan. Oat bran is used in various foods as it contains 17% protein, β -glucan at least 8–12% and 16% total dietary fibre (Åman *et al.*, 2004). Moreover, oat bran contains vitamins, minerals and approximately 8% fats (Butt *et al.*, 2008). Oat bran is mainly used in food products to enrich nutritional value as it has been proved to reduce blood pressure, the risk of diabetes and coronary heart disease, as well as it may be capable of preventing cancer (Brown *et al.*, 1999; Ripsin *et al.*, 1992, Stevenson *et al.*, 2008).

2.2.4. Oat bran concentrates

Oat bran concentrates are a coarse light brown fraction containing β -glucan up to 40% (Sibakov *et al.*, 2009). Oat bran concentrate can be produced by reducing the amount of non-fibre components (Mälkki *et al.*, 1993). To obtain oat bran concentrate, dehulled or naked oats are usually subjected to dry milling and classification to separate a coarse

fraction (containing cell wall material enriched in sub-aleurone layer) from the finer endosperm containing fraction. At the second stage, pre-enriched coarse fraction is subjected to dry milling and classification to separate the residual starch from the coarse material. Dry milling can be done by roller or impact mill, while dry classification is usually done by sieving or air classification. The prepared bran concentrate can be used in various food products, such as meat, ready-to-eat cereal bar, drinks and candies (Mälkki *et al.*, 2003).

2.2.5. Oat β -glucan concentrates

Wet extraction methods

Oat β -glucan concentrate can be prepared from the bran by extraction process using hot water or alkali followed by purifications and precipitation of the gum by alcohols or ammonium sulfate. The wet extraction of oat β -glucan fraction can be done by the following methods such as enzymatic hydrolysis of non- β -glucan components, acid, base or solvent precipitation and wet sieving of the water insoluble materials. By wet extraction method, up to 90% β -glucan content can be achieved in the extracted fraction. An example of enzymatic hydrolysis of non- β -glucan components is α -amylase induced hot water extraction method developed by United States Department of Agriculture (USDA): After the extraction process, solid particles containing β -glucan are separated out from the extracted fraction and dried (Inglett, 1989). To separate soluble fibre, further modification of the dried product is needed which is done by high-temperature mechanical shear. The obtained product gives the mixture β -glucan containing solids in water and non-soluble fibre. By filtration or centrifugation, non-soluble fibres can be removed and the liquid is dried to produce the soluble β -glucan concentrate (Inglett, 1995).

Another wet extraction of β -glucan have been developed by the researchers of University Alberta, which is aqueous ethanol aided extraction followed by enzymatic treatment. By this method, starch and protein is hydrolysed but β -glucan remains insoluble. The recovery of the β -glucan concentrate is done by screening or filtering of the slurry (Vasanthan and Temelli, 2002). Enrichment of β -glucan can also be done by the method based on enzymatic treatment aided wet milling, followed by a sequence of process such as centrifugation, ultra filtration, freezing and precipitation step (Kvist and Carlsson, 2001; Kvist and Lawther, 2004).

There is a method available for β -glucan enrichment, which is an entirely aqueous method. In this method, starch is removed first by screening of the slurry of milled oat bran and cold water. To solubilize β -glucan, the material which does not go through the screen is extracted with alkaline solution. Further acidification can help to precipitate the protein. To collect β -glucan concentrate, remaining solution can be removed by evaporation or even micro-filtration (Potter and Fisher, 1999)

Wet extraction method can separate the oat components into soluble and insoluble part with high purity in compared to dry extraction method. Sibakov *et al.* (2012) reviewed that “Wet processes are typically limited by high viscosity of the aqueous extracts even at low β -glucan concentrations, which leads to large liquid volumes and high costs related to drying and solvent recovery steps”. Therefore, dry fractionation method would be more economical to develop food ingredient which needs less intensive drying with higher mass yield compared to the wet extracted highly purified β -glucan concentrate.

Dry extraction methods

The oat bran can be enriched in terms of β -glucan using dry fractionation processes of oat flour. Higher percentage of β -glucan can be achieved by dry fractionation processes compared to the traditional fractionation process. One of the most efficient dry fractionation processes (Figure 4) has been described by Sibakov *et al.* (2011). Firstly, oat flour is defatted by supercritical CO₂ to remove lipids followed by milling and air classification so that the amount of β -glucan in the bran fraction increases. Removal of lipids before milling is important to guarantee that the different grain constituents (e.g., aleuronic cells walls, starch and proteins bodies) are more easily dissociated from each other (Heneen *et al.*, 2009). Furthermore, lipid removal ensures more effective separation of protein, starch and bran. By this way, β -glucan content of the bran fraction can be increased up to 35% with a yield of 8–9%. The other fractions obtained by this process are: starch (ca. 75–80% yield, 70–80% starch concentration) and protein (ca. 5–10% yield, up to 70% protein concentration). This fractionation process is very promising as it can give fraction with 40% of β -glucan. The benefit of the process is that it obviates the need of expensive and energy-consuming drying processes (Sibakov *et al.*, 2011). In previous studies β -glucan concentrations have been 18–25% when using non-defatted oats as raw material. Defatting with organic solvents has given a bit higher percentage (up to 27%) of β -glucan after using dry fraction methods (Mälkki, 2001).

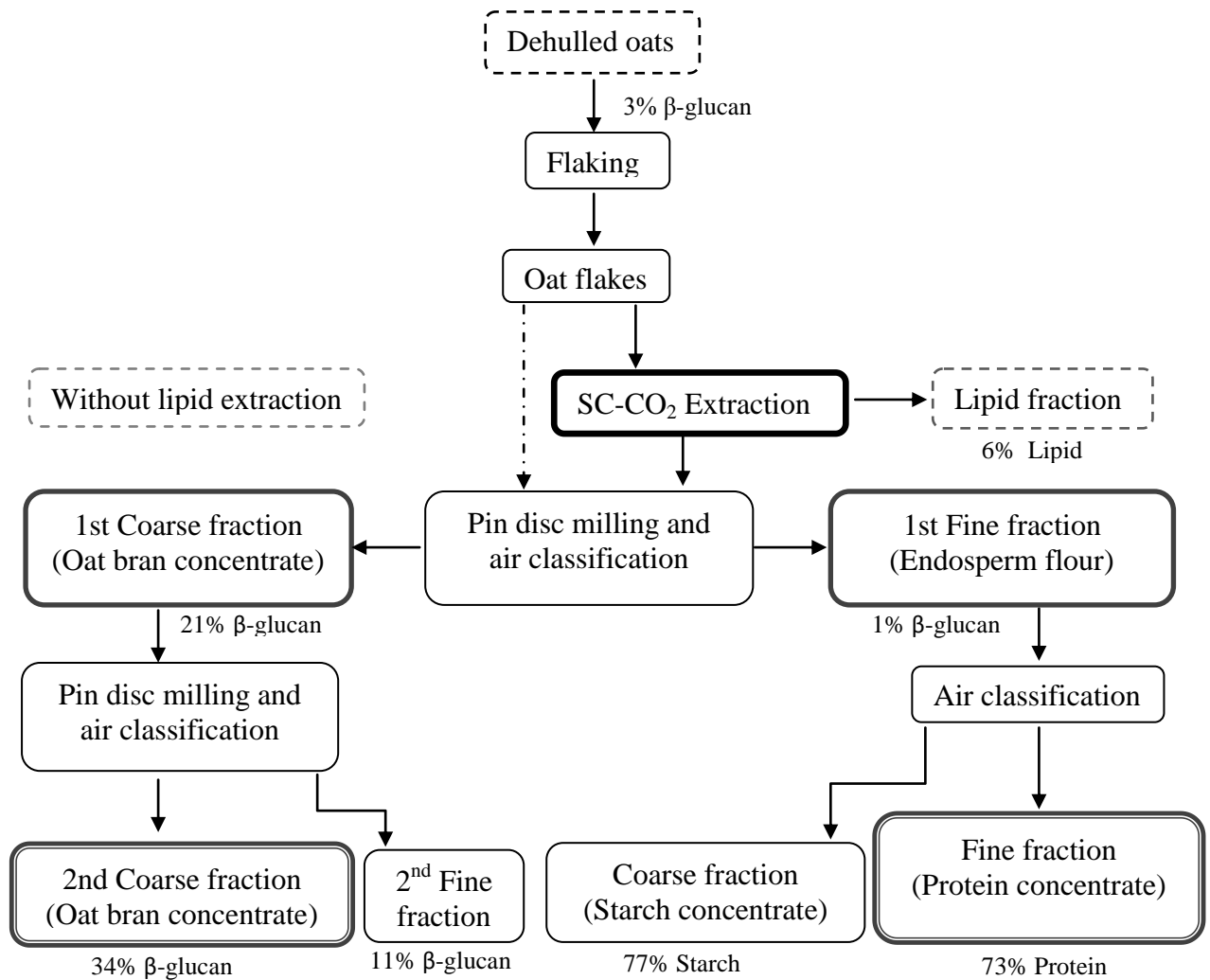

Figure 4. Flow diagram of oat fractionation process by using supercritical carbon dioxide (SC-CO₂) [Adapted from Sibakov *et al.*, 2011]

2.3. Oat in extrusion

Oats encounter notable difficulties during extrusion (Fornal *et al.*, 1995). The high content of lipids, low contents of starch and high fibre content make the selection of process difficult (Gordon *et al.*, 1986; Zarzycki *et al.*, 2010). Among the oat fractions, oat flour and oat bran can be used in extruded products. The major problem to use oats in extruded snacks is high lipid content (7–9%). For this reason, oats need higher amounts of energy input for cooking at low gelatinization temperature (Riaz, 2006). The high lipid content may decrease the conversion of starch through the lubrication effect of the starch melt. This lubricating effect may reduce the degree of gelatinization or prevent the starch from mechanical breakdown, thus reducing the expansion. Faubion and Hosney (1982) studied that expansion of wheat starch extrudates was reduced when 1% lipids were added to the extrusion. Moreover, high lipid content may also reduce the friction between the dough and screw (Lin *et al.*, 1997). Oats have high levels of dietary fibre, which also lead to poor

expansion of the extrudates. Therefore, oats are used in snack product usually at very low extent. Several studies have showed that increased dietary fibre content increased the hardness of the extruded snacks and decreased the expansion rate by rupturing the cell walls before the expansion of gas bubbles (Lue *et al.*, 1991; Mendonca *et al.*, 2000; Yanniotis *et al.*, 2007). Dietary fibre particles usually decrease the expansion of extrudates. Therefore, extruded product with high fibre content is usually dense, hard and not crispy (Lue *et al.*, 1991; Jin *et al.*, 1994). Moreover, dietary fibre can also bind some water present in the matrix thus reducing its availability for expansion (Moraru and Kokini, 2003).

To get rid of the difficulties caused by oat lipids (for example unstable run of extruder and stack of oat fraction in the feeder), removal of oat lipids can be done before extrusion.

2.3.1. Principles in the manufacture of snack foods by extrusion

Breakfast cereals and expanded snack foods are usually porous, brittle and solid foams (Cremer *et al.*, 2003). Extrusion cooking is a high temperature short time process which can be used to produce puffed snack products (Lobato *et al.*, 2010). The extrusion process involves intense mixing of the raw material to obtain properly dispersed and homogenized dough (Yağcı *et al.*, 2012). Raw materials are fed into the barrel of extruder continuously. The obtained products are called extrudates.

A twin-screw extruder consists of two horizontal intermeshed screws inside a barrel. The screws are fitted so that they can rotate easily with each other and can simultaneously sweep the barrel's edge. Sweeping of the screws is an important property by which mass inside the barrel comes out from the extruder continuously, even in a case of materials with high viscosity. To monitor the extrusion process, different kinds of sensors, such as thermo-couples and pressure sensors, are connected to the barrel and die of the extruder. Different segments of the barrel have usually individual temperature control (Yağcı *et al.*, 2012).

The control of the extrusion process involves temperature profile within the extruder barrel, screw speed, feed rate and water content of the mass. These variables affect the physical properties of the extrudates (Rzedzicki *et al.*, 2000). Water content of the mass has a great influence on the quality of extrudates. Low water content of mass is preferred as the expansion of extrudates usually increases when decreasing the water content of the mass (Yağcı *et al.*, 2012). If the water content of the mass is too high, extrudates may

expand significantly but they collapse before cooling, causing hard and undesirable texture to the final product.

The chemical composition of the raw materials, such as the percentage of protein, starch and lipids also affect the physical properties of the extrudates (Battacharya *et al.*, 1994). Raw materials used in the extrusion process are conveyed through the barrel of the extruder and heated throughout the residence time. Inside the barrel, the mass temperature is above the normal boiling temperature of water, and the high pressure keeps water in liquid form. When the product comes out through the die, a sudden drop of the pressure to atmospheric pressure takes place. At the die exit the superheated water evaporates and causes expansion of the extrudates (Figure 5). As water comes out from the product in the form of steam, air is trapped in the empty places. Therefore, product stretches and gives expanded extrudates (Yağcı *et al.*, 2012).

Shear force is defined as a force, which is applied parallel or tangential to material, which is opposite to the normal force applied perpendicularly. High screw speed increases shear force and controls mass temperature, torque and pressure, which in turn has an influence on the degree of expansion (Sokhey *et al.*, 1994).

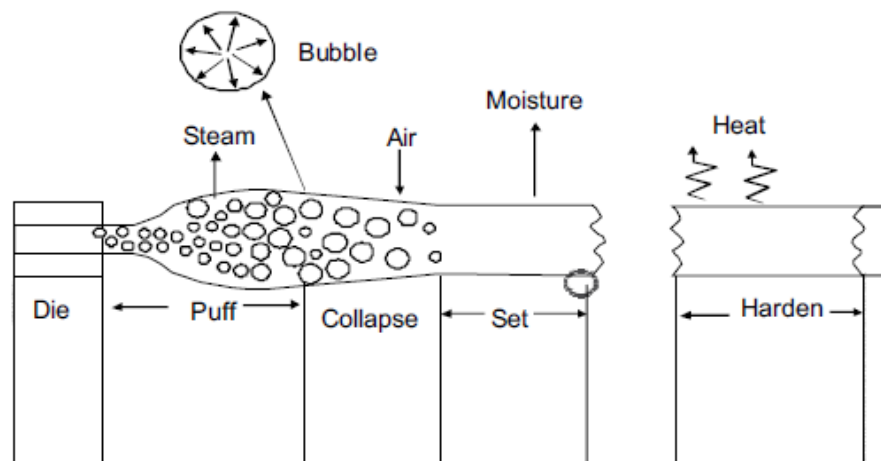

Figure 5. Schematic diagram of the mechanisms in expansion [Adapted from Pai *et al.*, 2009]

2.3.2. Extrusion conditions

The extrusion technology is a good way to incorporate dietary fibre fractions into the structure of the final product. Slight changes in process or in the composition of the raw materials, may result into remarkable changes in the quality of the extrudates. This can be observed especially in the case of the products containing increased amount of dietary fibre

(Desrumaux *et al.*, 1999). Addition of large amount of oat fraction decreased expansion and increased hardness (Rzedzicki *et al.*, 2000; Liu *et al.*, 2000). The combination of low screw speed and lower water content can efficiently improve the quality of extrudates when using raw materials with high fibre content (Ainsworth *et al.*, 2007; Stojceska *et al.*, 2008). Increasing the amount of starch content can also produce extrudates with increased expansion and reduced hardness (Stojceska *et al.*, 2008).

Although extrusion is a rather complex and difficult process, properly selected raw materials and processing conditions can provide extrudates with good physical properties (Zarzycki and Rzedzicki, 2009). The incorporation of dietary fibre components into extrusion process caused changes in the expansion, texture and density of the extrudates (Liu *et al.*, 2000). Rzedzicki *et al.* (2010) reported that the maximal amount of oat fractions such as flour and bran in the extruded blends may be approximately 18%. Higher levels of oat components caused raw material slippage inside the extruder. Several studies show that good quality extrudates with only oat components were not possible to be produced by single screw extruder due to the high lipid content (Rzedzicki *et al.*, 1999).

Singh *et al.* (2006) reported that extrusion condition has significant effect on the nutritional quality of the food products. The nutritional quality of the extrudates can be improved by using substantially low temperature and high moisture content. Elongated residence time and reduced sugar content of the mass may also cause destruction of nutritional value. Therefore, to obtain nutritionally balanced extruded products along with good physical attributes, it is necessary to carefully determine the optimal processing conditions. Moreover, the choice and proper formulation of the raw material is also needed. Several studies have been carried out with oat fractions (Table 3), to evaluate the effect of processing conditions on the physical properties of extrudates, such as expansion, hardness and porosity. In addition, other properties, such as water absorption and water hydration, have to be optimized to improve the overall quality of extrudates.

According to the literature, oat flour has been investigated more than oat bran in extrusion studies (Table 3). In most of these studies, oat fractions (flour and bran) are blended with corn flour or corn starch. Although 100% oat flour was used in some experiments, the percentage of oat fraction was below 40% in most of the experiments. Oat fractions can be used in extrusion only when blended with other cereal flour or starch. In the previous studies, it was not possible to use oat bran alone without blending it with other ingredients. The feed rate varied in different experiments according to the size of the extruder (mostly

22–45 kg/h). The screw speed also varied according to the equipment used: in single screw extruders, the screw speed was lower (70–140 rpm) than in the twin-screw extruders (200–400 rpm). The barrel temperatures ranged between 70–220 °C and water content of the mass 11–33%. When the percentage of oat flour was increased, more water was needed. On the other hand, oat bran needed less water, as the percentage of oat bran increased, lower water content gave better expansion.

Table 3. Recipe and processing condition used in several extrusion experiments

Recipe	Feed rate (kg/h)	Screw speed (rpm), equipment	Extrusion temperature (°C)	Water content of the feed (%)	Reference
Whole and sifted oat flour (100%)	22–34	300; twin-screw extruder	120–180 (barrel temperature)	25–30	Wicklund 1995a,b
Wheat flour, wheat starch and oat flour	40	300; twin-screw extruder	(30–90)/(60–90)/(90–120)/(100–150)/(125–175) (temperature profile)	22–28	Singh <i>et al.</i> , 1997
Oat flour (55–100%) and corn flour	45	200–400; twin-screw extruder	n.a.	18–21	Liu <i>et al.</i> , 2000
Corn semolina and oat bran (3–8%)	n.a.	100; single screw extruder	(125–160)/(145–180)/130 (temperature profile)	12–16	Rzedzicki <i>et al.</i> , 2000
Corn flour, corn starch, oat flour (20%) and raw chickpea flour	22–26	220–340; twin-screw extruder	110 (barrel temperature)	11–15	Ozer <i>et al.</i> , 2004
Oat bran (20–80%) and corn semolina	n.a.	72; single and twin-screw extruder	120–220 (barrel temperature)	15–3	Rzedzicki <i>et al.</i> , 2005
Oat flour (66%) , wheat starch, sugar, salt and sodium bicarbonate	2	230; twin-screw extruder	125–180 (barrel temperature)	16–30	Yao <i>et al.</i> , 2006
Corn bran and oat flour (50–100%)	n.a.	140; single screw extruder	70–100 (barrel temperature)	25	Holguin-acuna <i>et al.</i> , 2008
Oat bran (37.5%) , defatted soy flour, corn starch	n.a.	70; single screw extruder	80/100/110–130 (temperature profile)	n.a.	Lobato <i>et al.</i> , 2010
Oat flour, oat bran (5–15%) and corn flour	n.a.	110; single screw extruder	(125–160)/(145–180)/120 (temperature profile)	13–16	Zarzycki <i>et al.</i> , 2010

n.a.= not available

2.3.3. Physical properties of the extrudates

2.3.3.1. Effect of oat flour

Among all components of oat flour, lipids and fibres have found to have the biggest influence during the extrusion, because they cause low expanded extrudates without proper crispiness work. Higher than 5% lipid content did not give desired properties for the extrudates in previous studies (Wicklund, 1995a,b). Increased porosity and decreased density was found when oat flour was blended with corn flour (Liu *et al.*, 2000; Ozer *et al.*, 2004). Increasing the amount of oat flour content decreased the expansion and increased hardness of the extrudates, while addition of corn flour increased the expansion (Liu *et al.*, 2000; Holguin-Acuna *et al.*, 2008). The reason for low expansion is the low quality of starch in oats, which contains small amount of amylopectin. Low expansion and hard texture might also caused by the high fibre content of oat (Wicklund, 1995b). Wicklund (1995a) reported that extrudates made of whole oat flour had more bulk density than the extrudates made from sifted oat flour. The removal of lipid and excess amount of dietary fibre can give better expansion to the extrudates (Kumagai *et al.*, 1987; Wicklund, 1995a).

2.3.3.2. Effect of oat bran

Extrusion cooking of oat bran resulted in poor expansion as the bran particles tended to rupture the cell wall and make holes in the cells (Wicklund, 1995a). Water evaporates through these holes, which results dense and poorly expanded extrudates. Oat bran has been reported to reduce the expansion from 10–50%, depending on the processing condition and the composition of the raw materials (Wicklund, 1995a). Increased amounts of oat bran (e.g., 20–50% of solids) have showed to increase the hardness values (125–288 N) and decreased radial expansion ratio (1.07–1.24) of the extrudates (Lobato *et al.*, 2010). Another study showed that when the percentage of oat bran (9–18%) in the mixture was increased with temperature (140–180 °C), the radial expansion was found to decrease (Rzedzicki *et al.*, 2000). Leu *et al.* (2000) and Rzedzicki *et al.* (2000) showed that increasing oat bran content decreased the porosity and increased the density of the extrudates. Addition of high percentage of oat components disturbed the extrusion (material sliding and unstable run of the equipment) in single screw extruder, which decreased the efficiency of the extruder. The researchers also claimed that it was not possible to obtain high quality extrudates by using only oat component in twin-screw extruder even though the trials were less unstable compared to the single screw extrusion.

Addition of a small amount of milk protein (0.5–1%) could give a slightly better expansion (Rzedzicky, 1999; Rzedzicki *et al.*, 2000). Addition of whey protein concentrate (up to 10%) or whey protein isolate (up to 25%) was reported to increase expansion in several studies (Faubion and Hosenev, 1982, Onwulata *et al.*, 2001, Onwulata *et al.*, 2008, Santillan-Moreno *et al.*, 2009). Lobato *et al.* (2010) suggested that oat bran content of about 37% of solids could be blended with other ingredients to obtain good quality extrudates. They proposed that addition of inulin (a mixture of oligomers and polymers), 4.5% of solids, could give increased expansion and decreased hardness of the extrudates. Rzedzicki (1999) and Rzedzicki *et al.* (2000) reported that oat bran content up to 20% of solids can give highly expanded porous extrudates with low density, if the percentage of oat bran is more than 30% in the mixture. They recommended that 9–12% oat bran can be added to obtain expanded products. Higher percentage of oat bran addition probably increases the lipid and dietary fibre content of the mass, which might lead to a deteriorated structure of the extrudates.

2.3.3.3. Effect of oat β -glucan

Oat β -glucan is present both in oat flour and oat bran. It affects the physical properties of the extrudates. Yao *et al.* (2006) studied the physical properties of extrudates made from two oat flours with different β -glucan contents. One of the flours had a higher percentage (8.1%) of β -glucan compared to another one (4.8%). Decreased expansion was observed with higher β -glucan containing oat extrudates when the water content of the feed was increased. Extrudates made from the lower β -glucan oat flour had higher expansion due to the high amount of starch (*i.e.*, 63.3% compared to 54.4% in higher β -glucan oat flour). On the other hand, lower expansion of higher β -glucan extrudates might also be caused by the higher denaturation of proteins (Moraru and Kokini, 2003). The denaturation of protein means a destruction of both the secondary and tertiary structures of proteins. The hardness of the extrudates made from both flours was similarly affected by the temperature and the water content of the mass. The hardness of extrudates produced at the high extrusion temperature was lower. On the other hand, addition of higher amount of water during the extrusion resulted in increased hardness values (Yao *et al.*, 2006).

The extrusion at high temperatures and high shear conditions might also lead to a molecular fragmentation of β -glucan in oat flour, followed by possible inter-chain aggregations. The yield of soluble dietary fibre (SDF) from extruded oat bran has shown to be dependent on the moisture content of mass. For example, at 140 °C, the yields were

14.2, 12.6 and 11.5 g per 100 g sample at the water content of mass 10%, 20% and 30%, respectively. This was significantly higher than the yield of SDF from untreated oat bran, which was 8.9 g/100 g (Zhang *et al.*, 2011).

2.3.3.4. Effect of process variables

Physical properties of the oat containing extrudates were influenced by the process variables such as screw speed, water content of the mass and temperature. The significant effect of feed rate had not been found in the cited studies. Ozer *et al.* (2004) concluded that increased screw speed is a critical factor to obtain highly expanded oat flour extrudates. This is due to the fact that increasing screw speed tends to increase the shear forces inside the barrel and giving more developed and uniform mass. Also increasing the screw speed has decreased hardness thus promotes crispy texture (Liu *et al.*, 2000). Due to the high lipid content of oat flour, increased expansion was not observed with increasing screw speed (Ozer *et al.*, 2004; Liu *et al.*, 2000).

Water content of the mass was reported to affect mostly the expansion and hardness of extrudates. Single screw extruder requires more water for the lubrication. Twin-screw extruder is less dependent on water content of the mass. However, Wicklund (1995b) showed that when oat flour is used in extrusion, more water is required even with twin-screw extruder. In the study of Wicklund (1995b), low water content of the mass (15–18%) resulted poor expansion while higher water content up to 30% gave relatively more expanded extrudates. Liu *et al.* (2000) reported that when oat flour was used, water content of the mass had significant effect on expansion compared to the screw speed. They also showed that when the percentage of oat flour (55–100%) was increased in the mixture, the expansion ratio (2–4) increased with increasing water content of the mass (18–21%). High water content of the mass caused lower starch gelatinization and gave less expanded extrudates. However, in the case of oat flour the influence of water addition on expansion rate was related with the water binding effect of β -glucan and its indirect effect on viscosity. Moreover, high water content may also reduce the temperature of the mass as the friction between the screws and mass declines when water content increases. This interactive effect between the dough and screws may also be responsible for the poor starch gelatinization and may eventually lead to a reduced expansion of the product. Wicklund (1995a and 1995b) stated that the water content of the mass affected the bulk density when whole grain oat flour was used, but no significant effect was found for sifted oat flour. They also concluded that torque was significantly influenced by the water

content of the mass for both whole and sifted oat flour, while influence on the die pressure was small. Water content of the mass affects the porosity only at high screw speed. At high screw speed, porosity was found to increase with increasing water content of the mass.

Expansion properties depend mainly on the extrusion temperature and the amylose content of the starch. Singh *et al.* (1997) studied the relation of temperature and water content of the mass on the expansion rate. At 125 °C, the expansion of the extrudates decreased with increasing water content. However, at temperatures higher than 125 °C, expansion of the extrudates remained less affected and started to increase with increasing temperature. Some researchers suggested that extrusion temperature 160–180 °C is good to produce highly expanded extrudates from oat flour (Kokini *et al.*, 1992; Lobato *et al.*, 2010; Wicklund 1995a and Wicklund 1995b). Wicklund (1995a) reported that increasing the extrusion temperature decreased the bulk density when sifted oat flour was used.

Rzedzicki *et al.* (2000) showed that low screw speed and low water content might be able to give better physical properties to extrudates. They recommended that 9–12% oat bran could be added at low screw speed (100 rpm) and with low water content of the mass (13.5–14%) to obtain well expanded product. Rzedzicki *et al.* (2005) found out that more than 30% oat bran addition needs higher temperature (180–220 °C) even though the final product was found to be more compact due to the presence of high content of dietary fibres.

2.4. Conclusion of literature review

Based on several previous studies, it can be concluded that when using oat flour or oat bran in extrusion, it is quite difficult to obtain extrudates with desired physical properties. Extruded products from oat fractions are usually poorly expanded, hard and dense. Expansion and hardness of the extruded product depends on the composition and contents of the raw material and on several process variables. The high lipid and dietary fibre content of oat fractions are usually responsible for the poor physical properties of the oat-containing extrudates. However, the lower gelatinization temperature of oat starch could offer some beneficial aspects when mixing heat sensitive compounds, such as vitamins and proteins. Relatively low starch content of oat fractions, size and the quality of oat starch may also be responsible for poor physical properties of the extrudates. High amount of lipid content is responsible for low expansion and dense extrudates. Therefore, the removal of

lipids from the oat fractions would be needed. In addition, pure starch, such as corn starch, can be blended with oat fractions to get better expansion.

Along with raw material composition, process variables affect the physical properties of extrudates. The extrusion temperature has shown to have the greatest influence on the expansion and hardness of oat-containing extrudates. Increased temperature usually gave better physical properties. Generally, increasing screw speed increased the expansion and porosity of the extrudates. The screw speed had a different effect on the physical properties when oat bran and oat flour were used as raw materials. Lower screw speed gave better physical properties to the extrudates when oat bran was used in the experiments as it contains higher amount of dietary fibre than the oat flour. On the other hand, higher screw speed has shown to give better physical properties for oat flour. Water content of the mass had similar effect on the physical properties. Low water content of the mass gave better expansion for the extrudates made of oat bran and high water content of the mass for the extrudates made of oat flour. However, comparatively high water content might be needed for defatted oat flour to provide good lubrication effect inside the extruder barrel. There was no significant effect of the feed rate on the physical properties of the extrudates. However, in some cases the interactions of feed rate with the screw speed and the water content of the mass were found to be significant for the bulk density.

Optimization of the formulation together with the process variables are the two most critical factors to obtain extrudates with desired textural and physical characteristics. Defatted oat flour (30–50% of the mixture) can be used in extrusion by blending it with other cereal fractions. Extrusion temperature, water content of the mass and screw speed should be ranged between 130–180 °C, 16–30% and 200–500 rpm, respectively. To increase expansion and reduce hardness, other cereal fraction such as pregelatinised or waxy corn starch can be blended with the oat fractions.

3. EXPERIMENTAL RESEARCH

3.1. Aim

The aim of this study was to test different oat fractions and find out the effects of extrusion process variables (screw speed, water content of mass and feed rate) on the physical properties (expansion, hardness and water content) of the extrudates. Torque and pressure at the die was monitored during the extrusions. Defatted oat endosperm flour (EF) was used as the main ingredient and whole grain flour was used as reference. Defatted oat protein concentrate, defatted oat bran concentrate and two different corn starches (pregelatinised and waxy) were mixed with the EF. This study aimed to explain how the addition of different ingredients such as oat fractions and corn starch affects the physical and chemical properties of oat endosperm flour -based extrudates.

3.2. Overview of the study

Extrusion trial was the main experiment to determine the physical properties of extrudates. 9 separate extrusion trials were made to test different oat fractions. Chemical analysis was carried out to determine the β -glucan content of the extrudates. A flow diagram of the experimental study is shown in Figure 6.

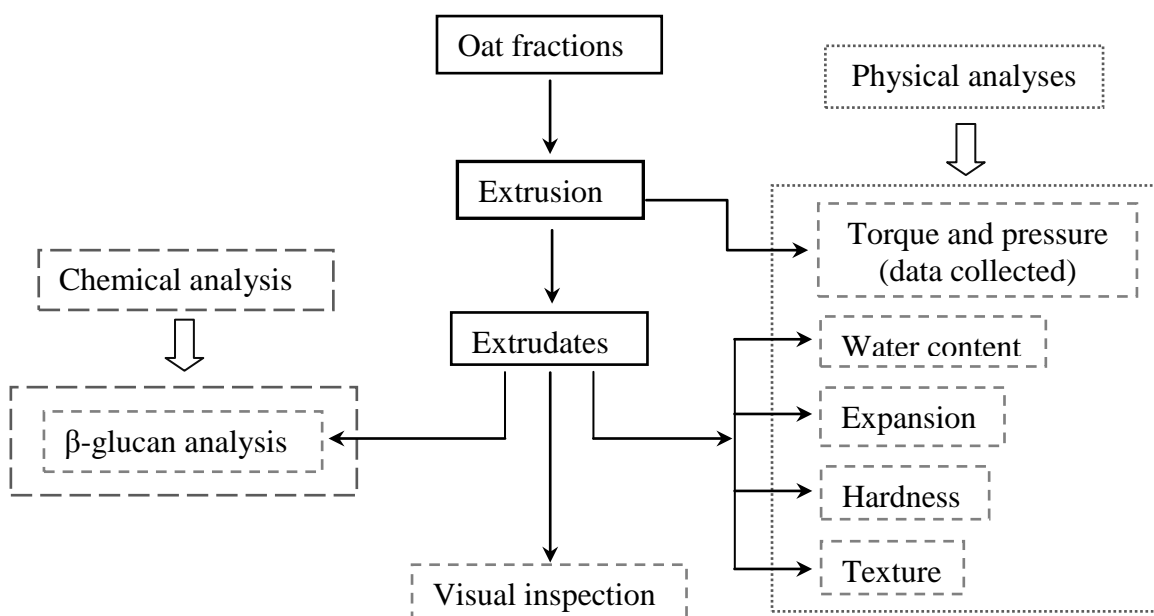

Figure 6. Flow diagram of the experimental design of this study

3.3. Material and methods

3.3.1. Extrusion materials

Extrusion trials were carried out by using defatted oat fractions such as endosperm flour (EF), whole grain flour (WF), bran concentrate (OBC, 213* μm), ultra-fine bran concentrate (UBC, 32* μm), enzyme-hydrolysed bran concentrate (EBC, 61* μm) and protein concentrate (PC). Oat flour containing starch (65%), protein (14.5%), lipids (5.7%) and 3.9% β -glucan was collected from a local flour mill (Riihikosken Vehnämylly, Pöytyä, Finland). Oat fractions for this study were defatted from oat flour by using supercritical carbon dioxide (SC-CO₂) extraction method developed by VTT Technical Research Centre of Finland. Endosperm flour and whole grain flour were used as main ingredients. To improve the nutritional quality of extrudates, different oat bran concentrates (Table 4) with 30% β -glucan and oat protein concentrate with 60% proteins were added to the extrusion masses (Table 4). To improve the expansion, pregelatinised corn starch (CS) containing 75% amylopectin and waxy corn starch (WS) containing 97% amylopectin was added with oat fractions in some trials. Pregelatinised and waxy corn starches were provided by Roquette Ltd., France. Salt (1% of solids) was used as an additive.

Table 4. Chemical composition of the raw materials (all oat fractions were defatted)

Name of the raw materials	Starch content (%)	Protein content (%)	Lipid content (%)	Fibre content (%)	β -glucan content (%)	Water content (%)	Particle size D ₅₀ * (μm)	β -glucan Mw (kDa)
Whole grain flour (WF)	65.6	17.2	2	6	4.9	8.7	98	1000
Endosperm flour (EF)	69.8	16.7	1.5	2.5	1.6	8.8	18	1000
Oat bran concentrate (OBC)	10	23.2	4.6	48.1	30	4.6	213	1000
Ultra-fine oat bran concentrate (UBC)	10	23.2	4.6	48.1	30	6.3	32	1000
Enzyme-hydrolysed oat bran concentrate (EBC)	10	23.2	4.6	48.1	30	9.6	61	50
Oat protein concentrate (PC)	17.1	62	2.8	2	1	1.7	n.a.	n.a.
Pregelatinised corn starch (CS)	98	n.a.	n.a.	n.a.	n.a.	4.7	n.a.	n.a.
Waxy corn starch (WS)	98	n.a.	n.a.	n.a.	n.a.	10.6	n.a.	n.a.

*D₅₀ values indicating that 50% of the particles have a diameter under a certain level, were analyzed with a Beckman Coulter LS 230 (Beckman Coulter, Inc., CA, USA) using the wet module with distilled water as a carrier
n.a.= not available

The chemical composition of the extrusion masses was calculated after mixing the raw materials (Table 5). Water contents of the raw materials were determined by taking 2 g of sample (in triplicate), drying them in an oven for 1 hour at 130 °C and cooling in a vacuum desiccator over phosphorus pentoxide (P₂O₅). After cooling, weight loss of the raw materials was measured by analytical balance (Presica Instrument Limited, Switzerland). Weight loss indicated the water content of the raw material. Water content of the raw materials was determined and taken into account in calculating the recipe (Appendix 1) of each extrusion trial.

Table 5. Amounts of different ingredients and calculated chemical composition of the mass

Trial	Composition of extrusion masses (%)								Starch content (%)	Protein content (%)	Lipid content (%)	Fibre content (%)	β-glucan content (%)
	EF	WF	OBC	UBC	EBC	PC	CS	WS					
1	100								69.8	16.7	1.5	2.5	1.6
2		100							65.6	17.2	2.0	6.0	4.9
3	90		10						64.0	17.3	1.8	6.9	4.4
4	90			10					63.8	17.4	1.8	7.1	4.4
5	90				10				63.8	17.3	1.8	6.9	4.3
6	90					10			64.9	21.0	1.6	2.5	1.5
7	50		20				30		66.4	13.0	1.7	10.7	6.7
8	50		20					30	67.0	12.8	1.6	10.5	6.6
9	40		20			10	30		61.0	17.5	1.8	10.7	6.7

3.3.2. Extrusion design

Extrusion trials with different recipes were carried out by using a co-rotating twin-screw extruder (Poly Lab System, Thermo Prism PTW24, Thermo Haake, Germany). Length (L) and diameter (D) of the screw was 672 mm and 24 mm respectively thus L/D was 28:1 (Figure 7). Extruder barrel consisted of 7 sections each of which was 96 mm long, where 6 had individual temperature control and heatable die of 5 mm diameter. Temperature profiles used in this study was 40, 70, 70, 100, 110, 130 and 130 °C in sections 1–6 and die, respectively. Temperature of the barrel was monitored by attached thermocouples, which supplied signals to the computer.

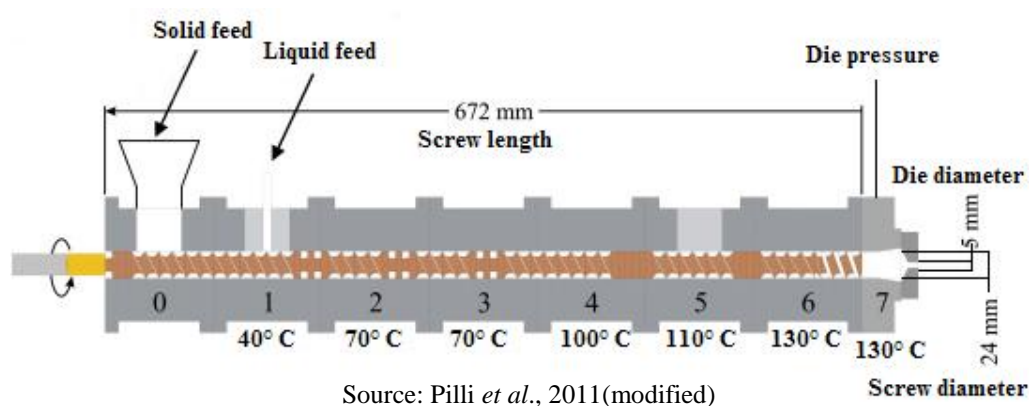

Figure 7. Screw configuration and barrel temperature used in extrusion to process oat-based extrudates

Extrusion trials (first 2) with endosperm flour and whole grain flour were made using Box-Behnken's experimental design (Table 6). Three independent variables of the Box-Behnken's design were: water content of the mass (16, 18 and 20%), screw speed (240, 370 and 500 rpm) and feed rate (68, 76 and 84 g/min). Water content of mass was controlled by adjusting the pump (Watson Marlow 505S, Watson Marlow Limited, Falmouth, Cornwall, England) to reach the desired value. During the extrusion processing, salt-water solution was pumped through rubber hose connected to the second section of the extruder barrel. In order to maintain the desired water content of the mass (16, 18 and 20%), feed rate of water was adjusted during the extrusion. Extrusion trials (1 and 2) with 100% endosperm flour and whole grain flour were done with the full experimental design. Remaining trials (3–9) were carried out with only experiment number 2 with highest screw speed (500 rpm), lowest water content of the mass (16%) and feed rate 76 g/min. Samples for each experiments were collected when extrusion process variables were reached to adjusted values and the conditions (torque and pressure) were stabilized. Torque and

pressure was monitored during the sample collecting time and data was collected during the experiment.

Table 6. Box-Behnken's experimental design was used in first 2 trials

Experiments	x_1	x_2	x_3	Water content of mass (%)	Screw speed (rpm)	Feed rate (g/min)
11	1	0	-1	20	370	68
3	-1	0	-1	16	370	68
5	0	-1	-1	18	240	68
7	0	1	-1	18	500	68
15	0	0	0	18	370	76
1	-1	-1	0	16	240	76
*2	-1	1	0	16	500	76
13	0	0	0	18	370	76
9	1	-1	0	20	240	76
10	1	1	0	20	500	76
14	0	0	0	18	370	76
6	0	-1	1	18	240	84
8	0	1	1	18	500	84
12	1	0	1	20	370	84
4	-1	0	1	16	370	84

Temperature profile: section 1-6 and die was 40, 70, 70, 100, 110, 130 and 130 °C

*Trial 3-9 were performed with only experiment 2

3.3.3. Analyses

3.3.3.1. Torque and pressure at the die

The values of torque and pressure at the die was monitored and collected during the extrusion. Calculation of the average with \pm SD (standard deviation) was done by Microsoft Office Excel, based on the torque and pressure at the die during the sample collecting time.

3.3.3.2. Physical properties of extrudates

Water content of the extrudates

Water content of the extrudates from different trials was determined by drying of samples (small pieces) at 50 °C in a vacuum oven (Salvis Vacucenter VC 50, Switzerland) for 72 hours and cooled (in a vacuum desiccator over phosphorus pentoxide, P₂O₅) for 1 hour before weighing dry weight by a balance (Presica Instrument Limited, Switzerland). The result was reported as an average of 2 replicates measurements for each experiment.

$$\text{Solid content} = \frac{\text{Weight (sample + beaker) after drying} - \text{Empty weight of beaker}}{\text{Weight (sample + beaker) before drying} - \text{Empty weight of beaker}}$$

$$\text{Water content \%} = 1 - \text{Solid content} \times 100$$

Expansion of the extrudates

Expansion of the extrudates was calculated by measuring the diameter from 1 point at the middle of the extrudates (10 replicates) from each experiment by using a vernier caliper. Samples were dried at 50 °C in a vacuum oven (Salvis Vacucenter VC 50, Switzerland) for 72 hours and cooled (in a vacuum desiccator over phosphorus pentoxide, P₂O₅) for 1 hour before measuring the diameter. The result was reported as an average of 10 replicate measurements for each experiment.

Expansion %

$$= \frac{\text{Diameter of extrudates mm} - \text{Diameter of die (mm)}}{\text{Diameter of die (mm)}} \times 100\%$$

Hardness of the extrudates

Hardness of the extrudates was determined by using universal testing machine under 3-point bending condition (Instron 4465, High Wycombe, United Kingdom). Hardness was also determined by using TA.XT2 Texture analyzer (Stable Micro System Ltd., Godalming, United Kingdom) under uniaxial compression condition. The results obtained from 2 different methods were compared. Extrudates were dried at 50 °C in a vacuum oven (Salvis Vacucenter VC 50, Switzerland) for 72 hours and cooled for 1 hour (in a vacuum desiccator over phosphorus pentoxide, P₂O₅) before measuring the hardness. The result was reported as an average of 5 replicate measurements for each experiment.

Hardness was expressed in terms of resistance per millimeter, when aluminium cross head (3 mm thick) penetration was perpendicularly enforced under 3-point bending condition (Figure 8). The radial breaking of the samples was made by placing them over a sample holder (distance between two holding points was 9 mm). The speed of aluminium cross head was 5mm/min. The force resisting the movement of the aluminum cross head was monitored. Data (force/distance) was collected during the hardness measurements and later plotted in a scattered chart by using Microsoft Excel. A linear trend line was fitted to the linear part of the data with higher correlation to determine the slope. The slope further expressed by N/mm.

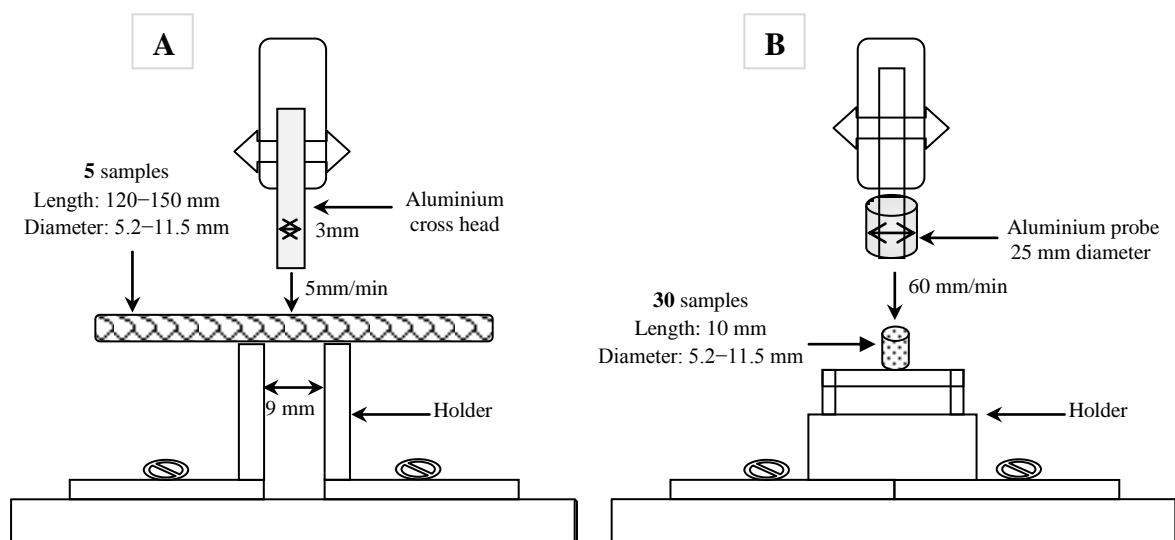

Figure 8. Schematic diagram of the hardness measurement by [A] 3-point bending condition and [B] uniaxial compression

Texture of the extrudates

Texture analysis by uniaxial compression (Figure 8) of the extrudates was determined by using TA.XT2 Texture analyzer (Stable Micro System Ltd., Godalming, United Kingdom) equipped with 5 kg load cell. Extrudates was dried at 50°C in a vacuum oven (Salvis Vacucenter VC 50, Switzerland) for 72 hours and cooled for 1 hour (in a vacuum desiccator over phosphorus pentoxide, P₂O₅). Samples of texture analysis (30 samples from each trial) were made by cutting the extrudates of 10 mm (axial section) length with an electric saw (Power ST-WBS800, Taiwan Sheng Tsai Industrial Company Limited, Taiwan).

Value of hardness, ratio of linear distance, crushing force and crispiness work was expressed in terms of resistance per millimeter, when the aluminium probe (25 mm diameter, cylinder) perpendicularly enforced under uniaxial compression condition. The samples were pressed by the aluminium probe with a constant rate of speed 60 mm/min with 70% strain (distance traveled by the probe). The force resisting the movement of the probe was monitored and the force deformation curve (Figure 9) was obtained to assess the mechanical characteristics of the extrudates samples. Hardness, ratio of linear distance, crushing force and crispiness work are calculated as following equations.

$$\text{Hardness} = F_{\max}$$

$$\text{Ratio of linear distance} = \frac{\text{Distance of actual curve}}{\text{Distance of smoothed curve}}$$

$$\text{Crushing force (N)} = \frac{\text{Area under the force deformation curve}}{\text{Distance traveled by the probe}}$$

$$\text{Crispiness work (Nmm)} = \frac{\text{Area below the force deformation curve}}{\text{Number of peaks}}$$

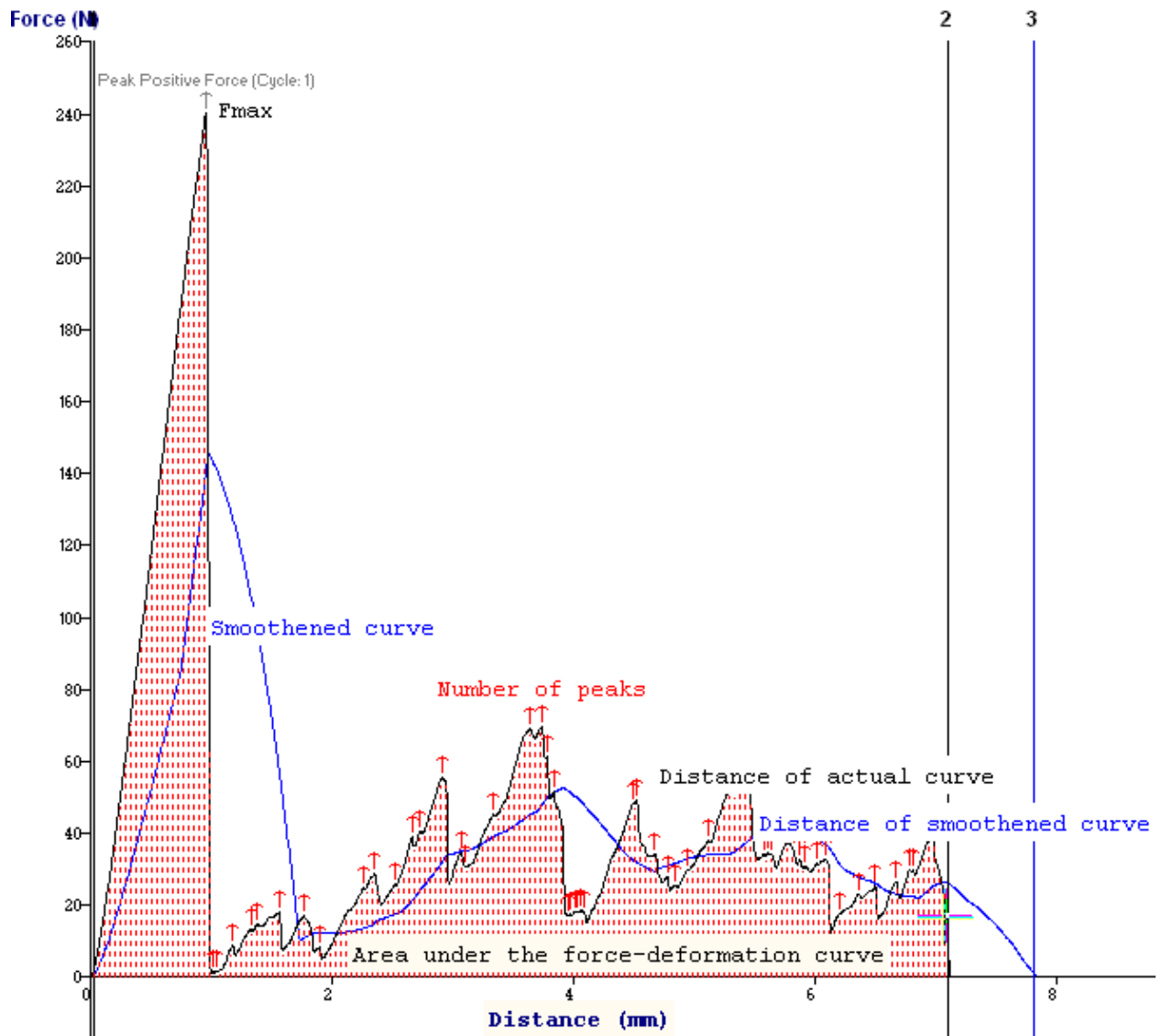

Figure 9. Force deformation curve obtained for 100% EF extrudates to assess the mechanical characteristics

3.3.3.3. Visual analysis of the extrudates

Visual inspection of the extrudates was done by taking images of the extrudates processed at same extrusion condition with experiment 2 (screw speed = 500 rpm, water content of mass = 16% and feed rate = 76 g/min). An electric saw (Power ST-WBS800, Taiwan Sheng Tsai Industrial Co. Ltd. Taiwan) was used to cut the extrudates of about 15 mm (longitudinal section) and 5 mm (axial section). Longitudinal section was further made by cutting the samples through the middle of the diameter. A millimeter scale was used in the background of the sample to show the expansion and size of the pores. Images were taken from a constant distance (15 cm from the objective lens) by AxioCam MRC, Carl Zeiss digital camera equipped with auto macro Olympus Zuiko objective (9–18mm f/4–5.6 lens for Olympus, Tokyo, Japan). For the image processing, Axiovision 3.1 software by Carl

Zeiss Inc. was used. Images were cropped at 100% magnification by using Microsoft Office.

3.3.3.4. β -glucan analysis

The β -glucan content was determined by the spectroscopic method 32-23.01 (AACC, 1999) using the Megazyme β -glucan mixed linkage assay kit (Megazyme International Ireland Ltd., Wicklow, Ireland). Extrudates from experiment 2 of each trial (in total 9) were grounded at 12000 rpm using ultra centrifugal milling equipment (Retsch ZM 200, Haan, Germany). About 50 mg of ground samples and similar amount of standard S1, Megazyme (1-3) (1-4) β -glucan for barley flour control (4.1% β -glucan) and standard S2, Megazyme (1-3) (1-4) β -glucan for oat flour control (8.8% β -glucan) were also weighed. Duplicates were made for each sample as well as the standards.

3.3.3.5. Statistical analyses

Regression analysis (trials 1 and 2) was performed using Matlab program (The MathWorks, Inc., USA) and the response surface plots were made. Regression analysis was used to show the effect of extrusion process variables (screw speed, feed rate and water content of mass) on the response variables (torque and pressure at the die during extrusion, water content, expansion and hardness of extrudates). Coded values (-1, 0 and +1 to represent coded screw speed) were used to made response surface plots according to the regression models. The plots were graphically represented with the real values (*e.g.*, 240, 370 and 500 rpm to represent actual screw speed) and the effect of extrusion process variables (by placing them in X and Z axes) on the response variable (by placing in Y axis).

The correlation between response variables (expansion, hardness and water content of extrudates, torque and pressure at the die) was calculated by PASW statistics (Version 17, SPSS Inc., Chicago, Illinois). The data were statistically processed at LSD ($p < 0.01$ and $p < 0.05$).

The significance test of the average of the response variables (expansion, hardness and water content of the extrudates) were done to compare the properties of extrudates obtained from experiment 2. Statistical analysis was done by analysis of variance and LSD ($p < 0.01$) by PASW statistics (Version 17, SPSS Inc., Chicago, Illinois).

3.4. Results

3.4.1. Torque

Regression analysis showed that torque was significantly affected by screw speed ($p < 0.001$), when using 100% EF or WF (Table 7): increased screw speed decreased torque (Figure 10). Regression model presented significant regression for both EF ($p < 0.001$) and WF ($p < 0.01$) and insignificant lack of fit ($p > 0.05$). Significant negative effect of the water content of mass on torque ($p < 0.05$) was found for 100% WF: increased water content of the mass decreased torque (Table 7).

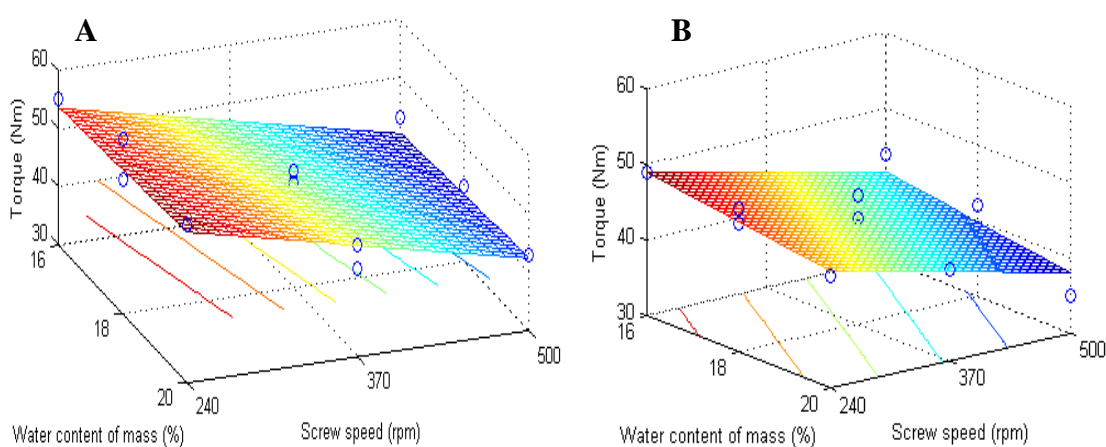

Figure 10. Response surface plots of the effects of water content of the mass and screw speed on the torque during extrusion of EF (A) and WF (B)

During extrusion trial of 100% EF and 100% WF, torque was varied depending on the water content of the mass and screw speed. The torque was 43–60 Nm and 35–49 Nm for EF and WF, respectively. In both trials, lowest torque was obtained at highest screw speed and with highest water content of the mass. Addition of OBC did not affect torque but the addition of UBC and EBC lowered the torque a little bit (Table 8). The lowest torque was obtained among all trials when 30% WS added with EF and OBC.

3.4.2. Pressure at the die

Regression analysis showed that pressure was negatively affected the water content of the mass ($p < 0.001$) when using 100% EF or WF: increased water content of the mass led to decreased pressure (Figure 11). Pressure was also negatively affected by the screw speed for both EF ($p < 0.001$) and WF ($p < 0.05$). Regression model presented significant regression ($P < 0.001$) for both EF and WF and insignificant lack of fit ($p > 0.05$). However, significant effect of feed rate ($p < 0.01$) was also found for the extrudates containing EF: increasing feed rate increased pressure at the die (Table 7).

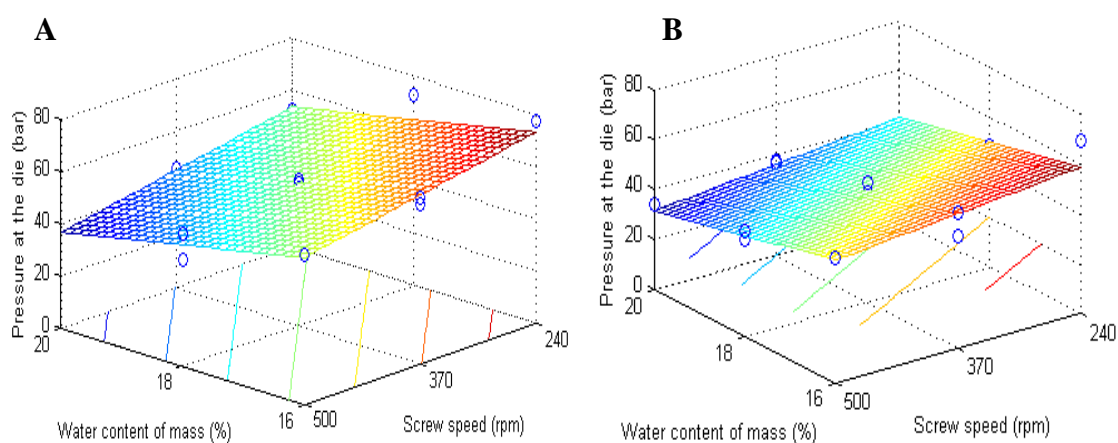

Figure 11. Response surface plots of the effects of water content of the mass and screw speed on the pressure at the die during extrusion of EF (A) and WF (B)

During extrusion trials of 100% EF and WF, pressure was also varied depending on the water content of the mass and screw speed. The pressure was 41–78 bar and 34–69 bar with 100% EF and 100% WF, respectively. In both trials, lowest pressure was observed with highest screw speed and with highest water content of the mass. Addition of OBC did not affect pressure, but the addition of ultra-fine OBC and enzyme-hydrolysed OBC lowered the pressure (Table 8). Pressure at the die was lower with the addition of 30% CS than with 30% WS. The lowest pressure (28 bar) was observed when 30% CS was added in the mixture of 40% EF, 20% OBC and 10% PC.

Table 7. Coefficients of variable estimates from the regression models of the extrudates containing oat endosperm flour (EF) and whole grain flour (WF)

Oat fraction	Independent extrusion variables	Response variables				
		Expansion (%)	Hardness (N/mm)	Water content (%)	Torque (Nm)	Pressure (bar)
EF	Water content of the mass (%)	-10***	11.25	1.78***	1.13	-9.88***
	Screw speed (rpm)	27.75***	-27.5*	-1.21***	-6.63***	-8.63***
	Feed rate (g/min)	4.25	-1.25	0.04	1.50	4.50**
	Intercept	61.27***	176.67***	11.71***	48***	55***
	R ²	94.40	38.59	94.24	80.69	92.20
	P (lack of fit)	0.376	0.002	0.406	0.645	0.151
WF	Water content of the mass (%)	-7.25***	-7.50*	2.01***	-1.75*	-8.75***
	Screw speed (rpm)	13.25***	-23.75***	-1.25***	-3.75***	-4.88*
	Feed rate (g/min)	-1.00	-3.75	0.66**	0.75	-0.88
	Intercept	25.60***	195.33***	13.40***	43.53***	45.13***
	R ²	96.50	84.96	95.20	74.60	78.10
	P (lack of fit)	0.279	0.678	0.235	0.589	0.320
	Water content of the mass (%) × Screw speed (rpm)	-2.75*	n.a.	n.a.	n.a.	n.a.

Extrusion variables with significant effect on the response variables *p < 0.05; **p < 0.01; ***p < 0.001
n.a. = not available

Table 8. Values of response variables in different extrusion trials at same extrusion condition: water content of the mass = 16%, screw speed = 500 rpm and feed rate = 76 g/min

Trial	Mixture composition (%)								Torque (Nm)	Pressure (bar)	Water content (%)	Expansion (%)	Hardness (N/mm)
	EF	WF	OBC	UBC	EBC	PC	CS	WS					
1	100								43 ± 1	57 ± 9	9.2 ± 0.3 ^a	99 ± 8 ^a	120 ± 50 ^{abcdefgi}
2		100							44 ± 1	50 ± 9	9.7 ± 0.1 ^b	51 ± 4 ^b	170 ± 30 ^{abcdef}
3	90		10						44 ± 2	58 ± 6	10.3 ± 0.1 ^{bc}	72 ± 5 ^c	140 ± 70 ^{abcdef}
4	90			10					40 ± 1	47 ± 7	11.6 ± 0.0 ^d	76 ± 2 ^c	150 ± 40 ^{abcdef}
5	90				10				38 ± 1	39 ± 7	12.5 ± 0.0 ^e	71 ± 3 ^c	130 ± 20 ^{abcdefgi}
6	90					10			41 ± 2	53 ± 8	10.5 ± 0.2 ^{cg}	83 ± 6 ^d	130 ± 30 ^{abcdefi}
7	50		20				30		42 ± 2	32 ± 7	11.0 ± 0.1 ^{fg}	101 ± 5 ^a	60 ± 10 ^{aeghi}
8	50		20					30	36 ± 1	39 ± 7	10.8 ± 0.1 ^{fg}	128 ± 4 ^e	60 ± 10 ^{ghi}
9	40		20			10	30		42 ± 2	28 ± 6	11.1 ± 0.3 ^{dfg}	91 ± 3 ^f	80 ± 20 ^{aefghi}

EF = Endosperm flour, WF= Whole grain flour, OBC = Bran concentrate, UBC = Ultra-fine bran concentrate, EBC = Enzyme-hydrolysed bran concentrate, PC = Protein concentrate, CS = Pregelatinised corn starch and WS = Waxy corn starch.

The values marked with different letters in a column were significantly different at the level 0.01

3.4.3. Water content of the extrudates

Regression analysis showed that water contents of extrudates were significantly affected by screw speed ($p < 0.001$) and water content of the mass ($p < 0.001$) for both 100% EF and 100% WF extrudates (Table 7). The regression model presented significant regression ($p < 0.001$) and insignificant lack of fit ($p > 0.05$) for the extrudates containing EF and WF. Screw speed had a negative effect on the water content of extrudates: increased screw speed decreased water content of the mass (Figure 12). In 100% WF extrudates, the water content of the extrudates was significantly increased with increased feed rate ($p < 0.01$).

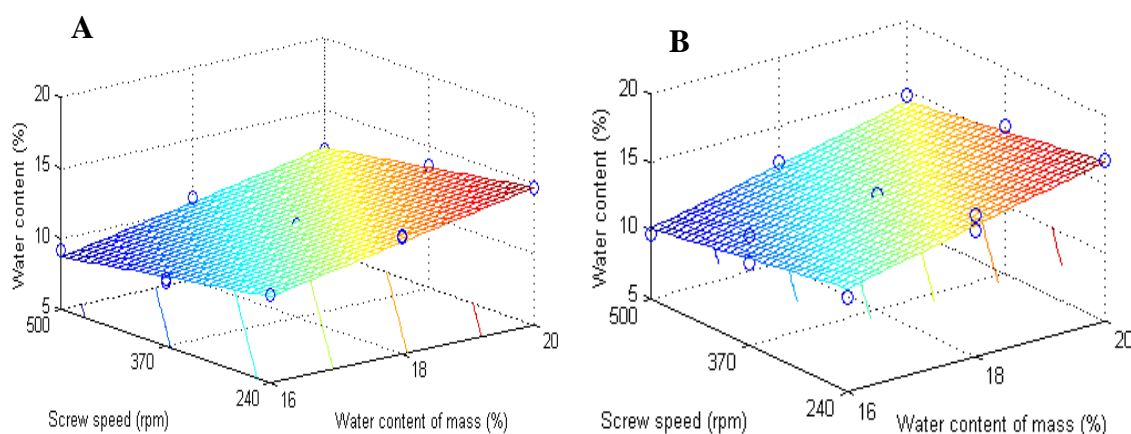

Figure 12. Response surface plots of the effects of screw speed and water content of the mass on the water content of the extrudates containing EF (A) and WF (B)

Water content of the 100% EF extrudates (Table 7) varied depending on the water content of the mass. When water content of the mass was 16, 18 and 20%, water content of the extrudates varied between 9.2–11.3%, 10.8–13.6% and 12.1–14.7%, respectively. For 100% WF extrudates (Table 8), the respective values were: 9.7–13%, 11.6–15.4% and 14.5–16.8%.

Water content of the extrudates was 10.3 and 10.5% when 10% OBC or 10% PC was added to the 90% EF mixture with 16% water content (experiment 2). Increased water content of the extrudates (11.6% and 12.6%) was found when 10% UBC or 10% EBC was added. Water content of the extrudates was 10.8% or 11.0% when 30% WS or 30% CS was added to 50% EF and 20% OBC, respectively (Table 8).

3.4.4. Expansion of the extrudates

Regression analysis showed that expansion was significantly affected by the screw speed ($p < 0.001$) and water content of the mass ($p < 0.001$) in both trials with 100% EF and 100% WF. The regression model presented significant regression ($p < 0.001$) and insignificant lack of fit ($p > 0.05$) for both trials (Table 7). There was no influence of the feed rate ($p > 0.05$) on expansion for both EF and WF extrudates. Increased amount of water content of the mass decreased the expansion of the 100% EF and WF extrudates. Highest expansion was achieved with highest screw speed in both trials (Figure 13). An interaction was found between the water content of the mass and screw speed ($p < 0.05$) for the expansion of the WF extrudates.

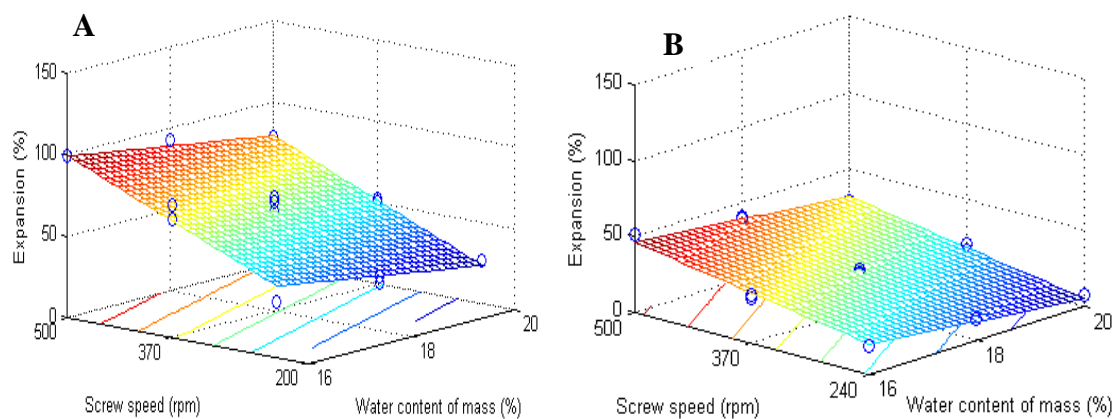

Figure 13. Response surface plots of the effects of screw speed and water content of mass on the expansion of the extrudates made of EF (A) and WF (B)

The extrudates made of 100% WF gave about half of the expansion compared to the EF (Figure 16 and 17). The expansion of the extrudates made of EF and WF varied between (29–99%) and (7–51%) respectively (data shown in appendix 2 and 3). The maximum expansion of the extrudates made of EF and WF was achieved in experiment 2, with the lowest water content of the mass (16%), highest screw speed (500 rpm) and feed rate (76 g/min). The expansion of EF extrudates was almost double compared to WF (99% vs. 51% in Table 8). Addition of 10% oat bran concentrate (OBC) and oat protein concentrate (PC) to EF decreased the expansion in experiment 2 (Table 8). The expansion was lower (72%) with the addition of OBC compared to the addition of PC (83%). However, the particle size reduction or enzymatic hydrolysis of OBC did not significantly affect the expansion (71 and 76% respectively).

Addition of 30% corn starch increased the expansion of the extrudates. The increase in expansion was higher with waxy corn starch (128%) than with pregelatinised corn starch (101%). Reduced expansion (91%) was observed when 10% PC was added with 40% EF, 30% pregelatinised corn starch (CS) and 20% OBC (Table 8).

3.4.5. Hardness of the extrudates

The regression model presented significant regression ($p < 0.001$) and insignificant lack of fit ($p > 0.05$) for 100% WF extrudates, while insignificant regression ($p > 0.05$) and significant lack of fit was found for 100% EF extrudates. Screw speed had the most significant negative effect ($p < 0.001$) on the hardness of the WF extrudates: increased screw speed decreased the hardness (Figure 14). Hardness of WF extrudates was also significantly affected by the water content of the mass ($p < 0.05$), increased water content of mass decreased hardness. There was no effect of feed rate on the hardness of WF extrudates (Table 7).

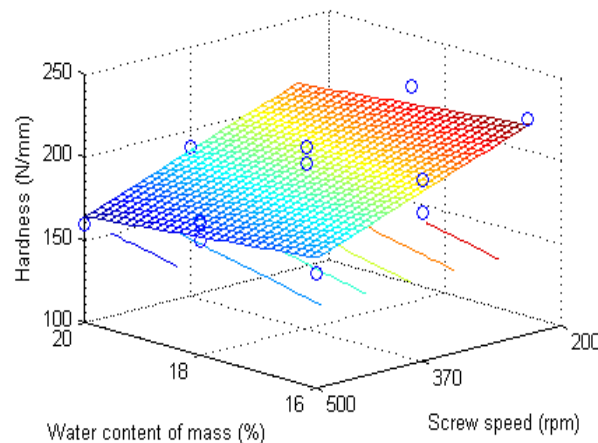

Figure 14. Response surface plots of the effects of screw speed, water content of mass on the hardness of the extrudates made of WF

The hardness of the extrudates made of 100% EF or WF (appendix 2 and 3) varied between 120–280 N/mm and 160–230 N/mm respectively. The lowest hardness of the extrudates made of 100% EF was achieved in experiment 2, which had the highest screw speed (500 rpm) lowest water content of the mass (16%) and moderate feed rate (76 g/min). On the other hand, lowest hardness for WF extrudates was achieved in experiment 10, which was carried out using highest screw speed (500 rpm), water content of the mass (20%) and moderate feed rate (76 g/min). Therefore, in both 100% EF and WF extrudates, the highest screw speed gave the lowest hardness.

Addition of 10% PC or OBC into 90% EF increased the hardness (130 and 140 N/mm) of the extrudates. The use of ultra-fine bran concentrate (UBC) and enzyme-hydrolysed bran concentrate (EBC) did not significantly affect the hardness (Table 8).

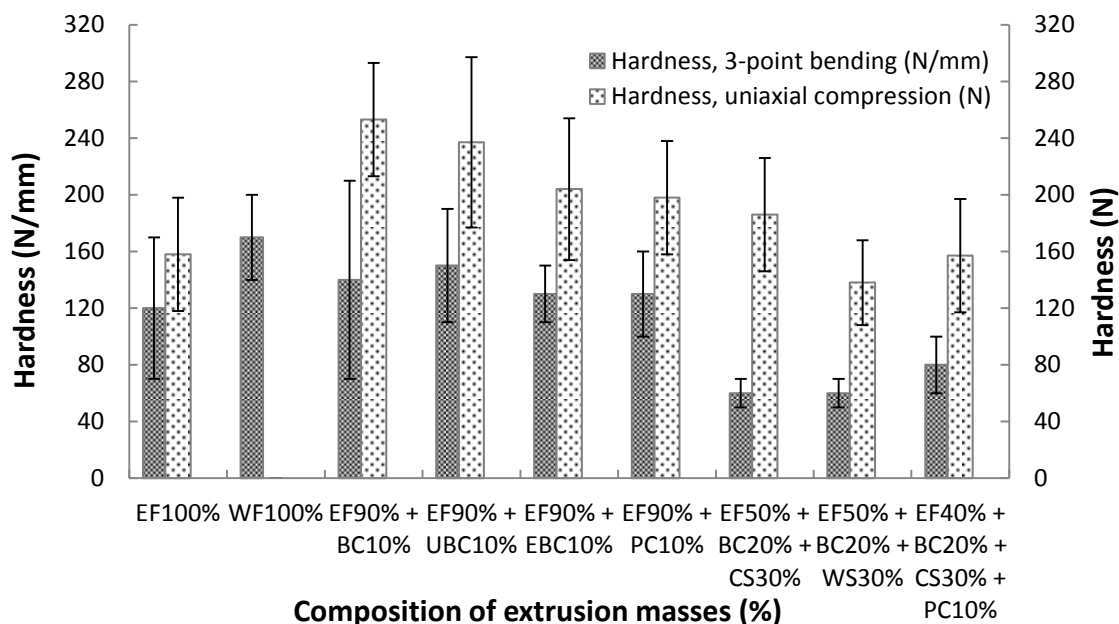

Figure 15. Hardness values obtained from 3-point bending condition and uniaxial compression. Samples were collected from experiment 2 and error bar shows (\pm) standard deviations.

Reduced hardness was achieved when 30% CS or WS was added into 50% EF and 20% OBC. Addition of CS or WS reduced the hardness to 60 N/mm. However, hardness of the extrudates increased to 80 N/mm, when 10% of PC was mixed with 30% of CS, 20% of OBC and 40% of EF (Table 8).

The standard deviation of the hardness value obtained with 3-point bending condition was high. Only 5 replicates were used for each experiment to measure the hardness of the extrudates. Hardness of the extrudates also measured under uniaxial compression method with 30 replicates to compare the results obtained with 3-point bending condition. Like 3-point bending, extrudates made of 100% EF were less hard than the extrudates made of 100% WF. WF samples were too hard to analyze with texture analyzer but under 3-point bending condition, it was possible to analyze all the WF samples even though they were the hardest samples (Figure 15).

According to the uniaxial compression the hardness values declined with the addition of bran concentrate (OBC > UBC > EBC), but with 3-point bending, there was no effect of UBC and EBC on the hardness of extrudates (Table 9). However, high standard deviation

was still present in the hardness values obtained with uniaxial compression. Addition of 30% WS gave less hard extrudates compared to the addition of 30% CS into EF-based extrudates. On the other hand, addition of CS and WS both gave similar results. However, addition of 10% PC with into EF-based extrudates increased the hardness in both measurement condition (Figure 15).

Table 9. Values of texture analysis from different extrusion trials at same extrusion condition: water content of the mass = 16%, screw speed = 500 rpm and feed rate = 76 g/min

Trial	Mixture composition (%)								Hardness (N)	Ratio of linear distance	Crushing force (N)	Crispiness work (Nmm)
	EF	WF	OBC	UBC	EBC	PC	CS	WS				
1	100								158 ± 40	3.5 ± 1	27 ± 10	3 ± 1
2		100							n.a.	n.a.	n.a.	n.a.
3	90		10						253 ± 40	2.2 ± 1	31 ± 20	39 ± 50
4	90			10					237 ± 60	2.6 ± 1	31 ± 20	29 ± 50
5	90				10				204 ± 50	2.3 ± 1	14 ± 10	36 ± 40
6	90					10			198 ± 40	3.0 ± 1	20 ± 10	13 ± 30
7	50		20				30		186 ± 40	3.2 ± 1	24 ± 10	9 ± 20
8	50		20					30	138 ± 30	4.0 ± 1	26 ± 10	1 ± 1
9	40		20			10	30		157 ± 40	3.0 ± 1	13 ± 5	8 ± 10

n.a. = not available (samples were too hard to analyze, texture analyzer stopped working during the measurements)

EF = Endosperm flour, WF= Whole grain flour, OBC = Bran concentrate, UBC = Ultra-fine bran concentrate, EBC = Enzyme-hydrolysed bran concentrate, PC = Protein concentrate, CS = Pregelatinised corn starch and WS = Waxy corn starch

Table 10. Coefficients of correlation between the mechanical properties of oat containing extrudates

Mechanical Properties	Hardness ^a (N)	Ratio of linear curve	Crushing force (N)	Crispiness work (N/mm)	Hardness ^b (N/mm)
Hardness ^a (N)	1	-0.819*	0.232	0.891**	0.752*
Ratio of linear curve		1	-0.181	-0.877**	-0.706
Crushing force (N)			1	0.017	0.259
Crispiness work (N/mm)				1	0.719*
Hardness ^b (N/mm)					1

*Correlation is significant at the level 0.05. **Correlation is significant at the level 0.01

a = hardness under uniaxial compression; b = hardness under 3-point bending condition

Texture of the extrudates

The data from texture analyzer showed that hardness of the extrudates increased when 20% oat bran concentrates (OBC, UBC and EBC) added with EF (Table 9). Addition of waxy corn starch gave the lowest hard extrudates. It is clear that reduced hardness was found with the addition of oat bran concentrates (OBC > UBC > EBC). There was a correlation found between hardness and crispiness work of the extrudates made from oats (Table 10). Crispiness work of the extrudates was increased with hardness by uniaxial compression ($p < 0.01$) and 3-point bending condition ($p < 0.05$). The less crispy extrudates was obtained with the addition of waxy corn starch, while addition of bran concentrates increased the crispiness work.

3.4.6. Visual analyses of the extrudates

The visual inspection of extrudates was done from the samples of 9 separate trials, processed at the same extrusion conditions (experiment 2: screw speed 500 rpm, water content of the mass 16% and feed rate 76 g/min). The changes in physical attributes of the examined samples varied depending on the raw materials used. The images of the axial cross-section of extrudates showed that the size and shape depended on the pore distribution inside the extrudates (Figure 16).

Extrudates made of 100% WF were less porous compared to the extrudates made of 100% EF. Therefore, WF extrudates were dark in colour, dense, less expanded and hard compared to EF extrudates. Addition of 10% bran concentrate (OBC, particle size: 213 μ m), ultra-fine bran concentrate (UBC, particle size: 32 μ m) and enzyme-hydrolysed bran concentrate (EBC) decreased the pore size and made the extrudates less expanded and harder compared to 100% EF. In both axial and longitudinal cross-section images (Figure 16, 17), there were no significant differences in the pore size of the extrudates made by adding different bran concentrate (OBC, UBC or EBC) into EF. Addition of 10% protein concentrate (PC) decreased the pore size of EF extrudates. In addition, the pores were not evenly distributed compared to EF extrudates. Therefore, the shape of the extrudates was affected and extrudates were not straight anymore (Figure 16, 17). Addition of pregelatinised corn starch (CS, 75% amylopectin) and waxy corn starch (WS, 97% amylopectin) increased the pore size and gave a lighter colour to the extrudates. Although 20% OBC was added, the size and number of the pores increased when CS or WS were added. Extrudates containing WS (Figure 16, 17) were more porous compared to those

with CS (Figure 16, 17). Addition of 10% protein with 30% CS decreased the pore size but pores were evenly distributed to the axial and longitudinal structure (Figure 16, 17). Extrudates containing 30% CS and WS were light in colour (yellowish) compared to other extrudates (more brown). It was noticeable that during the cutting of extrudates, it was difficult to have a clear-cut samples containing corn starch (CS and WS), due to the increased brittleness of the extrudates.

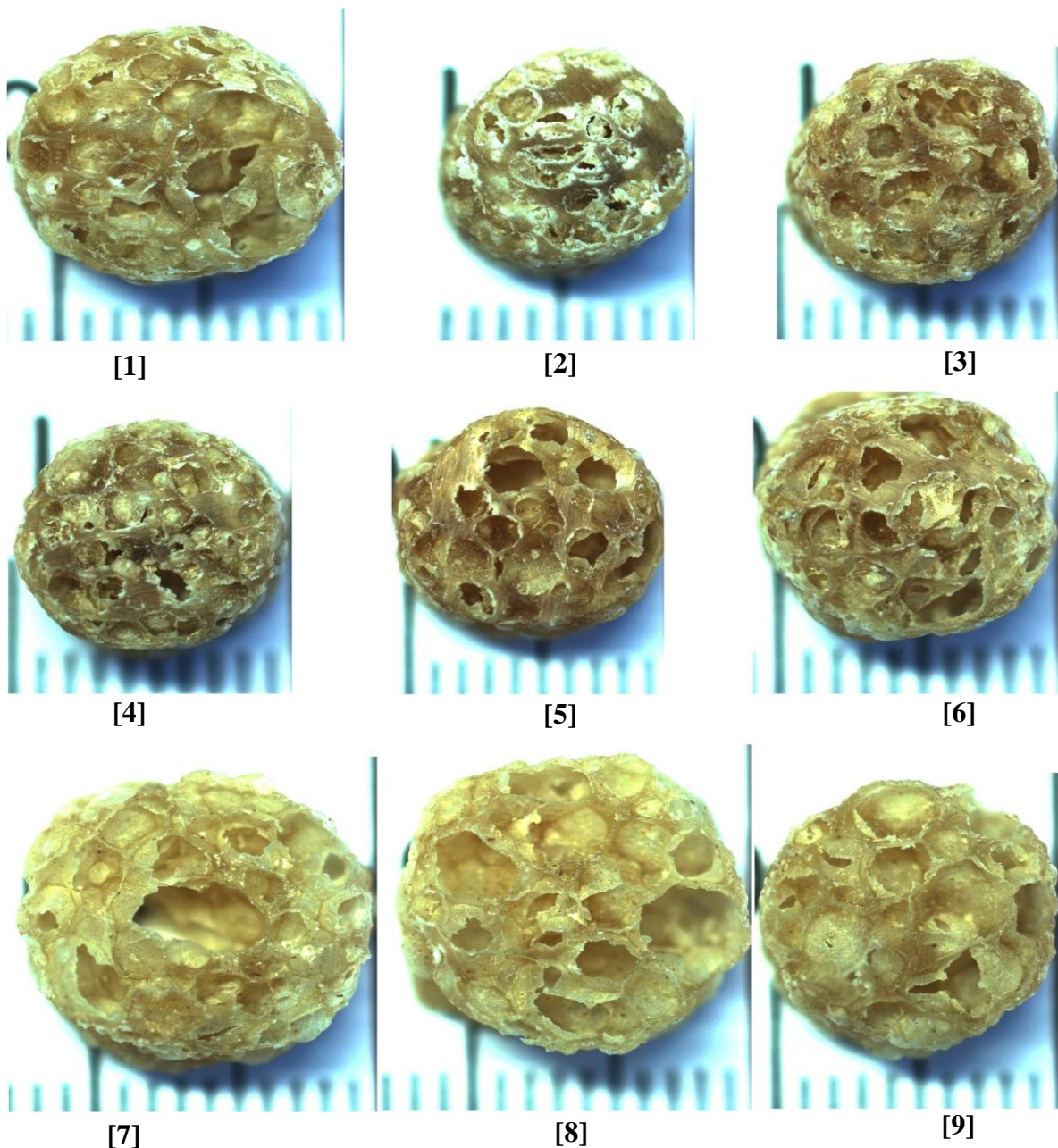

Figure 16. Extrudates from 9 trials at same extrusion condition (exp. 2: screw speed=500 rpm, water content of mass=16% and feed rate=76 g/min). The recipes of the samples were: [1] EF (100%), [2] WF (100%), [3] EF (90%) + OBC (10%), [4] EF (90%) + UBC (10%), [5] EF (90%) + EBC (10%), [6] EF (90%) + PC (10%), [7] EF (50%) + OBC (20%) + CS (30%), [8] EF (50%) + OBC (20%) + WS (30%), [9] EF (40%) + OBC (20%) + WS (30%) + PC (10%)

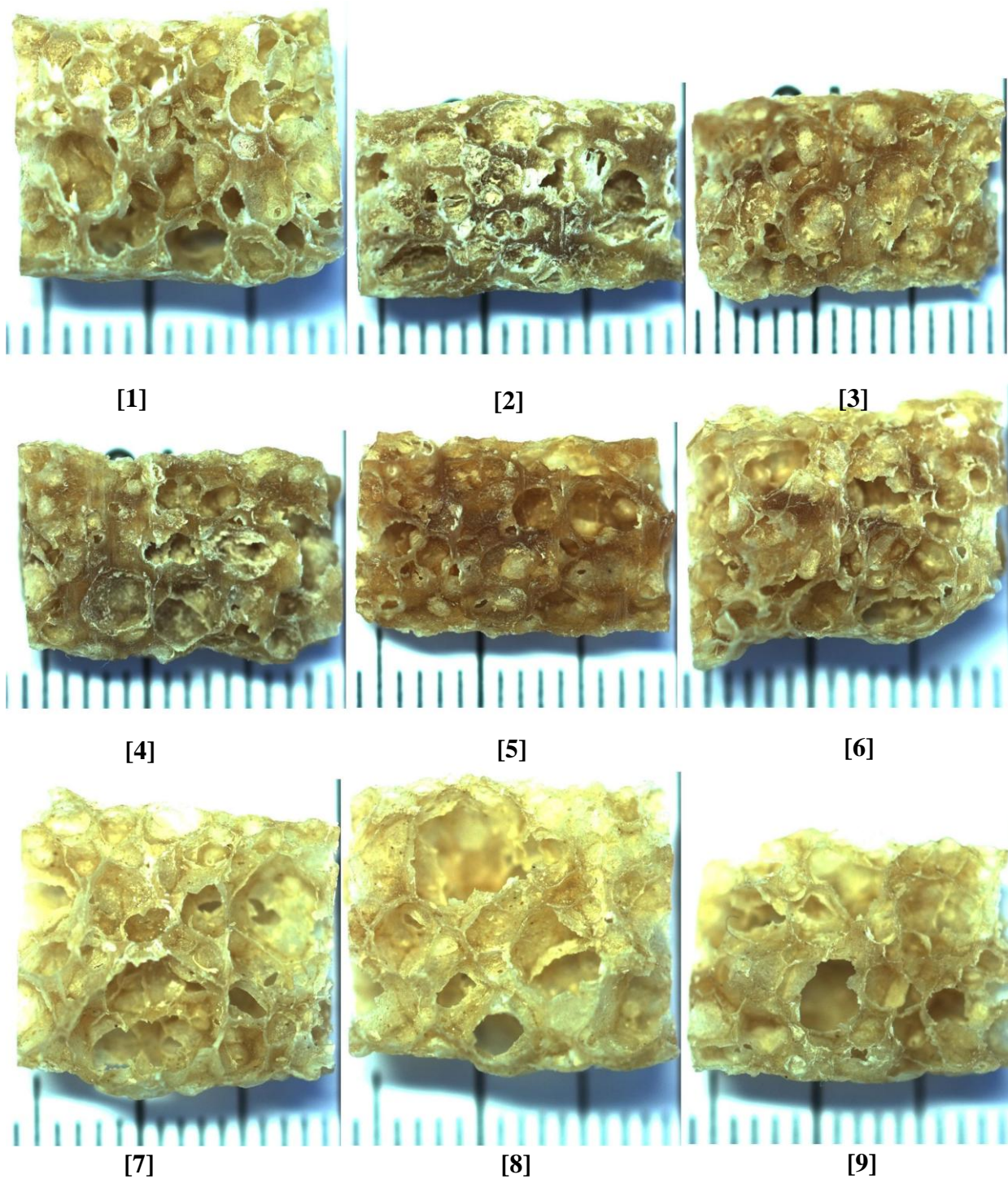

Figure 17. Extrudates from 9 trials at same extrusion condition (exp. 2: screw speed=500 rpm, water content of mass=16% and feed rate=76 g/min). The recipes of the samples were:
 [1] EF (100%), [2] WF (100%), [3] EF (90%) + OBC (10%), [4] EF (90%) + UBC (10%), [5] EF (90%) + EBC (10%), [6] EF (90%) + PC (10%), [7] EF (50%) + OBC (20%) + CS (30%), [8] EF (50%) + OBC (20%) + WS (30%), [9] EF (40%) + OBC (20%) + WS (30%) + PC (10%)

3.4.7. β -glucan analysis

The β -glucan analysis showed that EF extrudates with 20% added oat bran concentrate had the highest β -glucan content, 7.1–7.4%, whereas 100% EF extrudates had the lowest β -glucan content, 1.5% (Table 11).

Addition of 10% oat protein concentrate (PC) did not significantly increase the β -glucan content of extrudates. Whole grain flour (WF) alone provided high β -glucan content to the extrudates. Addition of 10% of oat bran concentrate (OBC, UBC or EBC) increased the β -glucan content up to 4.6–4.9% (dry weight). In trial 8, when 20% OBC and 30% WS was added with EF, the most expanded and less hard extrudates were obtained with the high β -glucan content.

Table 11. Values of β -glucan content in the extrudates from different trials at same extrusion condition: water content of the mass = 16%, screw speed = 500 rpm and feed rate = 76 g/min

Trial	Mixture composition (%)								β -glucan of weight (%)	Water content (%)	Dry weight (%)	β -glucan of dry weight (%)
	EF	WF	OBC	UBC	EBC	PC	CS	WS				
1	100								1.3 \pm 0.0	9.2	90.8	1.5
2		100							4.7 \pm 0.2	9.7	90.3	5.2
3	90		10						4.2 \pm 0.3	10.3	89.7	4.6
4	90			10					4.4 \pm 0.1	11.6	88.4	4.9
5	90				10				4.1 \pm 0.1	12.5	87.5	4.7
6	90					10			1.6 \pm 0.0	10.5	89.5	1.8
7	50		20				30		6.3 \pm 0.1	11.0	89.0	7.1
8	50		20					30	6.6 \pm 0.1	10.8	89.2	7.4
9	40		20			10	30		6.4 \pm 0.0	11.1	88.9	7.2
Standard 1: Megazyme (1-3) (1-4) β -glucan, barley flour control, 4.1% β -glucan									3.7 \pm 0.2	10.9	89.1	4.2
Standard 2: Megazyme (1-3) (1-4) β -glucan, oat flour control, 8.8% β -glucan									8.2 \pm 0.3	10.7	89.3	9.2

EF = Endosperm flour, WF= Whole grain flour, OBC = Bran concentrate, UBC = Ultra-fine bran concentrate, EBC = Enzyme-hydrolysed bran concentrate, PC = Protein concentrate, CS = Pregelatinised corn starch and WS = Waxy corn starch

3.4.8. Correlations

The response variables of the extrudates containing 100% EF and 100% WF were statistically analyzed to find the correlation (Table 12). Torque presented correlation with all the response variables in 100% EF trial. All the response variables increased with increasing torque except expansion. Water content of the extrudates showed negative correlation with expansion of the extrudates containing 100% EF ($p < 0.01$): increased water content of the mass decreased expansion. However, a negative correlation ($p < 0.05$) was also present between expansion and hardness.

Hardness showed positive correlation with torque and pressure ($p < 0.01$). Therefore, increased torque and pressure at die increased the hardness of the 100% WF extrudates. Like 100% EF, extrudates containing 100% WF showed negative correlation between expansion and water content of the extrudates ($p < 0.01$). Hardness also negatively correlated with expansion, which means increased expansion always tend to decrease the hardness of the extrudates.

Table 12. Coefficients of correlation between different response variables of the extrudates containing oat endosperm flour (EF) and whole grain flour (WF)

Oat Fraction	Response variables	Torque (Nm)	Pressure (bar)	Water content (%)	Expansion (%)	Hardness (N/mm)
EF	Torque (Nm)	1	0.540*	0.635*	-0.847**	0.593*
	Pressure (bar)		1	-0.208	-0.296	0.192
	Water content (%)			1	-0.792**	0.498
	Expansion (%)				1	-0.592*
	Hardness (N/mm)					1
WF	Torque (Nm)	1	0.668**	0.051	-0.439	0.758**
	Pressure (bar)		1	-0.499	-0.004	0.643**
	Water content (%)			1	-0.835**	-0.026
	Expansion (%)				1	-0.638*
	Hardness (N/mm)					1

*Correlation is significant at the 0.05 level, **Correlation is significant at the 0.01 level

3.5. Discussion

3.5.1. Effect of raw material on the physical properties of extrudates

3.5.1.1. Effect of different oat fractions

Addition of oat bran decreased the expansion of the extrudates made of EF. Rzedzicki *et al.* (2000) showed that addition of oat bran decreased the expansion of corn based extrudates when extruding a mixture of oat bran and corn semolina. According to Liu *et al.* (2000), extrudates made of 100% oat flour had a significantly lower expansion than the extrudates when corn flour was added with oat flour. When 100% WF was used in our experiments, extrudates were less expanded and harder compared to the EF extrudates. Liu *et al.* (2000) reported that addition of 15% of corn flour into oat flour significantly increased the expansion of the extrudates. In another study, addition of oat bran (up to 37% of solids) increased hardness of extrudates, while addition of corn starch (up to 25% of solids) into the mixture of oat bran and defatted soy flour decreased hardness (Lobato *et al.*, 2011). In this study, addition of corn starch (30% of solids) to endosperm flour increased the expansion and decreased hardness significantly compared to the extrudates without corn starch.

Lue *et al.* (1991) found that extruded cereal product with high dietary fibre content had low expansion with hard texture. Extrudate with high percentage EF and OBC in this study exhibited similar characteristics due to the high content of fibre. Stanley (1986) stated that the texture of extrudates was greatly influenced by the composition of raw materials. He observed that when higher amount of fibre was added to the extruded mass, hardness and density of the extrudates was increased. Similar results related to the increased hardness with high fibre content have also been shown by other researchers (Hsieh *et al.*, 1991; Jin *et al.*, 1995; Mendonca *et al.*, 2000; Yanniotis, *et al.*, 2007). Fibres rupture air cell walls of the extrudates, thus preventing the full expansion of air bubbles. This might be the reason for decreased expansion and increased hardness with increased amount of fibrous raw material, such as whole grain oat flour or oat bran (Lue *et al.*, 1990). Mendonca *et al.* (2000) reported that the expansion of the extrudates made of a mixture of corn starch and corn bran decreased with increasing corn bran content.

Rzedzicki (1998) recommended that the maximal amount of added oat bran would be 20%, when using 50% oat flour with 30% corn starch. Unstable run of equipment was observed in their study with higher addition of oat fractions, due to their high fat content. In this

study, the trial of defatted EF blended with 20% OBC and 30% CS was successful and no unstable run of the extruder was observed. The most probable reason is that oat fractions were defatted in this study. Use of 100% EF (defatted) extrudates were expanded and less hard although Rzedzicki (1998) reported that production of good quality extrudates was not possible with only oat-derived fractions (non-defatted), as the final products were hard and poorly expanded.

3.5.1.2. Effect of corn starch

Addition of corn starch (30% of solids) increased expansion and decreased hardness in this study (Table 6). The highest expansion and the lowest hardness of the extrudates obtained with the addition of 30% waxy corn starch. This was consistent with the study of Holguin-Acuna *et al.* (2008). According to their sensory analyses, oat based extrudates containing 30% corn starch had better physical properties.

Most studies claimed that gelatinized starch plays an important role in expansion by providing the gas holding capacity for the extruded mass. On the other hand, ingredients such as protein and fibre, have been claimed to reduce the expansion (Guy, 1994; Moraru and Kokini, 2003). For a high expansion of the extrudates, minimal content of 60–70% starch is needed (Conway, 1971). The percentage of starch (61–69%) in the present study met this range. However, high percentage of protein (12.8–17.5%) and fibre (2.5–10.7%) in combination with higher percentage of β -glucan (1.3–6.3%) led to a lower expansion.

In this study, more expanded and less hard extrudates were obtained with the addition of waxy corn starch (97% amylopectin) than normal pregelatinised corn starch (75% amylopectin) into a mixture of defatted EF and OBC. Similar observations were reported by several studies when amylopectin rich corn starch was used in the extrusion mass (Kim and Maga, 1987; Chinnaswamy and Hanna, 1988; Chinnaswamy and Hanna, 1990; Mertinez-Serna and Villota, 1992; Matthey and Hanna, 1997; Onwulata *et al.*, 1998; Allen *et al.*, 2007). Moraru and Kokini (2003) stated that amylopectin-rich starches caused higher expansion of the extrudates compared to amylose rich starch because amylose chains align themselves during the cooling after gelatinization. Therefore, it becomes difficult to pull them apart during the expansion. Moreover, the linear structure of amylose allowed increasing the viscosity of extruded mass. Li *et al.* (2004) found similar results when measuring the rheological properties of high amylose and amylopectin starches. They concluded that highly branched polymers (e.g., amylopectin) are favorable for the

expansion. Branched amylopectin is more susceptible to shear forces. Thus, the breakdown of amylopectin-rich starch occurs more easily than for the linear amylose-rich starch.

3.5.1.3. Effect of protein

The addition of defatted oat protein concentrate (10% of solids) to the defatted endosperm oat flour (containing 16.7% protein), with or without the addition of pregelatinised corn starch and oat bran concentrate, gave less expanded and harder extrudates than in the trials without addition of oat protein concentrate. The addition of protein has also shown to decrease the expansion in other studies (Hsieh *et al.*, 1990, 1991; Jin *et al.*, 1994). Moreover, expansion has shown to be dependent on the extrusion process conditions and the raw material composition of the extruded mass. Addition of protein in the extruded mass did not only decrease the expansion but it also increased the hardness and density of the extrudates (Chinnaswamy and Hanna, 1988, 1990; Matthey and Hanna, 1997; Allen *et al.*, 2007). The reduced expansion of the extrudates was observed with increasing the percentage of starch rich in amylose and protein as these two molecules were tend to align themselves linearly (Kim and Maga, 1987; Colonna *et al.*, 1989; Matthey and Hanna, 1997). Matthey and Hanna (1997) proposed that this alignment of the molecules would favour the formation of amylose–protein complex. Therefore, these starch–protein interactions might inhibit the degradation of the starch in the extruder. Moreover, proteins may also affect the water distribution properties and contribute to the formation of extensive network during the extrusion process (Madeka and Kokini, 1992; Li and Lee, 1996).

Faubion and Hoseney (1982) reported that the effect of proteins on the expansion depends widely on their type and amount. Most studies reported that an addition of a small amount of protein may increase the expansion. However, when certain content exceeded, proteins tend to decrease the expansion of the extrudates depending on protein type e.g., for soy protein maximum addition content is 8%. In our experiments, addition of 10% protein gave slightly less expanded and harder extrudates compared to the trial with 100% EF. Lobato *et al.* (2011) stated that the addition of soy protein into a mixture up to 20–30% can decrease the expansion to about half compared to the extrudates without added protein.

3.5.1.4. Effect of fibre

Extruded mass with high fibre content (about 7%) after the addition of various oat bran concentrates caused less expanded and harder extrudates. By the addition of corn starch, the expansion was able to be increased even in the trials with the highest fibre content (about 10.5%). Lue *et al.* (1991) also found that extruded cereal product with high fibre content had low expansion and hard texture. Mendonca *et al.* (2000) stated that extrudates made of corn flour resulted in less expanded and harder extrudates when the corn bran content was increased. Similar results were found when corn flour was extruded with various types of fibres such as flaxseed, stabilized oat, pure cellulose, soybean and sugar beet fiber (Chinnaswamy and Hanna, 1991; Hsieh *et al.*, 1991; Lue *et al.*, 1991; Hu *et al.*, 1993; Jin *et al.*, 1994, 1995; Ahmed, 1999; Onwulata *et al.*, 2000).

Some studies have concluded that not only lipid but also dietary fibre had major role in the expansion phenomenon (Su and Kong, 2007). In this study, the use of defatted oat fraction caused increased expansion even though high amount of fibre was present. Moraru and Kokini (2003) suggested that addition of fibres above a certain amount may disrupt the continuous structure of the extruded mass, impeding its elastic deformation during expansion. Fibres can also bind some water present in the matrix, thus reducing its availability for expansion. Jin *et al.* (1995) found that increased fibre content resulted in lower expansion with smaller air cells and thicker cell walls.

During expansion, fibres tend to reduce the extensibility of cell walls. Insoluble fibre reduces the extensibility more than soluble fibre, such as β -glucan. Therefore, a greater percentage of insoluble dietary fibre in extruded mass may cause lower expansion of the extrudates. In this study, a high expansion was achieved even though up to 7.4% β -glucan (dry weight) was present. However, higher percentage of starch up to 67% was most likely responsible for the greater expansion. The reason for the increased expansion was a stretchable gas holding matrix in the extruded mass, provided by the high amount of starch (Chen *et al.*, 2002).

3.5.1.5. Effect of particle size and enzyme hydrolysis of oat bran

In the present study, the ultra-fine bran concentrate (UBC) did not show any difference in expansion compared to the untreated oat bran concentrate (OBC). The results were not consistent with the previous studies. Several studies have reported that more expanded and porous extrudates can be obtained by decreasing the particle size of the mass material (Moore *et al.*, 1990; Lue *et al.*, 1991). Generally, there was a negative relationship between the expansion of extrudates and the particle size of the raw materials. Halek and Chang (1992) observed a significant increase in the bulk density and hardness, when the largest particle sized materials were extruded at screw speed 300 rpm and high water content of the mass of 22% compared to the small particle size. Similar results found by Garber *et al.* 1997, when they extruded corn flour of different particle size (50–1622 μm). Significant increase in the bulk density and hardness was found at the water content of the mass of 22% with largest particle size (1622 μm) at screw speed 200 and 300 rpm.

It is notable that addition of ultra-fine bran (UBC) made the extrudates less crispy than the bran concentrate (OBC). One of the possible reasons for the less crispiness of UBC containing extrudates is caused by the lowering of the particle size. When the particle size is smaller it might act as filler within the matrix and gives a rigid cell structure. On the other hand, coarse particle interferes with the matrix and finally gives a weaker structure which is easy to break.

In this study only a small amount (10% of solids) of UBC was used, which was not enough to show the effect of lowering the particle size on the expansion and hardness. However, same amount of EBC was able to reduce the hardness even though the expansion was similar compared to the OBC.

3.5.2. Effect of process variables on the physical properties of extrudates

3.5.2.1. Effect of screw speed

In the present study, maximum expansion was obtained with the highest screw speed and with the lowest water content of the mass. Screw speed had significant effect on the expansion of oat-based extrudates as the expansion of both 100% EF and WF containing extrudates was affected by the screw speed, which is consistent with the finding of Ozer *et al.* (2004). They reported that screw speed and water content of the mass had a significant effect on the expansion, while the effect of feed rate was not found on expansion properties. Screw speed increased the shear forces inside the extruder barrel thus giving uniform and more developed mass with better expansion when exit the die.

Liu *et al.* (2000) reported that screw speed had no significant effect on the expansion when 100% oat flour was used. This might be caused by high lipid content of oat flour, which provided a lubrication effect into the extruder barrel. In this study, however, extrusions with defatted oat flours showed opposite results, where screw speed had the significant effect on expansion. Colonna *et al.* (1989) reported that when lipids were present, the modification of starch was less extensive. Therefore, removal of lipids may cause increased expansion with increased screw speed. On the other hand, increased screw speed might also decrease the hardness by increasing the product temperature, which usually causes higher expansion of the extrudates (Liu *et al.*, 2000). In this study, hardness was greatly affected by the expansion of the extrudates: highly expanded extrudates were less hard in all trials. It is notable that in WF trial, screw speed affected expansion ($p < 0.05$) interacting with water content of the mass, which tend to reduced expansion.

In present study, when screw speed was increased, a decrease in the die pressure was reported in trials with 100% EF and 100% WF. The inverse relationship between the die pressure and screw speed was also reported by Bhattacharya and Hanna (1987), Hsieh *et al.* (1991, 1993) and Liang *et al.* (1994). Increased screw speed caused a decrease in the filling of the extruder barrel, thus less extruded mass was accumulated at the die, leading to a decreased die pressure (Hu *et al.*, 1993). High screw speed requires more energy, which raises the temperature of the product and hence lowers the viscosity of the mass. This usually leads to decreased pressure at the die (Harper, 1981; Janssen, 1989; Hu *et al.*, 1993). Willett *et al.* (1997) investigated that during the extrusion of corn starch, torque and pressure values were excessive at high screw speed when water content of the mass was

lower than 18%. However, in this study use of 30% corn starch did not cause excessively high pressure or torque even decreased torque was found with increased screw speed.

3.5.2.2. Effect of water content of the mass

In this study, water content of the mass affected all the response variables in WF trial and all except hardness and torque in EF trial. Water content of the mass caused reduced expansion of EF and WF extrudates. Water content of the mass was also affecting the expansion of WF containing extrudates interacting with screw speed ($p < 0.05$). Hardness of WF extrudates decreased with increasing water content but no significant effect ($p > 0.05$) was found on the hardness of EF extrudates. Several studies have shown that increasing water content of the mass resulted lower degree of starch gelatinization during the extrusion process and the expansion was usually decreased (Kokini *et al.*, 1992; Ilo *et al.*, 1996; Parsons *et al.*, 1996; Liu *et al.*, 2000; Rzedzicki *et al.*, 2000; Onwulata *et al.*, 2001; Ding *et al.*, 2006;). Increasing water content of the mass might also decrease the temperature of the mass as water reduces the friction between the mass and the screws. This has a negative effect on the starch gelatinization and leads to a lower expansion of the product (Liu *et al.*, 2000). According to Ilo *et al.* (1996), increased water content might also reduce the viscosity of the mass and leads to a decreased expansion. On the other hand, decreased water content of the mass increased the torque during an extrusion of oat and corn starch-mixture (Singh *et al.*, 1997). Decreased water content of the mass can cause an increase in the viscosity, which usually leads to an increase torque (Garber *et al.*, 1997) and thus increased expansion.

Hardness of the extrudates increased with increasing the water content of the mass. The increase of hardness of the extrudates is usually due to reduced expansion (Liu *et al.*, 2000, Rzedzicki *et al.*, 2000). However, in this study, increasing water content of the mass ($p < 0.01$) decreased hardness of the extrudates containing WF.

3.5.2.3. Effect of feed rate

In the present study feed rate did not have significant effect on the expansion and hardness. Only water content of the extrudates was affected by the feed rate in WF trial. Increased feed rate increased the water content of the extrudates. On the other hand, the only effect with EF was a small increase in the pressure at the die. In some experiments it was difficult to maintain the feed rate constant as the particle size of the flour was very small and stacked in the feeder.

Many studies reported that feed rate did not have significant effect on its own but may affect hardness of the extrudates interacting with screw speed. Ozer *et al.* (2004) showed that feed rate did not affect the hardness without interacting with screw speed. In this study, no interaction between feed rate and screw speed was found.

3.5.3. Correlations

In general, there is an inverse relationship observed between the expansion and hardness. Decreased expansion always gives increased hardness ($p < 0.05$). Hutchinson *et al.* (1987) and Gogoi *et al.* (2000) also reported similar relationship between expansion and hardness. Moreover, extrudates were dense and tough when expansion was decreased (Kim and Maga, 1987; Lue *et al.*, 1991; Mertinez-Serna and Villota, 1992; Matthey and Hanna, 1997; Onwulata *et al.*, 1998). Gibson and Ashby (1997) gave an explanation for the inverse relationship between expansion and hardness: expanded product has large cell and due to stretching, cell wall becomes thinner and the breakdown of the cell walls become easier during hardness measurement. In this study, water content of extrudates negatively correlated with the expansion of extrudates ($p < 0.01$). However, in this study, no correlation was found between hardness and water content of extrudates.

4. CONCLUSIONS

This study showed that it was possible to use defatted oat fractions in extruded snacks. Due to the high fibre content of oat, it was quite difficult to obtain highly expanded and less hard extrudates. Low amount of amylase-rich starch was also responsible for the poor physical properties of oat-containing extrudates. However, addition of corn starch increased the expansion and decreased hardness.

Extrusion trials with 100% oats have shown to be unsuccessful in many studies due to the high lipid content of oats. When using defatted oat endosperm flour, expanded and less hard extrudates, compared to the whole grain flour, were obtained. Although 100% endosperm flour did not provide extrudates with desired physical properties, mixing it with corn starch (30% of solids) gave less hard and more expanded product. Addition of oat bran concentrate decreased the expansion and increased the hardness of the extrudates. However, addition of oat bran up to 20% of solids in the presence of waxy corn starch (30% of solids) gave the most expanded and less hard extrudates. Addition of 10% oat protein concentrate had an adverse effect. Decreasing the particle size of bran concentrate (down to 32 μm) did not cause any significant change in the physical properties of the extrudates compared to the larger particle sized oat bran concentrate (213 μm). Use of an enzymatically hydrolysed bran concentrate did neither increase the expansion, but the hardness of the extrudates was slightly decreased. Using bigger amounts of ultra-fine milled and enzyme-hydrolysed bran concentrate (e.g., 20–30% of solids) might give more clear effect compared to untreated oat bran concentrate. In this study addition was only 10% of the solids, so making the conclusion of the reduced particle size or molecular weight of β -glucan was rather difficult.

The physical properties of extrudates were not only dependent on the composition of the raw material in the mass but also on several process variables such as screw speed, water content of the mass and feed rate. High screw speed and low water content of the mass gave expanded and less hard extrudates. The effect of feed rate was not predominant on the physical properties of extrudates. In the future, water content of the mass lower than 16% water content of the mass could be tested. There might be an effect of the barrel temperature on the physical properties, which was not considered in this study. Therefore, in the future, the effect of temperature (130, 150, 170 $^{\circ}\text{C}$) could be tested rather than using a constant temperature (130 $^{\circ}\text{C}$, at section 6 and die).

REFERENCES

- [AACC] American Association of Cereal Chemists. 1989. AACC Method 32-23.01. Definition of oat bran. Available at: <http://www.aaccnet.org/news/pdfs/OatBran.pdf>. Accessed 11.02.11.
- [AACC] American Association of Cereal Chemists. 1999. AACC Method 32-23.01. β -glucan content of Barley and Oats—Rapid Enzymatic Procedure. In: Approved methods of the American Association of Cereal Chemists. p 1–5. St. Paul, Minnesota: AACC.
- [AACC] American Association of Cereal Chemists. 2001. In: AACC international 46(3). Available at: <http://www.aaccnet.org/DietaryFibre/pdfs/dietfibre.pdf>. Accessed 13.02.11.
- [EFSA] European Food Safety Authority. 2010. Scientific Opinion on the substantiation of a health claim related to oat beta-glucan and lowering blood cholesterol and reduced risk of (coronary) heart disease pursuant to Article 14 of Regulation EC No 1924/2006. EFSA Journal 8(12):1885. Available at: <http://www.promoat.com/pdf/efsa-ruling.pdf>. Accessed 06.05.11.
- [EU] European Union. 2011. Commission regulation (EU) No 1160/2011 on the authorisation and refusal of authorisation of certain health claims made on foods and referring to the reduction of disease risk. Official Journal of the European Union L 296/26–28. Available at: <http://eur-lex.europa.eu/LexUriServ/LexUriServ.do?uri=OJ:L:2011:296:0026:0028:EN:PDF>. Accessed 02.12.11.
- [FAO] Food and Agriculture Organization. 1987. The nutrition and feeding of farmed fish and shrimp; a training manual 2: Nutrient sources and composition. In: corporate document repository. p 137. Available at: <http://www.fao.org/docrep/field/003/AB468E/AB468E00.htm>. Accessed 13.02.11.
- [FDA] Food and Drug Administration of USA. 1997. 21 CFR Part 101. Food labeling, health claims: soluble dietary fibre from certain foods and coronary heart disease. Federal Register 62 (15), 3584–3601. Available at: <http://www.fda.gov/Food/LabelingNutrition/LabelClaims/HealthClaimsMeetingSignificantScientificAgreementSSA/ucm074719.htm>. Accessed 06.05.11.
- Ahmed ZS. 1999. Physico-chemical, structural and sensory quality of corn-based flax-snack. *Nahrung* 43:253–258.
- Ahokas H, Heikkilä E, Alho M. 2005. Variation in the ratio of oat (*Avena*) protein fractions of interest in celiac grain diets. *Genetic Resource and Crop Evolution* 52: 813–819.
- Ainsworth P, Ibanoglu S, Plunkett A, Ibanoglu E, Stojceska V. 2007. Effect of brewer's spent grain addition and speed on the selected physical and nutritional properties of an extruded snack. *Journal of Food Engineering* 81:702–709.
- Allen KE, Carpenter CE, Walsh MK. 2007. Influence of protein level and starch type on an extrusion-expanded whey product. *International Journal of Food Science and Technology* 42:953–960.
- Åman P, Rimsten L, Anderson R. (2004). Molecular weight distribution of β -glucan in oat-based foods. *Cereal Chemistry* 81(3):356–360.
- Autio K, Eliasson AC. 2009. Oat starch. In: *Starch chemistry and Technology*. Edited by BeMiller J. and Whistler R. 3rd edition. Park Avenue South, NY, USA: Elsevier Inc. p 589–598.
- Autio K. 2006. Functional aspects of cereal cell-wall polysaccharides. In: *Carbohydrate in Food*. Edited by Eliasson AC. 2nd edition. Boca Raton, FL, USA: CRC press. p 167–207.

- Battachariya S, prakash M. (1994). Extrusion of blends of rice and chick pea flours: a response surface analysis. *Journal of Food Engineering* 21:315–330.
- Bhattacharya M, Hanna MA. 1987. Influence of process and product variables on extrusion energy and pressure requirements. *Journal of Food Engineering* 6:153–163.
- Brown L, Rosner B, Willett WW, Sacks FM. 1999. Cholesterol-lowering effects of dietary fibre: a meta-analysis. *American Journal of Clinical Nutrition* 69:30–42.
- Butt MS, Tahir-Nadeem M, Khan MKI, Shabir R, Butt MS 2008. Oat: unique among the cereals. *European Journal of Nutrition* 47:68–79.
- Cha JY, Chung DS, Seib PA, Flores RA, Hanna MA. 2001. Physical properties of starch-based foams as affected by extrusion temperature and moisture content. *Industrial Crops and Products* 14:23–30.
- Chang PR, Susulki FW. 1985. Functional properties of dry milled fractions from wild oats. *Journal of Food Science* 50:1143–1147.
- Charalampopoulos D, Wang R, Pandiella SS, Webb C. 2002. Application of cereals and cereal components in functional foods: a review. *International Journal of Food Microbiology* 79:131–141.
- Chen KHJ, Dogan E, Rizvi SSH. 2002. Supercritical fluid extrusion of masa-based snack chips. *Cereal Foods World* 47:44–51.
- Chinnaswamy R, Hanna MA. 1988. Relationship between amylose content and extrusion-expansion properties of corn starches. *Cereal Chemistry* 65:138–143.
- Chinnaswamy R, Hanna MA. 1990. Relationship between viscosity and expansion properties of variously extrusion-cooked corn grain components. *Food Hydrocolloids* 3:423–434.
- Chinnaswamy R, Hanna MA. 1991. Physicochemical and macromolecular properties of starch–cellulose fibre extrudates. *Food Structure* 10(3):229–239.
- Colonna P, Tayeb J, Mercier C. 1989. Extrusion cooking of starch and starchy products. In: *Extrusion cooking*. Edited by Mercier C, Linko P, Harper JM. St. Paul, MN:AACC International. p 247–319.
- Conway HF. 1971. Extrusion cooking of cereals and soybeans. Part I. *Food Product Development* 5:29.
- Cremer DR, Kaletunc G. 2003. Fourier transform infrared microspectroscopic study of the chemical microstructure of corn and oat flour-based extrudates. *Carbohydrate Polymers* 52:53–65.
- Delcour JA, Hoseney RC. 2010. *Principles of cereal science and technology*. 3rd edition. St. Paul, MN: AACC International. p 72–76.
- Desrumaux A, Bouvier JM, Burri J. 1999. Effect of free fatty acids addition on corn grits extrusion cooking. *Cereal Chemistry* 76:699–704.
- Ding QB, Ainsworth P, Plunkett A, Tucker G, Marson H. 2006. The effect of extrusion conditions on the functional and physical properties of wheat-based expanded snacks. *Journal of Food Engineering* 73:142–148.
- Doehlert DC, Moore WR. 1997. Composition of oat bran and flour prepared by three different mechanisms of dry milling. *Cereal Chemistry* 74(4):403–406.

- Doehlert DC, Moreau RA, Welti R, Roth MR, McMullen MC. 2010. Polar lipids from oat kernels. *Cereal Chemistry* 87(5):467–474.
- Drzikova B, Dongowski G, Gebhardt E, Habel A. 2004. The composition of dietary fibre-rich extrudates from oat affects bile acid binding and fermentation in vitro. *Food Chemistry* 90:181–192.
- Duss R, Nyberg L. 2004. Oat soluble fibres (β -glucans) as a source for healthy snack and breakfast foods. *Cereal Foods World* 49(6): 320–325.
- Fahrenholz C. 1998. Cereal grains and by-products: What's in them and how are they processed? In: *Advances in Equine Nutrition*. Edited by Pagan JD. Nottingham University Press, Nottingham, U.K. p 57–70.
- Faubion JM, Hosoney RC. 1982. High-temperature short-time extrusion cooking of wheat starch and flour. II Effect of protein and lipid on extrudate properties. *Cereal Chemistry* 59(6):533–537.
- Fornal L, Majewska K, Kondrusik R, Wojcik E. 1995. Application of oat grain in extrusion cooking. *Acta Academiae Agriculturae ac Technicae Olstenensis. Technologia Alimentorum* 28:109–118.
- Fredriksson H, Silverio J, Andersson R, Eliasson AC, Aman P. 1997. The influence of amylose and amylopectin characteristics on gelatinization and retrogradation properties of different starches. *Carbohydrate Polymer* 35:119–134.
- Garber BW, Hsieh F, Huff HE. 1997. Influence of particle size on the twin-screw extrusion of corn meal. *Cereal Chemistry* 74(5):656–661.
- Gates FK, Antilla H, Sontag-Strohm T, Salovaara H. 2005. Rheological properties of cooked oat bran. In: *Nordic Rheology Conference*. Nordic Rheology Society 13:255–257.
- Gibson LJ, Ashby MF. 1997. The mechanics of foams: Basic results. In: *Cellular Solids*. Edited by Gibson JL, Ashby MF. Cambridge University Press: Cambridge, UK. p 175–234.
- Gogoi BK, Alavi SH, Khan M, Bowman BJ, Rizvi SSH. 2000. Mechanical properties of protein-stabilized starch-based supercritical fluid extrudates. *International Journal of Food Properties* 3:37–58.
- Gordon WA, James R. 1986. Process for preparing a highly expanded oat cereal product. US patent 4,260,981.
- Grigelmo-Miguel N, Carreras-Boladeras E, Martin-Belloso O. 2001. Influence of the addition of peach dietary fibre in composition, physical properties and acceptability of reduced-fat muffins. *Food Science and Technology International* 7:425–431.
- Guy RCE. (1994). Raw material for extrusion cooking processes. In: *The Technology of Extrusion Cooking*. Edited by Frame ND. Glasgow, UK: Chapman and Hall. p 52–72.
- Halek GW, Chang KLB. 1992. Effect of extrusion operation variables on functionality of extrudates. In: *Food Extrusion Science and Technology*. Edited by Kokini JL, Ho C, Karwe MV. Marcel Dekker: New York. p 677–692.
- Harper JM. 1981. *Extrusion of Foods, Vol. I*. CRC Press: Boca Raton, FL.
- Heneen, WK, Banas, A, Leonova, S, Carlsson, AS, Marttila, S, Debski, H, Stymne, S. 2009. The distribution of oil in the oat grain. *Plant Signaling & Behavior* 4:55–56.

- Holguín-Acuña AL, Carvajal-Millán E, Santana-Rodríguez V, Rascón-chu A, Márquez-Escalante JA, León-Renova NEP, Gastelum-Franco G. 2008. Maize bran/oat flour extruded breakfast cereal: A novel source of complex polysaccharides and an antioxidant. *Food Chemistry* 111:654–657.
- Hsieh F, Huff HE, Lue S, Stringer L. 1991. Twin-screw extrusion of sugar beet and corn meal. *LWT- Food Science and Technology* 24:495–500.
- Hsieh F, Peng IC, and Huff HE. 1990. Effects of salt, sugar and screw speed on processing and product variables of corn meal extruded with a twin-screw extruder. *Journal of Food Science* 55:224–227.
- Hu L, Hsieh F, Huff HE. 1993. Corn meal extrusion with emulsifier and soybean fibre. *LWT- Food Science and Technology* 26(6):544–551.
- Hutchinson RJ, Siodlak GDE, Smith AC. 1987. Influence of process variables on mechanical properties of extruded maize. *Journal of Material Science* 22:3956–3962.
- Ilo S, Tomschik U, Berghofer E, Mundigler N. 1996. The effect of extrusion operating conditions on the apparent viscosity and properties of extrudates in twin-screw extrusion cooking of maize grits. *LWT- Food Science and Technology* 29:593–598.
- Inglett GE, Grisamore SB. 1991. Maltodextrin fat substitute lowers cholesterol. *Food Technology* 45(6):104–108.
- Inglett GE. Application Date: 28.11.1995. Dietary fiber gels for preparing calorie reduced foods. U.S. Patent 9719603.
- Inglett GE. Application Date: 30.06.1989. Water-soluble dietary fiber compositions from oats. U.S. Patent 373978.
- Izydorczyk MS, Biliaderis CB. 2007. Arabinoxylans: technologically and nutritionally functional plant polysaccharides. In: *Functional Food Carbohydrate*. Boca Raton, FL, USA: CRC press. p 249–282.
- Jane J-L. 2003. Starch: structure and properties. In: *Chemical and Functional Properties of Food Saccharides*. Edited by Tomasik P. CRC press LLC.
- Janssen LPBM. 1989. Engineering aspects of food extrusion. In: *Extrusion Cooking*. Edited by Mercier P, Linko J, Harper JM. American Association of Cereal Chemistry: St. Paul, Minnesota: AACC. p 17–39.
- Jin Z, Hsieh F, Huff HE. 1994. Extrusion-cooking of corn meal with soy fibre, salt and sugar. *Cereal Chemistry* 71:227–234.
- Jin Z, Hsieh F, Huff HE. 1995. Effects of soy fibre, salt, sugar and screw speed on physical-properties and microstructure of corn meal extrudate. *Journal of Cereal Science* 22(2):185–194.
- Kaukovirta-Norja A, Myllumäki O, Pihlava JM, Hietaniemi V, Lehtinen P, Poutanen K. 2008. Development of functional oat ingredients for health food market. MTT Agrifood Research Finland. Available at: http://www.oatsandhealth.org/index.php?option=com_docman&task=cat_view&gid=11&Itemid=3. Accessed 11.02.11.
- Keenan JM, Goulson M, Shamliyan1 T, Knutson N, Kolberg L, Curry L. 2007. The effects of concentrated barley β -glucan on blood lipids in a population of hypercholesterolaemic men and women. *British Journal of Nutrition* 97:1162–1168.

- Kim CH. and Maga JA. 1987. Properties of extruded whey protein concentrate and cereal flour blends. *LWT- Food Science and Technology* 20:311–318.
- Kivelä R. 2011. Non-enzymatic degradation of (1→3) (1→4)-β-D-glucan in aqueous processing of oats. [PhD thesis]. EKT Series 1518. Helsinki: University of Helsinki, Department of Food and Environmental Sciences. 77 p. Available at: <http://urn.fi/URN:ISBN:978-952-10-7097-6>
- Koester E. 2008. Properties of extruded white corn flour-high amylose corn starch puffs. [MSc thesis]. Missouri, Columbia: University of Missouri, Department of Biological Engineering. Available at: <http://hdl.handle.net/10355/5766>
- Kokini JL, Chang CN, and Lai LS. 1992. The role of rheological properties on extrudate expansion. In: *Food Extrusion Science and Technology*. Edited by Kokini JC, Ho CT, Karwe MV. Marcel Dekker: New York. p 631–652.
- Kumagai H, Lee BH, Yano T. 1987. Flour treatment to improve the quality of extrusion-cooked rice flour products. *Journal of Agricultural and Biological Chemistry* 51:2067–2071.
- Kvist S. Carlsson T. Application Date: 26.02.2001. Process for the fractionation of cereal brans. WO Patent 2002/067698.
- Kvist S. Lawther JM. Application Date: 17.06.2004. Concentration of beta-glucans. WO Patent 2005/122785.
- Lasztity R. 1998. Oat grain- a wonderful reservoir of natural nutrients and biologically active substances. *Food Reviews International* 14(1):99–119.
- Lehtinen P. 2009. Rye and oats- innovative processing and ingredients. Grainity project satellite symposium: Nordic experience and approaches on using grains for health. Available at: http://www.oatsandhealth.org/index.php?option=com_docman&task=cat_view&gid=11&Itemid=3. Accessed 11.02.11.
- Li M, Lee TC. 1996. Effect of extrusion temperature on solubility and molecular weight distribution of wheat flour proteins. *Journal of Agricultural and Food Chemistry* 44:763–768.
- Liang M, Hsieh F, Huff HE, Hu L. 1994. Barrel-valve assembly affects twin-screw extrusion cooking of corn meal. *Journal of Food Science* 59:890–894.
- Lim WJ, Liang YT, Seib PA, Rao CS. 1992. Isolation of Oat Starch from Oat Flour. *Cereal Chemistry* 69:233–236.
- Lin GG, Shih HH, Chai PC, Hsu SJ. 2002. Influence of side-chain structures on the viscoelasticity and elongation viscosity of polyethylene melts. *Polymer Engineering and Science* 42:2213–2221.
- Lin S, Hsieh F, Huff HE. 1997. Effects of lipids and processing conditions on degree of starch gelatinization of extruded dry pet food. *LWT- Food Science and Technology* 30:754–761.
- Liu Y, Hsieh H, Heymann H, Huff HE. 2000. Effect of process condition on the physical and sensory properties of extruded oat-corn puff. *Journal of Food Science* 65(7):1253–1259.
- Lobato LP, Anibal D, Lazaretti MM, Grossmann MVE. 2011. Extruded puffed functional ingredients with oat bran and soy flour. *LWT- Food Science and Technology* 44:933–939.
- Lue S, Hsieh F, Huff HE. 1991. Extrusion cooking of corn meal and sugar beet fibre: effects on expansion properties, starch gelatinization, and dietary fibre content. *Cereal Chemistry* 68:227–234.

- Lue S, Hsieh F, Peng IC, Huff HE. 1990. Expansion of corn extrudates containing dietary fibre: a microstructure study. *LWT- Food Science and Technology* 23:165–173.
- Lue S, Hsieh H, Huff HE. 1994. Modeling of twin-screw extrusion-cooking of cornmeal and sugar-beet fibre mixtures. *Journal of Food Engineering* 21(3):263–289.
- Ma CY, Harwalkar VR. 2006. Studies of thermal denaturation of oat globulin by differential scanning calorimetry. *Journal of Food Science* 53(2):531–534.
- Ma CY, Rout MK, Chan WM, Phillips DL. 2000. Raman spectroscopy study of oat globulin conformation. *Journal of Agricultural and Food Chemistry* 48(5):1542–154.
- Madeka H, Kokini JL. 1992. Effect of addition of zein and gliadin on the rheological properties of amylopectin starch with low-to-intermediate moisture. *Cereal Chemistry* 69:489–494.
- Mälkki Y, Myllymäki O, Teinila K, Koponen S. 2003. Method for preparing an oat product and a foodstuff enriched in the content of beta-glucan. Patent application publication. Pub No: US 2003/0087019 A1.
- Mälkki Y, Törrönen R, Pelkonen K, Myllymäki O, Häninnen O, Syrjänen K. 1993. Effects of oat-bran concentrate on rat serum lipids and liver fat infiltration. *British Journal of Nutrition* 70:167–116.
- Mälkki Y, Vartanen E. 2001. Gastrointestinal effects of oat bran and oat gum: a review. *LWT- Food Science and Technology* 34:337–347.
- Mälkki Y. 2001. Oat Fibre: Production, composition, physicochemical properties, physiological effects, safety and food applications. In: *Handbook of dietary fibre*. Marcel Dekker: New York. p 497–517.
- Martinez-Serna MD, Villota R. 1992. Reactivity, functionality, and extrusion performance of native and chemically modified whey proteins. In: *Food Extrusion Science and Technology*. Edited by Kokini JL, Ho CT, Karwe MV. Marcel Dekker: New York. p 387–414.
- Matthey FP, Hanna MA. 1997. Physical and functional properties of twin-screw extruded whey protein concentrate-corn starch blends. *LWT- Food Science and Technology* 30:359–366.
- Mendonca S, Grossmann MVE, Verhe R. 2000. Corn bran as a fibre source in expanded snacks. *LWT- Food Science and Technology* 33(1):2–8.
- Mirmoghtadie L, Kadivar M, Shahedi M. 2009. Effect of succinylation and deamidation on functional properties of oat protein isolate. *Food Chemistry* 114:127–131.
- Mohamed A, Biresaw G, Xu J, Hojilla-Evangelista MP, Rayas-Duarte P. 2009. Oat protein Isolate: Thermal, rheological, surface and functional properties. *Food Research International* 42:107–114.
- Moore D, Samei A, Vanhecke E, Bouvier, JM. 1990. Effect of ingredients on physical/structural properties of extrudates. *Journal of Food Science* 55:1383–1387.
- Moraru CI, Kokini JL. 2003. Nucleation and expansion during extrusion and microwave heating of cereal foods. *Comprehensive Reviews in Food Science and Food Safety* 2:147–165.
- Oat ingredients. 2008. Technology in using oat and oat ingredients. Available at: http://www.oatsandhealth.org/index.php?option=com_docman&task=cat_view&gid=11&Itemid=3. Accessed 11.02.11.
- Onwulata CI, Konstance RP, Strange ED, Smith PW, Holsinger VH. 2000. High-fibre snacks extruded from triticale and wheat formulations. *Cereal Foods World* 45(10):470–473.

- Onwulata CI, Smith PW, Konstance RP, and Holsinger VH. 2001. Incorporation of whey products in extruded corn, potato or rice snacks. *Food Research International* 34:679–687.
- Onwulata CI, Smith PW, Konstance RP, Holsinger VH. 1998. Physical properties of extruded products as affected by cheese whey. *Journal of Food Science* 63:814–818.
- Onwulata CI. 2008. Use of extrusion-texturized whey protein isolate in puffed corn meal. Eastern Regional Research Center, Dairy Processing and Products Unit.
- Ozer EA, Ibanoglu S, Ainsworth P, Yagmur C. 2004. Expansion characteristics of a nutritious extruded snack food using response surface methodology. *European Food Research and Technology* 218:474–479.
- Pai DA, Blake OA, Hamaker BR, Campanella OH. 2009. Importance of extensional rheological properties on fibre-enriched corn extrudates. *Journal of Cereal Science* 50:227–234.
- Parsons MH, Hsieh F, Huff HE. 1996. Extrusion cooking of cornmeal with sodium bicarbonate and sodium aluminum phosphate. *Journal of Food Processing and Preservation* 20:221–234.
- Peterson DM. 2004. Oat- multifunctional grain. In: 7th international oat conference. Helsinki, Finland. *Agri Food Research Report* 51:21–26.
- Pilli TD, Derossi A, Talja RA, Jouppila K, Sevirini C. 2011. Study of starch-lipid complexes in model system and real food product using extrusion-cooking technology. *Innovative Food Science and Emerging Technology* 12:610–616.
- Potter RC. Fisher PA. Application Date: 17.02.1999. Polysaccharide compositions and uses thereof. U.S. Patent 6485945.
- Prinyawiwatkul W, MacWatters KH, Beuchat LR, Philips RD. 1996. Cowpea flour: A potential ingredient in food products. *Critical Reviews in Food Science and Nutrition* 36:413–436.
- Regina A, Kosar-Hashemi B, Ling S, Li Z, Rahman S, Morell M. 2010. Control of starch branching in barley defined through differential RNAi suppression of starch branching enzyme IIa and IIb. *Journal of Experimental Botany* 61:1469–1482.
- Reyna-Villasmil N, Bermudez-Pirela V, Mengual-Moreno E, Arias N, Cano-Ponce C, Leal-Gonzalez E, Souki A, Inglett GE, Israili ZH, Hernandez-Hernandez R, Valasco M, Arraiz N. 2007. Oat-derived β -glucan significantly improves HDLC and diminishes LDLC and non-HDL cholesterol in overweight individuals with mild hypercholesterolemia. *American Journal of Therapeutics* 14:203–212.
- Riahi E, Ramaswamy HS. 2003. Structure and composition of cereal grains and legumes. In: *Handbook of Postharvest Technology*:1–16.
- Riaz MN. 2006. Extruded snacks. In: *Handbook of Food Science, Technology and Engineering*. Edited by Hui YH. CRC Press: Boca Raton, FL.
- Ripsin CM, Keenan JM, Jacobs DR, Elmer PJ, Welch R. R, Horn LV, Turnbull WH, Thye FW, Kestin M, Hegsted M, Davidson DM, Davidson MH, Dugan LD, Demark-Wahnefried W, Deling, S. 1992. Oat products and lipid lowering: a meta analysis. *Journal of American Medical Association* 267:3317–3325.
- Rzedzicki Z, Blaszcak W. 2005. Impact of microstructure in modeling physical properties of cereal extrudates. *International Agrophysics* 19:175–186.
- Rzedzicki Z, Szpryngiel B, Sobota A. 2000. Estimation of some chosen physical properties of extrudates obtained from corn semolina and oat bran mixtures. *International Agrophysics* 14:233–239.

- Rzedzicki Z. 1998. Physical properties of corn-oat bran snacks. *International Agrophysics* 13:381–385.
- Salmenkallio-Martilla M, Heinio RL, Myllymäki O, Lille M, Autio K, Poutanen K. 2004. Relating microstructure, sensory and instrumental texture of processed oat. *Agriculture and Food Science* 13:124–137.
- Santillan-Moreno A, Martinez-Bustos F, Castno-Tostado E, Amaya-Liano S. 2009. Physicochemical Characterization of extruded blends of corn starch- whey protein concentrate- agave tequiana fibre. *Food Bioprocess Technology* 4(9):797–808.
- Shamekh S, Forssell P, Poutanen K. 1994. Solubility pattern and recrystallization behaviour of oat starch. *Starch* 46(4):129–133.
- Shamekh S. 2002. Effects of lipids, heating and enzymatic treatment on starches. A doctoral thesis presented to the Helsinki University of Technology. VTT publications 460. VTT Technical Research Center of Finland. Espoo, Finland.
- Sibakov J, Myllymäki O, Hietaniemi V, Pihlava JM, Kaukovirta-Norja A, Poutanen K, Lehtinen P. 2009. Novel dry fractionation technology to produce oat ingredients with high beta-glucan and protein concentration. Book of Abstracts: presented at 8th workshop for PhD students and young professionals. Viterbo, Italy. Available at: <http://www.cerealsandeuropa.net/var/media/site/8EYCSTW/Book+of+Abstracts+-+8EYCSTW+-+1.pdf>. Accessed 07.05.11.
- Sibakov J, Myllymäki O, Holopainen U, Kaukovirta-Norja A, Hietaniemi V, Pihlava JM, Poutanen K, Lehtinen P. 2011. Lipid removal enhances separation of oat grain cell wall material from starch and protein. *Journal of Cereal Science* 54:104–109.
- Sibakov J, Myllymäki O, Holopainen U, Kaukovirta-Norja A, Hietanimemi V, Pihlava JM, Lehtinen P, Poutanen K. 2012. Minireview: high β -glucan ingredients from oats. In: *AgroFOOD Industry Hi Tech*, article in press.
- Sibakov J. 2011. Concentrated protein ingredients from oats using dry fractionation technology. In *ABS course: Cereal protein functionality and bioactivity*. University of Helsinki. Finland.
- Singh N, Smith AC. 1997. A comparison of wheat starch, whole wheat meal and oat flour in the extrusion cooking process. *Journal of Food Engineering* 34:15–32.
- Singh S, Gamlath S, Wakeling L. 2006. Nutritional aspects of food extrusion: a review. *International Journal of Food Science and Technology* 42:916–929.
- Skoglund M. 2008. Phenolic compounds in oats: effects of steeping, germination and related enzymes. A doctoral thesis presented to Swedish University of Agricultural Sciences. Available at: <http://pub.epsilon.slu.se/1687/1/MSfin0.pdf>. Accessed 05.03.11.
- Sokhey AS, Kollengode AN, Hanna MA. 1994. Screw configuration effects on corn starch expansion during extrusion. *Journal of Food Science* 59:895–898.
- Stanley DW. 1986. Chemical and structural determinants of texture of fabricated foods. *Food Technology* 40:65–68.
- Stenvenson DG, Eller FJ, Jane J, Inglett GE. 2008. Structure and physicochemical properties of defatted and pin-milled oat bran concentrate fractions separated by air classification. *International Journal of Food Science and Technology* 43:995–1003.
- Stevenson DG, Jane JL, Inglett GE. 2007. Structure and physicochemical properties of starches from sieve fractions of oat flour compared with whole and pin-milled flour. *Cereal Chemistry* 84(6):533-539.

- Stojceska V, Ainsworth P, Plunkett A, Ibanoglu S. 2008. The recycling of brewer's processing by-products into ready to eat snacks using extrusion technology. *Journal of Cereal Science* 47:469–479.
- Su C, Kong M. 2007. Effects of soybean oil, cellulose, and SiO₂ addition on the lubrication and product properties of rice extrusion. *Journal of Food Engineering* 78:723–729.
- Sullivan P, O'Flaherty J, Brunton N, Gee VL, Arendt E, Gallagher E. 2010. Chemical composition and microstructure of milled barley. *European Food Research Technology* 230:579–595.
- Tapola N, Sarkkinen E. 2009. Oat β -glucan. *Fibre Ingredients: Food Applications and Health Benefits*. Boca Raton, FL, USA: CRC press. Chapter 13:283–297.
- Thakur S, Saxena DC. 2000. Formulation of extruded snack foods (gum based cereal blend): optimization of ingredients level using response surface methodology. *LWT- Food Science and Technology* 33:354–361.
- Thompson T. 2003. Oats and the gluten free diet. *Journal of the American Diabetic Association* 103(3):376–379.
- Vasanthan T, Temelli F. Application Date: 04.04.2002. Grain fractionation methods and products. WO Patent 02/27011 A2.
- Vicidi KA, Dougherty MP, Briggs J, Camire ME. 2004. Complex phenolic compounds reduce lipid oxidation in extruded oat cereals. *LWT- Food Science and Technology* 37:789–796.
- Wang LZ, White PJ. 1994. Structure and physicochemical properties of starches from oats with different lipid contents. *Cereal Chemistry* 71:443–450.
- Wicklund T, Magnus EM. 1997. Effect of extraction cooking on extractable lipids and fatty acid composition in sifted oat flour. *Cereal Chemistry* 74:326–329.
- Wicklund T. 1995a. Extrusion cooking of a sifted and a whole oat flour. Effect of processing condition on dietary fibre fraction. A doctoral thesis presented to Agriculture University of Norway. Norway.
- Wicklund T. 1995b. Extrusion of oat flours. Influence of processing conditions of functional properties. A doctoral thesis presented to Agriculture University of Norway. Norway.
- Willett JL, Millard MM, Jasberg BK. 1997. Extrusion of waxy maize starch: melt rheology and molecular weight degradation of amylopectin. *Polymer* 38(24):5983–5989.
- Wood PJ. 2007. Cereal β -glucans in diet and health. *Journal of Cereal Science* 46(3):230–238.
- Yağcı, S., Göğüş F, Jouppila K., Talja RA, Hyvönen L, Kristbergsson K. 2012. Extrusion. In: *Food Processing*. Edited by Kristbergsson K, Oates S. ISEKI Food Series Volume 7. Book in press.
- Yanniotis S, Petraki A, Soumpasi E. 2007. Effect of pectin and wheat fibres on quality attributes of extruded cornstarch. *Journal of Food Engineering* 80:594–599.
- Yao N, Jannik JL, Alavi S, and White PJ. 2006. Physical and sensory characteristics of extruded products made from two oat lines with different β -glucan concentrations. *Cereal Chemistry* 83(6):692–699.
- Yao N, White PJ, Alavi S. 2011. Impact of beta glucan and other oat flour components on physico-chemical and sensory properties of extruded oat cereals. *International Journal of Food Science and Technology* 46:651–660.

- Zarzycki P, Rzedzicki Z, Blaszcak W. 2010. Application of oat whole-meal and protein components as modifiers of extrudates microstructure. *International Agrophysics* 24:397–406.
- Zarzycki P, Rzedzicki Z. 2009. Changes in dietary fibre fractional composition of multi-cereal blends caused by extrusion. *International Agrophysics* 23:287–293.
- Zhang M, Bai X, Zhang Z. 2011. Extrusion process improves the functionality of soluble dietary fibre in oat bran. *Journal of Cereal Science*. 54:98–103.
- Zhou M, Robards K, Glennie-Holmes M, Helliwell S. 1999. Oat Lipids. *Journal of the American Oil Chemists' Society* 76(2):159–169.

APPENDICES

Appendix 1. Recipe of different extrusion trials

Raw materials (%) in different extrusion trials	EF (kg)	WF (kg)	OBC (kg)	UBC (kg)	EBC (kg)	PC (kg)	CS (kg)	WS (kg)	Total	NaCl (gm) for salt-water solution (1 liter)		
										16%	18%	20%
EF*(100%)	10.90	–	–	–	–	–	–	–	10.90	94.70	74.40	60.70
WF*(100%)	–	10.90	–	–	–	–	–	–	10.90	94.70	74.40	60.70
EF(90%)+OBC(10%)	2.71	–	0.29	–	–	–	–	–	3.00	88.90		
EF(90%)+UBC(10%)	2.70	–	–	0.30	–	–	–	–	3.00	93.00		
EF(90%)+EBC(10%)	2.70	–	–	–	0.31	–	–	–	3.00	93.00		
EF(90%)+PC(10%)	2.72	–	–	–	–	0.28	–	–	3.00	88.90		
EF(50%)+OBC(20%)+CS(30%)	1.52	–	0.59	–	–	–	0.89	–	3.00	124.0		
EF(50%)+OBC(20%)+WS(30%)	1.49	–	0.58	–	–	–	–	0.93	3.00	124.0		
EF(40%)+OBC(20%)+CS(30%)+PC(10%)	1.37	–	0.67	–	–	0.34	1.01	–	3.39	124.0		

*Extrusion trials with full experimental design, other trials were done with only experiment number 2

EF = Endosperm flour, WF= Whole grain flour, OBC = Bran concentrate, UBC = Ultra-fine bran concentrate, EBC = Enzyme-hydrolysed bran concentrate, PC = Protein concentrate, CS = Pregelatinised corn starch and WS = Waxy corn starch

Appendix 2. Values of response variables in different experiments of 100% endosperm flour (EF) trial

Exp.	Independent process variables			Response variables				
	Water content of mass (%)	Screw speed (rpm)	Feed rate (g/min)	Torque (Nm)	Pressure (bar)	Water content of extrudates (%)	Expansion (%)	Hardness (N/mm)
1	16	240	76	55 ± 2	78 ± 7	11.3 ± 0.3	34 ± 6	190 ± 40
2	16	500	76	43 ± 1	57 ± 9	9.2 ± 0.3	99 ± 8	120 ± 50
3	16	370	68	43 ± 1	61 ± 9	9.5 ± 0.3	72 ± 7	190 ± 20
4	16	370	84	44 ± 2	64 ± 8	9.8 ± 0.1	81 ± 3	150 ± 30
5	18	240	68	53 ± 2	55 ± 6	13.3 ± 0.6	29 ± 5	200 ± 40
6	18	240	84	60 ± 2	73 ± 10	13.4 ± 0.1	33 ± 7	190 ± 50
7	18	500	68	43 ± 2	41 ± 7	10.9 ± 0.6	74 ± 5	160 ± 60
8	18	500	84	43 ± 3	51 ± 8	10.8 ± 0.6	93 ± 5	200 ± 60
9	20	240	76	57 ± 2	53 ± 6	14.7 ± 0.4	26 ± 6	280 ± 80
10	20	500	76	43 ± 1	41 ± 7	12.1 ± 0.7	78 ± 7	160 ± 40
11	20	370	68	45 ± 2	41 ± 8	13.6 ± 0.4	50 ± 6	150 ± 40
12	20	370	84	49 ± 2	46 ± 7	13.6 ± 0.3	52 ± 8	150 ± 40
13	18	370	76	48 ± 4	53 ± 9	10.8 ± 0.2	67 ± 8	170 ± 30
14	18	370	76	50 ± 2	56 ± 8	11.2 ± 0.4	70 ± 4	170 ± 20
15	18	370	76	44 ± 2	55 ± 8	11.5 ± 0.5	61 ± 7	170 ± 40

Appendix 3. Values of response variables in different experiments of 100% whole grain flour (WF) trial

Exp.	Independent process variables			Response variables				
	Water content of mass (%)	Screw speed (rpm)	Feed rate (g/min)	Torque (Nm)	Pressure (bar)	Water content of extrudates (%)	Expansion (%)	Hardness (N/mm)
1	16	240	76	49 ± 2	69 ± 5	12.0 ± 0.1	18 ± 3	230 ± 50
2	16	500	76	44 ± 1	50 ± 9	9.7 ± 0.1	51 ± 4	170 ± 30
3	16	370	68	42 ± 2	54 ± 6	11.0 ± 0.0	32 ± 5	210 ± 50
4	16	370	84	43 ± 2	45 ± 6	13.0 ± 0.1	30 ± 4	190 ± 30
5	18	240	68	47 ± 1	49 ± 6	14.2 ± 0.0	14 ± 2	230 ± 30
6	18	240	84	49 ± 2	47 ± 6	15.4 ± 0.1	14 ± 2	210 ± 30
7	18	500	68	39 ± 1	39 ± 7	11.6 ± 0.0	40 ± 4	170 ± 40
8	18	500	84	42 ± 2	42 ± 7	12.4 ± 0.1	39 ± 5	180 ± 20
9	20	240	76	45 ± 2	39 ± 5	16.8 ± 0.0	7 ± 2	200 ± 20
10	20	500	76	35 ± 1	34 ± 5	14.7 ± 0.1	29 ± 4	160 ± 30
11	20	370	68	42 ± 2	37 ± 6	14.5 ± 0.1	21 ± 2	190 ± 10
12	20	370	84	42 ± 2	38 ± 5	15.8 ± 0.0	16 ± 4	190 ± 50
13	18	370	76	44 ± 1	44 ± 6	13.4 ± 0.4	24 ± 3	210 ± 50
14	18	370	76	43 ± 2	42 ± 6	13.5 ± 0.0	23 ± 4	200 ± 20
15	18	370	76	47 ± 1	48 ± 6	13.0 ± 0.2	26 ± 3	190 ± 20

Appendix 4. β -glucan analysis of extrudates processed at same extrusion condition

$$\beta\text{-glucan (\%)} = \Delta\text{Abs} \cdot \frac{F}{W} \cdot 8.46 = \frac{\Delta\text{Abs} \cdot 100}{\text{Abs (100 } \mu\text{l of Glucose)} \cdot m \text{ (mg)}} \cdot 8.46$$

$$\beta\text{-glucan content (as is basis)} = \Delta\text{Abs} \times F \times 94 \times 1/1000 \times 100/W \times 162/180 = \Delta E \times F/W \times 8.46$$

Where, ΔAbs = Absorbance of reaction solution (i.e. after β -glucosidase treatment minus blank absorbance for same sample)

$$\Delta\text{Abs} = \text{Abs (sample, average)} - \text{Abs(blank)}$$

F = Factor to convert absorbance values to micrograms of glucose

= 100 (μg of glucose)/absorbance values for 100 μg of glucose

94 = Volume correction factor (0.1 of solution from 9.4 ml was analyzed)

1/1000 = Conversion from micrograms to milligrams

100/W = Conversion to 100 mg of sample

W = Sample weight in milligrams

162/180 = Factor to convert from free glucose, as determined, to anhydro glucose, as occurs in β -glucan.

β -glucan contents on dry weight basis, using equation:

$$\beta\text{-glucan (dry weight)} = \beta\text{-glucan (as is)} \times 100/100 - \text{moisture content, \%}$$

Data obtained from β -glucan analysis

Sample	Measured abs. (avg.)	Constant	Fresh-weight (mg)	Glucose control abs.	Constant	β -glucan fresh	Dry mass	β -glucan dry	β -glucan dry (avg.)	Stdev
Barley flour control, water content 10.49% (Megazyme)						4.1% β -glucan (Dry weight)				
Control a	0.216	100	49.0	1.168	8.46	3.186	89.1	3.575	3.7	0.24
Control b	0.238	100	49.3	1.168	8.46	3.489	89.1	3.916		
Oat flour control, water content 10.72% (Megazyme)						8.8% β -glucan (Dry weight)				
Control a	0.485	100	49.2	1.168	8.46	7.140	89.3	7.996	8.2	0.32
Control b	0.516	100	49.5	1.168	8.46	7.543	89.3	8.447		
Samples (not diluted)	Measured abs. (avg.)	Constant	Fresh-weight (mg)	Glucose control abs.	Constant	β -glucan fresh	β -glucan (avg.)		Stdev	Dev (%)
1. EF	0.091	100	49.5	1.168	8.46	1.332	1.33		0.003	0.245
	0.092	100	49.6	1.168	8.46	1.336				
2. WF	0.333	100	49.7	1.168	8.46	4.846	4.71		0.192	4.071
	0.312	100	49.4	1.168	8.46	4.575				
3. EF+OBC	0.269	100	49.3	1.168	8.46	3.945	4.15		0.292	7.031
	0.299	100	49.7	1.168	8.46	4.358				
4. EF+UBC	0.303	100	49.3	1.168	8.46	4.444	4.37		0.105	2.399
	0.293	100	49.4	1.168	8.46	4.296				
5. EF+EBC	0.274	100	48.9	1.168	8.46	4.059	4.15		0.124	2.989
	0.287	100	49.1	1.168	8.46	4.234				
6. EF+PC	0.109	100	49.1	1.168	8.46	1.601	1.6		0.004	0.218
	0.11	100	49.4	1.168	8.46	1.606				
7. EF+OBC+CS	0.438	100	49.7	1.168	8.46	6.376	6.3		0.113	1.799
	0.421	100	49.0	1.168	8.46	6.216				
8. EF+OBC+WS	0.437	100	49.0	1.168	8.46	6.460	6.56		0.138	2.111
	0.453	100	49.3	1.168	8.46	6.656				
9. EF+BC+CS+PC	0.436	100	49.4	1.168	8.46	6.385	6.38		0.013	0.205
	0.436	100	49.6	1.168	8.46	6.367				