

Pharmaceutical Technology Division
Department of Pharmacy
University of Helsinki
Finland

CONTROLLED TRANSDERMAL DRUG DELIVERY BY
IONTOPHORESIS AND ION-EXCHANGE FIBER

Tarja Kankkunen

ACADEMIC DISSERTATION

To be presented with the permission of the Faculty of Science of the University of Helsinki, for public criticism in Auditorium 1041 of Biocentre Viikki (Viikinkaari 5E), on September 7th, 2002, at 12 o'clock noon.

HELSINKI 2002

Supervisor: Professor Jouni Hirvonen
Pharmaceutical Technology Division
Department of Pharmacy
University of Helsinki
Finland

Reviewers: Professor Kristiina Järvinen
Department of Pharmaceutics
Faculty of Pharmacy
University of Kuopio
Finland

D.Sc. Lasse Murtomäki
Laboratory of Physical Chemistry and Electrochemistry
Helsinki University of Technology
Finland

Opponent: Professor Jukka Mönkkönen
Department of Pharmaceutics
Faculty of Pharmacy
University of Kuopio
Finland

© Tarja Kankkunen 2002
ISBN 952-10-0313-8 (print)
ISBN 952-10-0314-6 (pdf, <http://ethesis.helsinki.fi>)
ISSN 1239-9469

Yliopistopaino
Helsinki 2002
Finland

ABSTRACT

Kankkunen, T., 2002. *Controlled transdermal drug delivery by iontophoresis and ion-exchange fiber*.

Dissertationes Biocentri Viikki Universitatis Helsingiensis 17/2002, pp. 57
ISBN 952-10-0313-8 (print) ISBN 952-10-0314-6 (pdf) ISSN 1239-9469

A common aim in the development of new transdermal devices is the controlled delivery of drugs, so that the rate of drug input into the blood stream is predictable and reproducible. The transdermal therapeutic systems act as drug reservoirs and control the penetration rate of the drug into the skin and subsequent permeation into the blood circulation. Obviously, the release of the drug from the device can be controlled more exactly than the permeability of drugs in the skin. The outermost layer of the skin, *stratum corneum*, is usually the rate-limiting step in the permeation of drugs through the skin. Passive permeability of drugs across this layer is especially difficult to compounds which are hydrophilic, very lipophilic, of high molecular weight or charged. Iontophoresis is a process, by which the transport of ions into and through the skin is increased by the application of an external electric field across the skin.

One alternative to achieve controlled transdermal drug delivery is binding the drug into an ion-exchange fiber. Ion-exchange fibers consist of a polymeric framework, into which the ionic groups (e.g. $-\text{COO}^-$, NH_3^+) are bound. Controlled drug delivery by the ion-exchanger may be achieved by manipulating the properties of drug, ion-exchanger and/or external solution in the device.

In the present study, the effects of drug properties (six model drugs), fiber properties (six anion- and cation-exchange fibers), and medium properties (ionic strength, pH, volume, salt choice) on the drug binding into and drug release from the fibers were determined. Drug release from the fibers, with and without iontophoresis, and fluxes of the drugs across human *stratum corneum* were investigated *in vitro*. Drug stability in the ion-exchange fiber formulations was studied as well. Iontophoretic delivery of tacrine from a solution formulation and an ion-exchange fiber formulation was compared *in vivo* in healthy human volunteers. Finally, permeation of tacrine *in vitro* was compared to the *in vivo* results.

The binding and release of drugs into/from the ion-exchange fibers depends on a specific combination of the drug, fiber, and the concentration and nature of the external electrolyte. The distribution equilibrium of the drug is affected by drug-fiber interactions, which are specific to the ion-exchange group and the fiber nature. *In vitro* permeation of tacrine across the skin was directly related to the iontophoretic current density and to the drug concentration used. As the drug has to be released from the ion-exchanger before permeating across the skin, a clear reduction in the drug fluxes from the ion-exchange fibers were observed as compared to the corresponding fluxes of the drugs from solution. Ion-exchange fiber also improved the stability of easily oxidised levodopa during storage in water. Iontophoretic current and ion-exchange fiber may be used to control tacrine permeation across the skin and to achieve clinically relevant plasma concentrations with minor irritation on the skin. The *in vitro* and *in vivo* correlation of tacrine permeation was dependent on the experimental conditions and device structure.

In conclusion, cation- and anion-exchange fibers were shown to be promising materials to form a drug reservoir and to control the drug release from an iontophoretic transdermal system. By optimal selection of the external conditions (ionic-strength, pH, and salt), the drug properties (charge, lipophilicity, molecular weight), and the fiber quality (ion-exchange groups, capacity), one could achieve controlled release kinetics of a drug from the ion-exchange fiber and, subsequently, controlled transdermal drug permeation.

TABLE OF CONTENTS

| | |
|---|------------|
| TABLE OF CONTENTS | I |
| ACKNOWLEDGEMENTS | III |
| ABBREVIATIONS | V |
| ORIGINAL PUBLICATIONS | VI |
| 1 INTRODUCTION | 1 |
| 2 REVIEW OF LITERATURE | 2 |
| 2.1 TRANSDERMAL DRUG DELIVERY | 2 |
| 2.2 ENHANCEMENT OF TRANSDERMAL PERMEATION | 4 |
| 2.2.1 <i>General aspects</i> | 4 |
| 2.2.2 <i>Iontophoresis</i> | 6 |
| 2.3 ION-EXCHANGE FIBERS | 8 |
| 2.3.1 <i>General aspects</i> | 8 |
| 2.3.2 <i>The structure</i> | 9 |
| 2.3.3 <i>Theory of ion-exchange</i> | 11 |
| 2.3.4 <i>Characterization of drug delivery systems based on ion-exchange</i> | 13 |
| 2.3.5 <i>Ion-exchange fiber vs. resin</i> | 17 |
| 3 AIMS OF THE STUDY | 18 |
| 4 EXPERIMENTAL | 19 |
| 4.1 MATERIALS (I-IV) | 19 |
| 4.2 SUBJECTS (III) | 20 |
| 4.3 METHODS (I-IV)..... | 21 |
| 4.3.1 <i>Preparation of the drug containing ion-exchange fiber discs/bundles (I-IV)</i> ... | 21 |
| 4.3.2 <i>Drug release studies (I, II, IV)</i> | 22 |
| 4.3.3 <i>Source and preparation of skin (I, IV)</i> | 23 |
| 4.3.4 <i>Transdermal permeation experiments in vitro (I, III, IV)</i> | 23 |

| | |
|---|-----------|
| 4.3.5 Transdermal permeation experiments <i>in vivo</i> (III) | 25 |
| 4.3.6 Analysis of the drugs (I-IV) | 27 |
| 4.3.7 Statistical analyses (III) | 28 |
| 5 RESULTS AND DISCUSSION | 29 |
| 5.1 DRUG BINDING/ADSORPTION INTO THE ION-EXCHANGE FIBERS (I, II, IV)..... | 29 |
| 5.2 CONTROL OF DRUG RELEASE FROM THE ION-EXCHANGE FIBERS (I, II, IV) | 32 |
| 5.3 DRUG STABILITY (IV)..... | 36 |
| 5.4 DRUG PERMEATION STUDIES <i>IN VITRO</i> (I, III, IV)..... | 37 |
| 5.4.1 Drug permeation from solution formulations (I, IV)..... | 37 |
| 5.4.2 Drug permeation from ion-exchange fibers (I, III, IV) | 39 |
| 5.5 DRUG PERMEATION STUDIES <i>IN VIVO</i> (I, III) | 42 |
| 5.5.1 Transdermal delivery of tacrine for systemic use (I) | 42 |
| 5.5.2 Controlled transdermal delivery of tacrine <i>in vivo</i> (III) | 42 |
| 6 CONCLUSIONS | 47 |
| 7 REFERENCES..... | 48 |

ACKNOWLEDGEMENTS

This study was carried out at the Department of Pharmaceutics, University of Kuopio (I, II) and the Pharmaceutical Technology Division, Department of Pharmacy, University of Helsinki (III, IV) during the years 1998-2002.

I express my warmest gratitude to my supervisor professor Jouni Hirvonen for introducing me to the interesting world of the transdermal drug delivery, for guidance and endless optimism during these years. I also thank him for understanding my time-consuming sport “hobby” and my character of an ostrobothnian.

My special thanks go to the official manuscript reviewers, professor Kristiina Järvinen and Lasse Murtomäki (D.Sc.) for their critical reading of my thesis and for the valuable comments.

I wish to express my gratitude to professor Arto Urtti, the Head of Department of Pharmaceutics and to professor Jouko Yliruusi, the Head of the Pharmaceutical Technology Division for providing the excellent facilities for my work.

My sincerely thanks go to professor Arto Urtti for his expertise and supervision in the whole area of Pharmacy, professors Kyösti Kontturi and José A Manzanares for their expertise in physical chemistry and Kenneth Ekman (D.Sc.) and Mats Sundell (D.Sc.) for their expertise in chemistry. I wish to thank all of them for ideas and co-operation during the study.

My thanks go to our co-authors professor Raimo Sulkava and Marja Vuorio (M.Sc.), and to M.Sc. thesis student Inkeri Huupponen. I wish to thank Lea Pirskanen, Raija Ahlfors and Katri Lahtinen for their excellent technical assistance.

I am grateful to the whole staff of Department of Pharmaceutics (University of Kuopio) and Pharmaceutical Technology Division (University of Helsinki) for providing me the

most convenient and unforgettable moments at the working time and at the free time. I wish to thank especially Johanna and Kaisa for their friendship and for sharing the moments of both joy and despair. I thank also Merja and Marika for the pleasant moments especially in congress-travels.

I express my thanks to all my friends (Katsu, Pia, Heli, Sari, Kati and others) for their friendship and for taking my mind out of the work from time to time.

I thank my parents, Terttu and Heikki, and sister, Elina, for their unfailing encouragement and loving support during my whole life.

Finally, my warmest thanks belong to my dear husband Jarkko for his neverending love and understanding support, and my little girl, Laura, for being the sunshine of my life.

The financial support from Graduate School in Pharmaceutical Research, The National Technology Agency in Finland (TEKES) is gratefully acknowledged. Smoptech Ltd. and Novagent Inc. are acknowledged for a pleasant co-operation during the “Ion-exchange fiber”-project. The Finnish Pharmaceutical Society and The Finnish Pharmacists Association are also acknowledged.

Järvenpää, August 2002

ABBREVIATIONS

| | |
|--------------------------|--|
| A | surface area |
| ACN | acetonitrile |
| C_{ss} | steady-state concentration |
| CL | clearance |
| D | diffusion coefficient |
| E | enhancement factor |
| ED | <i>epidermis</i> and <i>dermis</i> |
| F | Faraday constant |
| HEPES | N-2-hydroxyethylpiperazine-N-2-ethanesulphonic acid |
| HPLC | high performance liquid chromatography |
| HSA | heptane sulphonic acid |
| J | flux |
| J_{ss} | steady-state flux |
| K_a | dissociation constant |
| $K_{c,d}$ | chemical partition coefficient |
| $K_{e,d}$ | electrical partition coefficient |
| LHRH | leutinizing hormone releasing hormone |
| LSC | liquid scintillation counter |
| MeOH | methanol |
| MW | molecular weight |
| P_{oct} | octanol/water partition coefficient |
| pKa | negative logarithm of dissociation constant |
| R | gas constant |
| T | absolute temperature |
| TEA | triethylamine |
| z | charge |
| SC | stratum corneum |
| SD | standard deviation |
| Smopex [®] -101 | poly(ethylene-g-styrene sulphonic acid) fiber |
| Smopex [®] -102 | poly(ethylene-g-acrylic acid) fiber |
| Smopex [®] -103 | poly(ethylene-g-vinylbenzyltrimethyl-ammoniumchloride) fiber |
| Smopex [®] -105 | poly(ethylene-g-vinylpyridine) fiber |
| Smopex [®] -107 | poly(ethylene-g-acrylic acid-co-vinyl sulphonic acid) fiber |
| Smopex [®] -108 | amidoxime functional fiber |
| μ | chemical potential |
| ϕ | electrical potential |

ORIGINAL PUBLICATIONS

This study is based on the following publications:

- I Jaskari T, Vuorio M, Kontturi K, Urtti A, Manzanares JA, Hirvonen J, Controlled transdermal iontophoresis by ion-exchange fiber. *J. Control. Rel.* 67: 179-190, 2000
- II Jaskari T, Vuorio M, Kontturi K, Manzanares JA, Hirvonen J, Ion-exchange fibers and drugs: An equilibrium study. *J. Control. Rel.* 70: 219-229, 2001
- III Kankkunen T, Sulkava R, Vuorio M, Kontturi K, Hirvonen J, Transdermal iontophoresis of tacrine *in vivo*, *Pharm. Res.* 19: 705-708, 2002
- IV Kankkunen T, Huupponen I, Lahtinen K, Sundell M, Ekman K, Kontturi K, Hirvonen J, Improved stability and release control of levodopa and metaraminol using ion-exchange fibers and transdermal iontophoresis. *Eur. J. Pharm. Sci.* in press 2002

1 INTRODUCTION

Transdermal drug delivery is an alternative route for systemic drug delivery. It offers many important advantages over oral drug delivery, e.g., avoids gastrointestinal tract and hepatic first-pass biotransformation and metabolism, controls absorption rate, increases patient compliance, and enables fast termination of drug delivery if needed (Singh and Maibach, 1994; Sathyan et al., 1995; Berti and Lipsky, 1995). A common aim in the development of new transdermal devices is the controlled delivery of drugs, so that the rate of drug input into the blood stream is predictable and reproducible. The transdermal therapeutic systems act as drug reservoirs and control the penetration rate of the drug into the skin and subsequent drug permeation into the blood circulation. When the device controls the transdermal drug flux instead of the skin, delivery of the drug is more reproducible leading to smaller inter- and intrasubject variations. Obviously, release of the drug from the device can be controlled more exactly than the permeability of drugs across the skin (Guy and Hadgraft, 1992). The permeability barrier of the skin changes with age and anatomical site (Bach and Lippold, 1998) and, therefore, the problem of variable *in vivo* drug absorption is common in both the passive and iontophoretic drug delivery, and this restricts the use of transdermal therapeutic systems (Guy and Hadgraft, 1992; Fiset et al., 1995).

One alternative to achieve controlled transdermal drug delivery is binding of the drug into an ion-exchange fiber (Hänninen et al., 2001). Charged drugs are bound into the ion-exchange groups until released by mobile coions. Complexation of drugs with ion-exchange resins has been studied as a promising means of achieving controlled drug release (Conaghey et al., 1998a; 1998b), enhanced drug stability (Jani et al., 1994; Conaghey et al., 1998a) and drug delivery (Irwin et al., 1990). Selection of 1) external conditions (e.g., ionic-strength, pH, and choice of salt in the release solution), 2) drug properties (charge, lipophilicity and molecular weight) and 3) fiber quality (ion-exchange groups, capacity), affect the release kinetics of a drug from ion-exchange systems. Conaghey et al. (1998a; 1998b) used a hydrogel containing ion-exchange resins to transport nicotine across the skin. They observed that binding of nicotine into the ion-

exchange resins makes the gel formulations unsuitable for passive transdermal drug delivery. However, iontophoretic current was observed to enhance the rate of nicotine delivery from the ion-exchange resins considerably (Conaghey et al., 1998b). As with resins, the major interest in the use of ion-exchange fibers in formulation development is to provide a controlled drug adsorption/binding into the fiber and to create a stable drug reservoir during storage. A controlled release profile and predetermined drug absorption from the transdermal drug delivery system may then be attempted by optimizing the properties of the ion-exchange fiber(s) and electrical current (iontophoresis).

The specific objectives of this work were to study the properties and utilization of ion-exchange fibers in controlled transdermal drug delivery, and to determine, whether therapeutically relevant plasma concentrations of a model drug, tacrine, could be achieved using iontophoretic transdermal drug delivery in healthy human volunteers.

2 REVIEW OF LITERATURE

2.1 Transdermal drug delivery

Transdermal drug delivery systems have been existing for a long time. In spite of major research and development efforts in transdermal systems and the many advantages of the transdermal route, there still are some problems that limit the clinical use of the transdermal approach. The disadvantages of transdermal systems are, that drugs, which require high-blood levels can not be administered, drug or drug formulation may cause skin irritation or sensitization, it may be uncomfortable to use, and the system is not economical (Guy and Hadgraft, 1989; Ranade, 1991; Berti and Lipsky, 1995). The transport of drugs through the skin is complex since many factors influence their permeation. These factors are 1) skin structure and its properties, 2) the penetrating molecule and its physico-chemical properties, 3) delivery system carrying the penetrant, and 4) the combination of skin, the penetrating molecule and the delivery system (Ranade, 1991). Benefits of transdermal drug delivery include bypass of the hepatic first pass effect and gastrointestinal side effects, controlled plasma levels of potent drugs with

short biological half-lives, increased patient compliance, allowed administration of drugs with narrow therapeutic window, and ease of terminating drug delivery if toxicities occur. This noninvasive drug delivery system also minimizes trauma, risk of infection, damage to the wound, and it is an important alternative to parenteral infusion (Singh and Maibach, 1994; Ranade, 1991; Berner and John, 1994).

The skin is a multilayered organ that is complex in both the structure and function (Walters, 1989). At physiological pH human skin has a net negative charge (Burnette, 1988). The skin is composed of the *epidermis*, *dermis*, and underlying subdermal tissue. The *epidermis* is composed of five layers of cell types, beginning from the skin surface: *stratum corneum*, *stratum lucidum*, *stratum granulosum*, *stratum spinosum*, and *stratum basale* (Berti and Lipsky, 1995). The major barrier to drug penetration and permeation in the skin is the *stratum corneum*, a dead layer of tissues. The majority of human *stratum corneum* lipids consist of ceramides and neutral lipids such as free sterols, free fatty acids, and triglycerides. Structure of the *stratum corneum* is that of a rigidly arranged and lipophilic membrane, which forms the most impermeable membrane in humans (Guy and Hadgraft, 1989). There is no active transport across the skin (Hadgraft, 1996). The *stratum corneum* offers three possible routes of drug permeation, transcellular (through cells), intercellular (between cells) and appendageal (via the sweat glands, hair follicles and sebaceous glands) pathways (Cullander, 1992; Prausnitz, 1996a). Small (MW < 400 g/mol) lipophilic (log P_{oct} 2-3) molecules permeate passively mostly by the intercellular path between the corneocytes. Also the passive flow of charged and polar molecules occurs dominantly via the intercellular pathway. Iontophoretic flow of large, hydrophilic and charged molecules occurs mainly through the skin appendages (Cullander, 1992; Turner and Guy, 1997). Since appendages make up a very small percentage of the total skin surface (about 0.1 %), ion transport may also occur via the intercellular path in both the passive and iontophoretic transport (Singh et al., 1998).

Transdermal drug delivery can be described in three principal stages: 1) delivery of the molecule to the skin surface, 2) passage of the molecule through the skin, and 3) distribution of the molecule into the site of action via the systemic circulation. Either step

1 or 2 is the permeation rate limiting step. In the passive delivery the transport of the molecule across the *stratum corneum* is the rate limiting factor. Controlled transdermal delivery systems are developed so that the diffusion of drug in the polymer membrane of the product is the rate limiting step (Guy and Hadgraft, 1992; Berti and Lipsky, 1995; Wang et al., 1998; Ocak and Ağabeyoğlu, 1999). Controlled drug delivery is generally achieved by manipulating the properties of drugs and/or drug delivery devices or carriers. When the device controls the transdermal drug flux instead of the skin, delivery of the drug is, presumably, more reproducible.

2.2 Enhancement of transdermal permeation

2.2.1 General aspects

Many of the drugs under study have not any great abilities to cross the skin, and ways must be found to modify the diffusional barrier or to increase drug permeation by another way (Walters, 1989). Passive permeation across the *stratum corneum* is especially difficult to compounds which are hydrophilic ($\log P_{\text{oct}} < 1$), very lipophilic ($\log P_{\text{oct}} > 3$), of high molecular weight ($MW > 400 \text{ g/mol}$) or charged. Generally, methods to enhance transdermal drug permeation can be grouped into two categories: chemical methods and physical methods. Chemical enhancers and prodrugs have been found to increase transdermal drug transport via several different mechanisms, including increased solubility of the drug in the donor formulation, increased drug partitioning into the *stratum corneum*, fluidization of the lipid bilayers, and disruption of the intracellular proteins (Barry, 1987; Aungst et al., 1990; Rautio et al., 1998). It is obvious that many different groups of chemicals have the potential to alter the barrier properties of skin (Walters, 1989; Suhonen et al., 1999). Many of the chemical enhancers are irritants and, therefore, methods which are safe and effective are under development. The prodrugs are pharmacologically inactive drug molecules, which require a chemical or enzymatic transformation to release the active parent molecule (Rautio et al., 1998). Prodrugs have been used to improve the delivery of drug across the skin, because a lot of nonspecific esterases and other enzymatic activity are present in the epidermis. However, high

prodrug concentration in the skin may lead to enzyme saturation, which hinders the conversion of a prodrug into an active drug molecule.

In order to control the drug delivery across the skin more precisely, physical methods have been tested to create effective transdermal drug delivery (Bellantone et al., 1986; Rolf, 1988; Burnette, 1988; Prausnitz et al., 1996b; Mitragotri, 2001; Lin et al., 2001). Phonophoresis or sonophoresis refers to the use of (low-frequency) ultrasound for enhancing percutaneous absorption of various therapeutic agents. Iontophoresis and electroporation use electrical current/voltage to deliver charged or uncharged molecules into the skin (Rolf, 1988). Electroporation involves the creation of transient aqueous pathways in the lipid bilayer membrane by the application of a short electric field pulse (Prausnitz, 1998). Two main pulse protocols have been employed to promote transport; intermittent application of short high-voltage pulses (about 1 ms and 100 V across the skin) and a few applications of long medium-voltage pulses (about 100 ms and > 30 V across the skin) (Vanbever et al., 1999). Iontophoresis is a process in which the transport of ions into or through the skin is increased by the application of an external electric field across the human skin. The constant current density used is 0.5 mA/cm² at maximum (no unbearable pain or prolonged skin irritation) (Ledger, 1992). Iontophoresis uses the potential difference between two electrodes to transport solutes. The use of iontophoretic current has been shown to enhance significantly the rate of drug delivery from a transdermal device over the corresponding passive transport (Burnette, 1988). The mechanisms of iontophoresis and electroporation appear to be completely different. In iontophoresis the flux is related to the total charge transported through the system, while electroporative voltage pulses produce transient permeabilization of the *stratum corneum*, and the transport can not be related to the amount of charge passed across the skin (Bommannan et al., 1994; Prausnitz, 1998). The interest in the physical enhancement methods has increased as a potential way to deliver noninvasively new drugs that have been produced by novel biotechnological methods (peptides, oligonucleotides, genes) (Table 1).

Table 1. Methods to enhance transdermal permeability of (macromolecular) drugs. Methods are more or less in the order of increasing invasiveness (modified from Hirvonen and Jaskari, 2001).

| Method | Mode of action |
|--------------------------|---|
| Chemical enhancers | Compromisation of the tightly structured <i>stratum corneum</i> lipid bilayers |
| Lipid vesicles | Cumulation of drugs in the <i>stratum corneum</i> |
| Iontophoresis | Low current/voltage electrostatic repulsion, electroosmosis |
| Low-frequency ultrasound | Local thermal effect, weakened bilayers of the <i>stratum corneum</i> by cavitation |
| Electroporation | High voltage short term electrical pulses |
| (Micro)needles | Transient holes in the skin |
| Pressurised He-gas | Invasive “gene guns” |

2.2.2 Iontophoresis

Iontophoresis enhances transdermal drug delivery by three mechanisms: 1) the electrorepulsion (migration), which enhances only the flux of charged molecules (Burnette, 1988; Peck et al., 1998), 2) the electroosmotic solvent flow, which enhances the flux of both charged and neutral molecules (Burnette, 1988; Pikal, 1992), and 3) the increased permeability of skin by the flow of electric current. The applied potential difference across the skin can lead to alterations in the tissue permeability, which, nonetheless, typically has no great significance (Sugar, 1979; Teissie and Tsong, 1981; Benz and Zimmerman, 1981; Glaser et al., 1988; Sims et al., 1991). Potential difference across the skin between two opposite sign electrodes causes electrorepulsion of ions through the skin (Fig. 1). Electrorepulsion takes place due to the repulsion between the electrode and drug of the same sign. It is the most important mechanism in the iontophoresis of small drug molecules (Burnette, 1988). The significance of

electrorepulsion and electroosmosis depends on the physico-chemical and electrical properties of the membrane, and of the permeant (Lu et al., 1993; Delgado-Charro and Guy, 1994; Hoogstraate et al., 1994; Hirvonen et al., 1996; Guy et al., 2000).

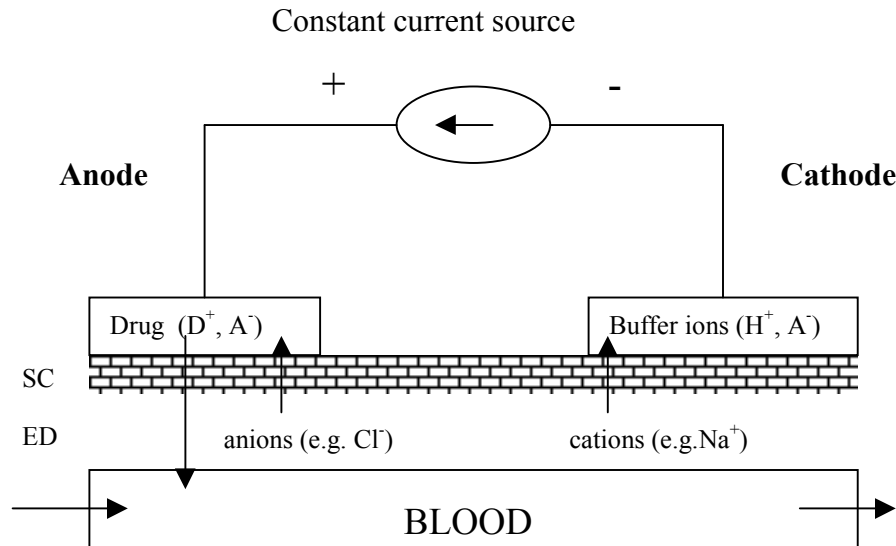

Figure 1. The principle of iontophoresis. The voltage drop across the brick-wall-like *stratum corneum* (SC) provides the potential gradient, which is the driving force of ions across the skin during the constant current iontophoresis. SC is a non-conductive lipophilic membrane and ED denotes the viable hydrophilic *epidermis* and *dermis* (modified from Guy, 1995).

Electroosmotic flow is bulk fluid flow, which occurs when an electrical field is applied across a charged membrane. Electroosmotic flow is always in the same direction as flow of counterions (from anode to cathode in the skin) and may either hinder or assist drug transport (Burnette, 1988). The role of electroosmotic flow in the transdermal iontophoretic permeation has been studied extensively (Burnette, 1988; Pikal, 1990; 1992; Delgado-Charro and Guy, 1994; Tamada et al., 1995; Rao et al., 1995; Santi and

Guy, 1996; Hirvonen et al., 1996; Hirvonen and Guy, 1997; Luzardo-Alvares et al., 1998; Marro et al., 2001). The amount of electroosmotic flow has been predicted by theoretical models (*e.g.*, limiting law analysis of electrical volume force, law of Manning (1967), Hildreth (1970), Gonzales-Tovar et al. (1991) and others (Pikal, 1990; 1992)). It has been demonstrated, that the electroosmotic flow can be modulated by the properties of permeant. It is generally accepted that the contribution of electroosmotic flux becomes greater, as compared to electrorepulsion, as the molecular size of an ion increases (Pikal, 1992). Lipophilic, cationic drugs, *e.g.*, LHRH-peptides and β -blocking agents, can evoke a dramatic effect on the permselective properties of human skin and on the extent and direction of the electroosmotic flow (Delgado-Charro et al., 1995; Hirvonen et al., 1996; Hirvonen and Guy, 1997). These lipophilic cations are able to become strongly associated with the net negative charge on the membrane, when iontophoresed at neutral pH 7.4 and, essentially, to stop completely the electroosmotic flow by neutralizing the charge of the skin membrane.

2.3 Ion-exchange fibers

2.3.1 General aspects

Ion-exchange products have several applications in pharmacy for controlled or sustained drug delivery. Adams and Holmes synthesized the first ion-exchange resins in 1935 (Adams and Holmes, 1935). From 1950's to the present the complexation of drugs with ion-exchange resins has been studied extensively (Chaudhry and Saunders, 1956; Burge et al., 1986; Irwin et al., 1987; 1990; Jani et al., 1994; Conaghey et al., 1998a; 1998b). The advantage of ion-exchange materials for controlled drug delivery is their ability to bind and exchange charged drug molecules. Several peroral ion-exchange products have been developed for sustained and controlled drug release (Chaudhry and Saunders, 1956; Burge et al., 1986; Irwin et al., 1987; 1990). An ocular delivery system which utilizes ion-exchange resins has also been commercialized (Joshi, 1994). Nasal drug delivery systems based on ion-exchange resins (delivery of nicotine, vaccines, peptides, proteins and enzymes) have been patented (Illum, 1996; Mizushima et al., 1996). Conaghey et al.

(1998a; 1998b) have studied the use of ion-exchange resins in passive and iontophoretic transdermal drug delivery. The benefits of the properties of ion-exchange fiber, as compared for example to resins, are good mechanical strength and chemical inertness, easy handling, extensive surface, and the possibility of achieving a very high capacity (in other words, a high extent of grafting) (Sundell and Näsman, 1993). The backbone of the fiber (*e.g.*, polyethylene, polypropylene) is grafted by radiation under an electron beam with a wanted substance (*e.g.*, polyacrylic acid, polyamine, polystyrene) (Ekman, 1994; Sundell et al., 1995; Mäki-Arvela et al., 1999). Graft polymerization offers a number of different possibilities to control drug adsorption into the fiber to form a drug reservoir, and to control the drug release from this reservoir. The ion-exchange capacity increases with the increasing amount of ion-exchange groups in the polymeric backbone. Typically, only a low fraction of the drug in the ion-exchanger is released and available for transport into the place of clinical effect. The higher the capacity of the fiber the more drug molecules are available to be released and permeated across the skin.

2.3.2 The structure

The most important class of ion-exchangers is the organic ion-exchange resins (Fig. 2a). They consist of a framework, a so called matrix, carrying a positive or negative electric fixed charge, which is compensated by mobile counter ions of opposite sign. A small amount of mobile ions of the same sign (coions) can also be present. The framework is typically a hydrophobic hydrocarbon chain. Ionic groups in the framework are such as $-\text{SO}_3^-$, $-\text{COO}^-$, $-\text{PO}_3^{2-}$, $-\text{AsO}_3^{2-}$ in cation-exchangers and $-\text{NH}_3^+$, $-\text{NH}_2^+$, $-\text{NH}^+$ and $-\text{S}^+$ in anion-exchangers (Helfferrich, 1995). The structure of an ion-exchange fiber is generally the same as in resins, but the resins have crosslinked grafted side chains which the fibers do not have (Fig. 2b) (Ekman, 1994). Ion-exchange fibers are like a cloth, with an arranged structure. Because of non-crosslinked structure, high molecular weight biomolecules may fit better and be bound into the ion-exchange groups and, thereafter, may be delivered to the site of action. On the other hand, cross-linking of the resin may hinder the movement of a molecule and, therefore, hinder the drug release from the binding sites.

a)

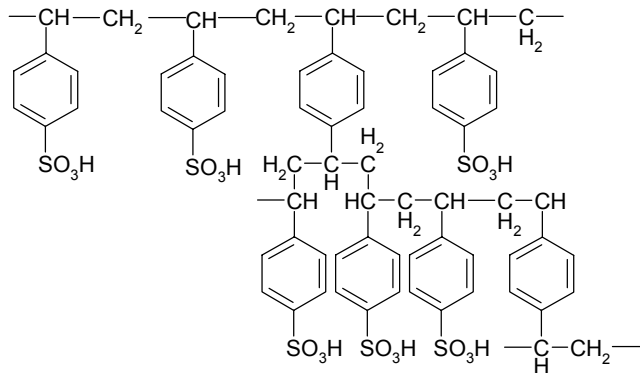

b)

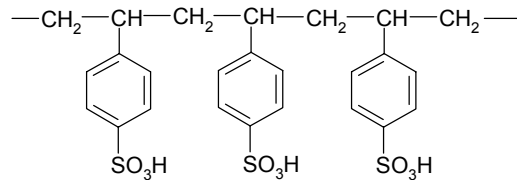

Figure 2. Schematic presentation of the structure of a) ion-exchange resin and b) ion-exchange fiber (modified from Ekman, 1994; Florence and Attwood, 1998).

In the ion-exchange resins the ions are known to be bound to the ion-exchanger by two mechanisms. The first layer of molecules is bound strongly via electrostatic bonds. These strong bonds have a chemical nature and only ionized molecules are capable to be bound to this layer, where the concentration of binding molecules is very high. The molecules bind to the second layer via loose interactions of hydrophobic nature. The hydrophobic interactions may also occur between the side chains of bound molecules. Both the ionized and non-ionized molecules will be present in the second layer (Conaghey et al., 1998b; Marchal-Heussler et al., 2000).

The chemical nature of the ion-exchange groups greatly affects the equilibrium of ion-exchange in the fiber. An important factor is the acid and base strengths of the active

groups. Weak acidic groups, such as $-\text{COO}^-$, are ionized only at a high pH. In contrast, strong acidic groups, e.g. $-\text{SO}_3^-$, are ionized even at a low pH. The physico-chemical properties of drugs and binding/dissolution medium affect also to the binding and releasing kinetics.

2.3.3 Theory of ion-exchange

Ion-exchange is a stoichiometric process in which any counter ions that leave the ion-exchanger are replaced by an equivalent amount of other counter ions (Fig. 3) (Raghunathan et al., 1981). This is a consequence of the electroneutrality requirement. The ion-exchange is essentially a diffusional process, but also has relation to chemical reaction kinetics. Usually the ion-exchangers are selective, they take up some counter ions in preference to others. The rate-determining step in ion-exchange is diffusion either within the ion-exchanger itself or in the diffusion boundary layer (Helfferich, 1995).

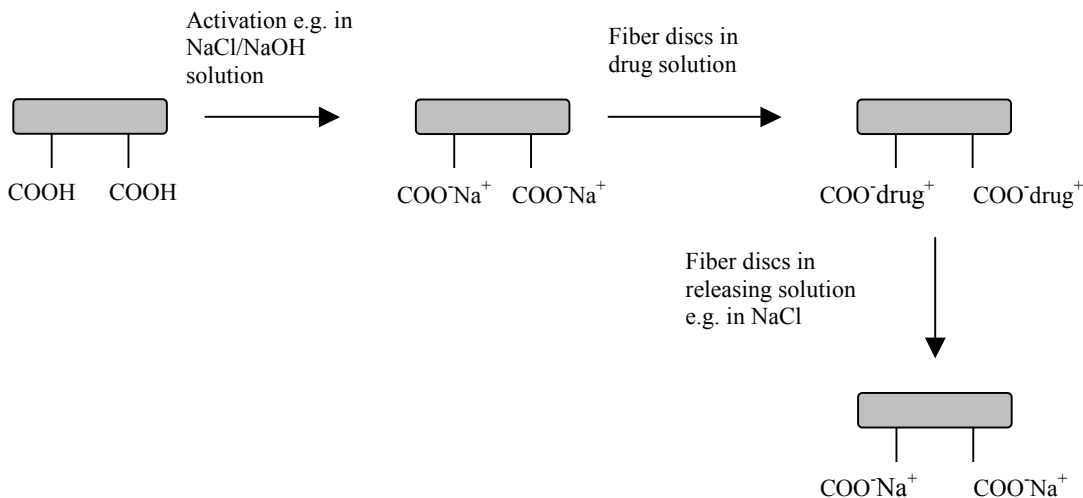

Figure 3. The principle of drug binding into the ion-exchange fiber and drug release from the fiber (modified from Åkerman, 1999).

The equilibrium distribution of the drug species between the fiber and external solution phases results from both electrostatic and hydrophobic interactions. The former are measured by the electrical partition coefficient ($K_{e,d}$) (Helfferich, 1995)

$$K_{e,d} = \exp(-z_d F \phi_D / RT) \quad (\text{Equation 1}),$$

where F , R , and T are the Faraday constant, the gas constant, and the absolute temperature, respectively, and $\phi_D \equiv \bar{\phi} - \phi$ (*i.e.*, the electrical potential in the ion-exchanger (overbar) with respect to the external phase) is the Donnan potential, which is determined by the ion-exchange capacity of the ion-exchanger and the nature and concentration of the external solution. In the case of cationic drugs (charge number $z_d > 0$) in cation-exchange membranes, ϕ_D is negative and $K_{e,d} > 1$. Similarly, the chemical partition coefficient ($K_{c,d}$) (Lyklema, 1991)

$$K_{c,d} = \exp[(\mu_d^0 - \bar{\mu}_d^0) / RT] \quad (\text{Equation 2}),$$

measures the tendency of the drug to get into the ion-exchanger as a result of the specific interaction of the drug with the hydrophobic ion-exchanger. In Eq. (2), μ_d^0 is the standard chemical potential of the drug species, and overbars denote the ion-exchanger phase. The more hydrophobic the drug, the larger the decrease in free energy associated to its interaction with the ion-exchanger and the larger the value of $K_{c,d}$ (> 1). In the case of hydrophilic drugs, however, $K_{c,d}$ could be smaller than one. (The water content of the ion-exchanger also affects the value of $K_{c,d}$). Finally, the molar drug concentration ratio is (Laksminarayanaiah, 1984)

$$\frac{\bar{c}_d}{c_d} = K_{p,d} = K_{e,d} K_{c,d} \quad (\text{Equation 3}),$$

which results from the fact that the electrochemical potential of the drug species takes the same value in the ion-exchanger and external solution phases under equilibrium conditions (Donnan equilibrium).

2.3.4 Characterization of drug delivery systems based on ion-exchange

Using an ion-exchanger and iontophoresis one may presumably achieve controlled transdermal drug delivery. The most commonly used methods to control iontophoretic drug delivery across the skin are current density and donor drug concentration, both of which are directly related to the drug flux (Padmanabhan et al., 1990; Miller et al., 1990). Despite the relative attenuation in the extent of maximal drug delivery, additional and more precise control of transdermal iontophoresis is expected to be achieved by ion-exchange approach (Conaghey et al., 1998b). By changing the external conditions one may affect the drug release, but also the properties of the drug and ion-exchanger have an important role in the drug adsorption and drug release (Irwin et al., 1990; Jenquin et al., 1990; Conaghey et al., 1998a; 1998b; Åkerman et al., 1999).

Different drug adsorption methods have been developed to determine the amount of drug molecules in the ion-exchanger and the degree of ion-exchange in the pharmaceutical products (Benoit et al., 1994; Prot et al., 1996; Conaghey et al., 1998a; 1998b; Mäki-Arvela et al., 1999; Marchal-Heussler et al., 2000). Using dielectric measurements (dielectric loss, dielectric permittivity) one may determine the electrical properties of the ion-exchanger, and by the use of adsorption isotherms the amount of a drug in the ion-exchange material (Benoit et al., 1994; Prot et al., 1996; Marchal-Heussler et al., 2000). There are several different ways to determine the adsorption isotherm (Conaghey et al., 1998a; 1998b; Mäki-Arvela et al., 1999). Despite the differences in these determinations, the basic idea is the same: drug adsorbed into the ion-exchanger = total drug – free drug. Summary of the properties of drug, ion-exchanger and external solution, which all affect the binding and release kinetics of a drug from the ion-exchange system, is presented in Table 2.

Table 2. Effects of the properties of drug, ion-exchanger and external solution on the binding of a drug into and release kinetics from the ion-exchange system.

| Property | Effect | Reference |
|--|--|------------------------|
| pKa of the drug | => charged sites of drug | Hänninen et al., 2001 |
| pH of the solution | => charged sites of drug and ion-exchanger | Charman et al., 1991 |
| Lipophilicity of the drug | => binding affinity | Hänninen et al., 2001 |
| Drug concentration in the ion-exchanger | => amount of drug release | Conaghey et al., 1998b |
| Ion-exchange groups of the ion-exchanger | => binding affinity | Conaghey et al., 1998a |
| Degree of grafting | => extent of drug release depending on the properties of drug | Åkerman et al., 1998 |
| Particle size of the ion-exchanger | => adsorption capacity => drug release | Burge et al., 1986 |
| Ionic strength of the releasing solution | => drug release | Sawaya et al., 1988 |
| Medium of drug loading | => binding affinity => drug release | Jenquin et al., 1990 |
| Salt choice | => affinity of salt molecule to ion-exchange groups => drug release | Charman et al., 1991 |
| Crosslinking the hydrocarbon network of the ion-exchange resin | => drug release | Irwin et al., 1990 |
| Temperature of loading medium | => drug incorporation | Chen et al., 1996 |
| Temperature of releasing medium | => drug release | Irwin et al., 1990 |
| Stirring speed | => drug release | Chen et al., 1996 |

Due to the properties of the ion-exchanger and the drugs (*e.g.*, pKa), changes in the pH affect the binding and release of a drug. Proportion and number of charged sites in the drugs and ion-exchange groups change with pH. Hydrocarbon based backbone of the resin/fiber is hydrophobic and, thus, binding between the drug and the resin increases with increasing drug lipophilicity. It could be assumed that hydrophilic drugs were incorporated better into the ion-exchangers with a hydrophilic backbone (*e.g.*, viscose).

However, Hänninen et al. (2001) found no difference in the incorporation of ten salicylic acid derivatives ($\log P_{\text{oct}}$ varied from 1.5 to 3.0) into the ion-exchange fibers with hydrophilic (viscose) or hydrophobic (polyethylene) backbone. The increasing drug concentration in the resin/fiber increases also the amount of released drug. The fraction (percentage) of the drug release is the same by the same resin and drug (Conaghey et al., 1998b). However, the rate to reach this level was different depending on the drug concentration in question. The ion-exchange groups of the resin or fiber can be either strong or weak exchangers or a mixture of them both. A strong exchanger binds a drug strongly and it is released slowly. In contrast, a weak exchanger binds a drug weakly and, therefore, the drug is released quickly. The degree of grafting may obviously affect the drug release depending on the physico-chemical properties of the drug.

The binding strength of drugs into the ion-exchange systems is due to both the electrostatic and hydrophobic interactions (see section 2.3.3). Ion-exchange resins, which have a small particle size, bind and release significantly more drug (adsorption and release rates are also faster) than the resins with larger sized particles (Burge et al., 1986; Irwin et al., 1987; 1990; Conaghey et al., 1998b; Sriwongjanya and Dodmeier, 1998). The release of a drug could be increased or decreased by adjusting the degree of cross-linking of a resin. Both the small particle size and increase in the cross-linking in the resin leads to a large surface area to unit volume ratio, which causes higher adsorption with weak hydrophobic interactions. On the other hand, the increased cross-linking may hinder the movement of a drug through the resin and, thus, decrease the drug release. In general, increase in the ionic strength causes increase in the drug release (Irwin et al., 1987; Sawaya et al., 1988; Jenquin et al., 1990; Conaghey et al., 1998a). Increase in the electrolyte concentration decreases the Donnan potential and, hence, the electrostatic affinity between the drug and the ion-exchanger, thus tending to increase drug release (Åkerman et al., 1998). The ionic strength of the loading solution influences the drug binding and release from the ion-exchanger. If the drugs are loaded in pure water (as compared to a buffer medium), weaker interactions with the ion-exchange materials are observed and the drug release takes place more easily. Thus, the adsorption of the drug into the ion-exchanger is decreased with the increasing ionic strength of the buffer

medium (Jenquin et al., 1990; Conaghey et al., 1998b, Åkerman et al., 1999). This decrease in drug adsorption into the ion-exchanger may be due to the inhibition of electrostatic binding of the drug by the presence of other ions.

Due to the different affinity of molecules to the ion-exchanger, the molecules in the external solution also affect the drug release. For example, calcium ions are known to adsorb more strongly than sodium ions, especially to carboxylic groups (Sawaya et al., 1988; Charman et al., 1991; Sørensen and Rivera, 1999). Generally, increasing the charge of the salt increases the binding affinity into the ion-exchange groups, which obviously increases the drug release (Helfferrich, 1995). However, increase in the charge density of ion-exchange material may crosslink the hydrocarbon network of the resin and, thereby, hinder drug release (Kriwet and Kissel, 1996). If one considers transdermal drug delivery, several salt molecules may cause skin irritation and, therefore, one may use only few additive salts on the skin. Optimization of the external coion concentrations so that all the coions bind into the ion-exchanger will, however, prevent the irritation effect of the salt.

In ion-exchange fibers, the rate of ion-exchange has been found to rise with the increase of temperature (Chen et al., 1996). Other researches have observed the same with resins (Irwin et al., 1990; Jenquin et al., 1990). The observation can be explained as the increased molecular movement caused by the increased temperature. Although the changes in temperature may affect the drug release, the temperature of a transdermal drug delivery device may not differ considerably from a physiological temperature on the skin. The temperature has also an effect on the incorporation of a drug into the resin. Drug loading at a higher temperature provides a lower release rate despite the greater drug content in the resin (Irwin et al., 1990). Drug ions penetrate probably into deeper exchange centers in the resin due to the heat. The ion-exchange rate increases also with the increase of stirring speed (Irwin et al., 1990; Chen et al., 1996). When the stirring speed increases, the thickness of the adherent film decreases, and this in turn leads to the increase in the ion-exchange rate.

2.3.5 Ion-exchange fiber vs. resin

Ion-exchange material may consist of, *e.g.*, ion-exchange resin, gel or fiber (Jones et al., 1989; Irwin et al., 1990; Jenquin et al., 1990; Chen et al., 1996; Lin and Hsieh, 1996; Conaghey et al., 1998a; 1998b). Ion-exchange resins and gels have crosslinked grafted side chains, which the fibers do not have (Fig. 2) (Ekman, 1994; Helfferich, 1995). Drug release kinetics from the previous ion-exchangers differ from each other (Chen et al., 1996). Drugs were released significantly faster and to a larger extent from the ion-exchange fibers than from the gel or resin. The most ion-exchange processes in resin and gel are controlled by particle diffusion (Lin and Hsieh, 1996). This is also the case for the fiber. Chen et al. (1996) assumed that the enhanced rate of ion-exchange in the fiber is due to the smaller shell thickness of the fiber as compared to the shell thickness of a resins. Small shell thickness of the fiber allows the ions a rapid access to the ion-exchange groups. Also, ion-exchange fiber (especially the staple fiber) is suggested to have a larger surface area to unit volume ratio, which leads to a higher adsorption rate and adsorption capacity (and, presumably, also to a higher release rate as compared to the resin or gel). Furthermore, one could easily presume, that molecules with high molecular weight could be incorporated more easily into the ion-exchange fiber than into the resins or gels that include cross-linked grafted side chains. Thus, cross-linking could hinder the incorporation (and release) of biomolecules into (from) the resin.

3 AIMS OF THE STUDY

The main purpose of this study was to investigate the properties of the cation- and anion-exchange fibers to store drugs and to deliver drugs transdermally. The specific aims can be summarized as follows:

- 1) To understand drug adsorption phenomena into the ion-exchange fibers.
- 2) To determine the kinetics of drug release from the fibers, especially to study the influence of external conditions, drug properties, and fiber quality on the drug release from the ion-exchange fibers.
- 3) To study the effect of ion-exchange fiber on drug stability.
- 4) To determine *in vitro* the flux of drugs through the human *stratum corneum*, with and without iontophoretic current, and the effect of ion-exchange fibers on that flux.
- 5) To determine, whether clinically relevant plasma concentrations of tacrine in human volunteers could be achieved using short-term iontophoretic transdermal drug delivery utilizing ion-exchange fiber approach.

4 EXPERIMENTAL

4.1 Materials (I-IV)

Tacrine(-HCl) (**I-III**), propranolol(-HCl) (**I, II**), nadolol (**I, II**), metaraminol (bitartrate salt) (**IV**), and zwitterionic levodopa (**IV**) were obtained from Sigma (St. Louis, MO, USA). Salicylic acid (sodium salt) (**I**) was from Aldrich-Chemie (Steinheim, Germany). Chemical structures and physico-chemical properties of the model drugs are presented in Table 3. N-2-hydroxyethylpiperazine-N-2-ethanesulfonic acid (HEPES for the buffer) (**I, IV**) and ethylenediaminetetraacetic acid (EDTA, chelating agent) (**IV**) were from Sigma (St. Louis, MO, USA). D(+)-mannitol, was obtained from Merck (Darmstadt, Germany) (**IV**) and the radiolabeled D-(1-¹⁴C)-mannitol (54,50 mCi/mmol, purity > 97 %) (**IV**) was from Dupont NEN[®] Products (Boston, USA). Deionized water (resistivity $\geq 18 \text{ M}\Omega\text{cm}^{-1}$) was used to prepare all the solutions. All the other chemicals were analytical grade and were used without further purification.

Cation-exchange fibers Smopex[®]-101 [-SO₃H ion-exchange groups, poly(ethylene-g-styrene sulphonic acid) fiber] (**II, IV**), Smopex[®]-102 [-COOH ion-exchange groups, poly(ethylene-g-acrylic acid) fiber] (**I-IV**) and Smopex[®]-107 [1:1 -COOH and -SO₃H ion-exchange groups, poly(ethylene-g-acrylic acid-co-vinyl sulphonic acid) fiber] (**II**) and anion-exchange fibers Smopex[®]-103 [trimethylammonium ion-exchange groups, poly(ethylene-g-vinylbenzyltrimethylammoniumchloride) fiber] (**IV**), Smopex[®]-105 [pyridine ion-exchange groups, poly(ethylene-g-vinylpyridine) fiber] (**IV**) and Smopex[®]-108 [-NH₂ ion-exchange groups, amidoxime functional fiber] (**I**) were obtained from Smoptech Ltd. (Turku, Finland). Maximal ion-exchange capacity of the 101-fiber was 3.2 (**II**) and 4.0 (**IV**) mmol/g, 102-fiber 8.0 (**I, II**) and 12 (**IV**) mmol/g, 107-fiber 8.0 mmol/g (**II**), 103-fiber 3.5 mmol/g (**IV**), 105-fiber 6.0 mmol/g (**IV**) and 108-fiber 3.4 mmol/g (**I**). Ion-selective Nafion[®] membrane, used in the *in vivo* permeation experiments (**III**), was purchased from ElectroCell AB (Täby, Sweden), and Durapore[®] porous membrane from Millipore (Ireland) (**III**).

Table 3. Physico-chemical properties of the drugs studied (Drayton, 1990):
 MW = molecular weight, K_a = dissociation constant, and P_{oct} = octanol/water
 partition coefficient. ^our determination

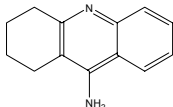
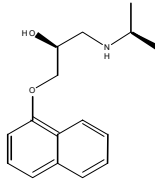
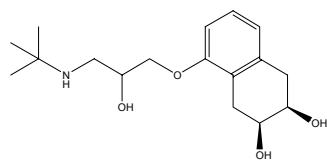
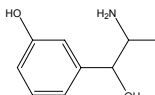
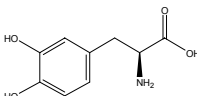
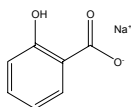
| Drug | MW (g/mol) | pK_a | $\log P_{oct}$ | molecule structure |
|-------------------|------------|------------------------|----------------|---|
| Tacrine | 198.0 | $9.8 \pm 0.2^{\wedge}$ | 3.3 |  |
| Propranolol | 259.1 | 9.23 | 3.2 |  |
| Nadolol | 309.4 | 9.39 | 0.9 |  |
| Metaraminol | 167.2 | 8.6 | -0.27 |  |
| Levodopa | 197.2 | 2.3; 8.7; 9.7; 13.4 | -2.9 |  |
| Sodium salicylate | 160.1 | 3.0 | 1.5 |  |

4.2 Subjects (III)

Ten healthy adult volunteers (5 males and 5 females) were included in the experiments (III). The age of the study subjects ranged from 19 to 52 years, and the body weight of the subjects was 50 - 86 kg. All the study subjects signed an informed consent, and they were given information about tacrine and the protocol of the experiments. The studies

were approved by the ethical committee of the Helsinki University Hospital and Finland's National Agency for Medicines. A physician supervised the experiments and followed the well-being of the volunteers. The blood samples were taken by a registered nurse.

4.3 Methods (I-IV)

4.3.1 Preparation of the drug containing ion-exchange fiber discs/bundles (I-IV)

To study drug binding capacity and drug release, circular discs (diameter 15 mm) were cut from the cation- and anion-exchange fibers (**I**, **II**). The weight of the discs was 40-100 mg depending on the fiber. Thickness of the Smopex[®]-107 fiber was about 3 mm, Smopex[®]-102 fiber about 6 mm, and Smopex[®]-101 fiber was like a cotton clothing (**II**, **III**). In the study with levodopa and metaraminol (**IV**), the Smopex[®]-101, -102, -103 and -105 were used as staple fibers. Polyethylene backbone of the fiber was grafted by radiation with polyacrylic acid (Smopex[®]-102), polysulphonic acid (Smopex[®]-101) or both the polyacrylic acid and polysulphonic acid (Smopex[®]-107), trimethylamine (Smopex[®]-103), pyridine (Smopex[®]-105) or by polyamine (Smopex[®]-108). Thus, the cation-exchange groups were carboxylic or sulphonic acids and the anion exchange took place by tertiary amines, pyridine and primary amines, respectively. To increase ion-exchange capacity (**I**), the cation-exchange fiber discs were treated with 1 M nitric acid solution until all the sodium was exchanged (3 h). Thereafter, to remove the acid, the fiber discs were washed with purified water until the pH was about 4.5. The ion-exchange discs were immersed overnight in 5 % (m/V = 50 mg/ml) tacrine(-HCl) (5.3 mmol), propranolol(-HCl) (4.2 mmol) or nadolol (4.1 mmol) solution (25 ml). Anion-exchange fiber (Smopex[®]-108) was treated with 1 M NaOH solution and washed with purified water until the pH was 8.5. To load the drug to the discs, 5 % (m/V) sodium salicylate (7.8 mmol) solution was used (25 ml). To remove the unattached drug, the squeezed discs were then washed repeatedly with a total of 150 ml of purified water and dried at room temperature (**I**).

In the drug release studies (**II**, **IV**) the cation-exchange fiber discs/bundles were treated with 0.1 M NaCl solution or 0.1 M NaCl/0.1 M NaOH (1:1) solution and the anion-exchange fiber bundles with 0.1 M HCl solution for about half an hour. Thereafter, the fiber discs were washed with purified water. The fiber discs/bundles were immersed in 1 % (m/V) tacrine(-HCl), propranolol(-HCl), nadolol (**II**) and in 0.5 % metaraminol(bitartrate) or 0.1 % levodopa (**IV**) solutions (100 ml) three times consecutively. At the first and second times the discs were kept in the solution for three hours and for the third time overnight (about 12 h). After each immersion, the discs were washed with purified water. The fiber bundles were immersed in a 0.1 % levodopa solution at pH 2.0, 7.4 or 10.0 or in a 0.5 % metaraminol(bitartrate) solution at pH 2.0 or 7.4, depending on the experiment (**IV**). The amount of adsorbed drug in the fiber discs was determined by HPLC from the combined washing solutions (**I-IV**).

4.3.2 Drug release studies (I, II, IV)

In the preliminary studies (**I**), drug release from the cation-exchange fiber discs was tested in Franz diffusion cells (Crown Glass Co., Somerville, NJ) at 25°C. The fiber discs were placed in the diffusion cells so that one side of the ion-exchange fiber was exposed to the dissolution medium (3.0 ml of HEPES-buffered saline, pH 7.4). The surface area of the fiber discs exposed to the buffer was 0.64 cm². Samples were collected at fixed intervals for 24 h (1, 5, 10, 15, 20, 25, 30 and 45 min, 1, 2, 4, 6, 8, 12 and 24 h) and drug concentrations in the samples were determined by HPLC.

In the more thorough experiments (**II**, **IV**), drug release from the cation-exchange fibers Smopex[®]-101 and -102 (**II**, **IV**) and anion-exchange fibers Smopex[®]-103 and -105 (**IV**) were tested *in vitro* in glass dish (with bottle top) at a temperature of 25°C. Drug containing fiber discs were separately placed in NaCl solutions (0.0015 M, 0.015 M, 0.15 M and 1.5 M). Each NaCl solution contained an equimolar concentration of the salt as the concentration of the drug was in the fiber. To measure drug release from the fiber, the NaCl solutions were changed five times during a week (24, 48, 72, 96 and 168 h) (**II**) or two days (1, 2, 4, 6, 10, 24, 48 h) (**IV**). Effects of pH and ion-exchange groups on the

drug release were studied with a zwitterionic, easily oxidized levodopa, and with a cationic (presumably more stable) metaraminol (IV). In the studies with levodopa and metaraminol, the volume of the NaCl solution was 10 ml, regardless of the concentration of drug in the fiber (IV). The fiber discs were washed with mQ-water (10 ml) and squeezed, the washing solutions were collected, and the released drug concentrations in these solutions were determined by HPLC. In addition to drug release tests in NaCl solutions, tacrine release from the Smopex[®]-101, -102 and -107 fibers was tested in the presence of 10%/90%, 50%/50% and 90%/10% CaCl₂/NaCl solutions (II). The total NaCl+CaCl₂ concentration was 0.015 M in each case. The release of levodopa from the Smopex[®]-102 fiber was also tested in a 100 % CaCl₂ solution (0.15 M) at pH-values 2.0 and 7.4 (IV). In these experiments, the fibers were activated with 0.1 M NaCl/0.1 M NaOH solution.

Drug release with iontophoretic current from the cation-exchange fiber discs was tested *in vitro* in Side-by-side[®]-diffusion cells (Crown Glass Co. Inc., Somerville, NJ) (I). In these experiments the samples (50 µl) were collected also from the donor compartment at 1, 2, 4, 6, 8, 12 (current off), and 24 h during the permeation experiments *in vitro*.

4.3.3 Source and preparation of skin (I, IV)

The membrane tissue was human cadaver skin from Kuopio University Hospital (I) and Helsinki University Hospital (IV). Each skin sample was heated two minutes in 60°C water (Gummer, 1988), and the epidermis was separated using surgeon's knife. The samples were dried at room temperature and cut into 3 cm x 3 cm pieces, which were kept in a freezer until used.

4.3.4 Transdermal permeation experiments *in vitro* (I, III, IV)

Side-by-side[®]-diffusion cells (I, IV): *In vitro* permeation studies were performed in Side-by-side[®]-diffusion cells (Crown Glass Co. Inc., Somerville, NJ (I), Laborexin, Helsinki, Finland (IV)) at a room temperature. Permeation studies were performed with

tacrine, propranolol, nadolol, sodium salicylate (**I**), levodopa and metaraminol (**IV**). The human *stratum corneum* was clamped between the two identical halves of the diffusion cell. The area of exposed skin was 0.64 cm² (**I**) or 0.785 cm² (**IV**). HEPES-buffered, physiological NaCl (pH 7.4 (**I, IV**) and 4.0 (**IV**)) was placed in the receiver compartments of the diffusion cells. Drug containing ion-exchange fibers or the drug solution (tacrine, propranolol, nadolol or sodium salicylate 150 mg/3 ml (**I**); metaraminol 8.0 mg/3 ml or levodopa 5.0 mg/3 ml (**IV**)) were placed in the donor compartment in the same buffer. Positively charged drugs were iontophoresed from the anodic compartment; the negatively charged drug was delivered from the cathode. Samples (250 µl) were collected from the receiver compartment and replaced by fresh buffer at 1, 2, 4, 6, 8, 12 (current off), and 24 h (**I**) and at 0.5, 1, 2, 3, 4, 5 and 6 h (**IV**).

Franz-type diffusion cells (III): Permeation studies of the tacrine formulations were performed across the excised human *epidermis* (Helsinki University Hospital) *in vitro* in Franz-type diffusion cells (Laborex Oy, Helsinki, Finland) at a room temperature. The area of the exposed skin was 2.41 cm². The test formulations were placed in the donor compartment, and HEPES-buffered physiological NaCl was placed in the receiver compartment. Samples (200 µl) were collected from the receiver compartment and replaced by fresh buffer at 30, 60, 90, 120, 150, 180 (current off), and 240 min. The current source used was Phoresor[®] II Auto (Iomed Inc., Salt Lake City, USA), the same as was used in the *in vivo* experiments (see section 4.3.5).

Iontophoretic apparatus (I, IV): Silver-silver chloride electrodes were used in all the iontophoretic experiments (Green et al., 1991). Ag/AgCl-electrodes were preferred to platinum electrodes because of avoiding changes in pH due to electrolysis of water. During the experiments the electrodes were separated from the donor and receptor chambers by salt bridges, which consisted of 1 M NaCl gelled with 3 % agarose inside plastic tubing (diameter 4 mm, length ca. 15 cm). Salt bridges prevented direct contact and possible reactions of the drugs with the Ag/AgCl-electrodes. The electrolyte that surrounded the electrodes was HEPES (25 mM) buffered saline (0.15 M) at pH 7.4. A constant current (6181C DC Current Source, Hewlett Packard, USA (**I**), Ministat current

source, Sycopel Scientific Ltd., Boldon, England (**IV**)) of 0.1 mA/cm² (**I**), 0.25 mA/cm² (**I**), and 0.5 mA/cm² (**I**, **IV**) was applied for 6 h (**IV**) or 12 h (**I**), and for the next 12 h the passive flux was monitored (**I**). The current/voltage was monitored throughout each experiment (F2378A multimeter, Hewlett Packard, USA).

Data analysis (I, III, IV): The amount of drug that had permeated through the human *stratum corneum* during a given time interval was calculated from the concentrations measured in the receptor compartment, which were corrected for sampling dilution and volume. Steady-state fluxes, J_{ss} (μg/h per cm² or nmol/h per cm²), were calculated by linear regression of the linear portion of permeation curves. All the experiments were performed at least three times.

To determine whether a clinically relevant steady-state concentration of a drug in the plasma (C_{ss} , ng/ml) during transdermal drug delivery could be achieved, C_{ss} was calculated using the equation

$$C_{ss} = A J / CL \quad (\text{Equation 4}),$$

where A is the surface area for drug absorption, J is the steady-state flux (μg/h per cm²), and CL (l/h) is the pharmacokinetic clearance of the drug from the body (Notari, 1987).

4.3.5 Transdermal permeation experiments *in vivo* (**III**)

Tacrine permeation (III): The *in vivo* experiments were performed using a battery operated (9 V) constant current source Phoresor[®] II Auto (Iomed Inc., Salt Lake City, USA). In the first experiment (Test I) the electrodes were commercial Iogel[®]-electrodes (Salt Lake City, USA). The system was the same as used by Ashburn et al. (1995) to deliver fentanyl citrate across the skin. The structure of a custom-built transdermal device used in the second test (Test II), is shown in Fig. 4. Silver-silver chloride electrodes were used for current delivery. Next to the anode and cathode electrodes was 1.5 M NaCl solution to maintain proper current delivery. Ion-selective Nafion[®]-membrane prevents

the drug molecules from getting into the opposite direction. The heart of this device was ion-exchange fiber (Smopex[®]-102), wherein the model drug, tacrine, was attached. Physiologic NaCl solution in the fiber compartment ensured a predetermined drug release for tacrine permeation. Positively charged drug is released by the Na⁺-ions. The area of these devices on the skin was 10 cm². The total amount of free tacrine in each experiment was adjusted to 64 mg. The porous membrane was against the skin. A constant current of 0.4 mA/cm² was applied for 3 h on the ventral forearm of the volunteers. For the next 1 h passive tacrine flux was measured. The current/voltage was monitored throughout the experiments by a voltage/current meter (RTO3800G multimeter). To prevent painful sensations on the skin, the current was gradually increased from 0.1 to 0.4 mA/cm² during the first five minutes of the Tests I and II. The position of the electrodes was changed three times during the 3-hour experiment.

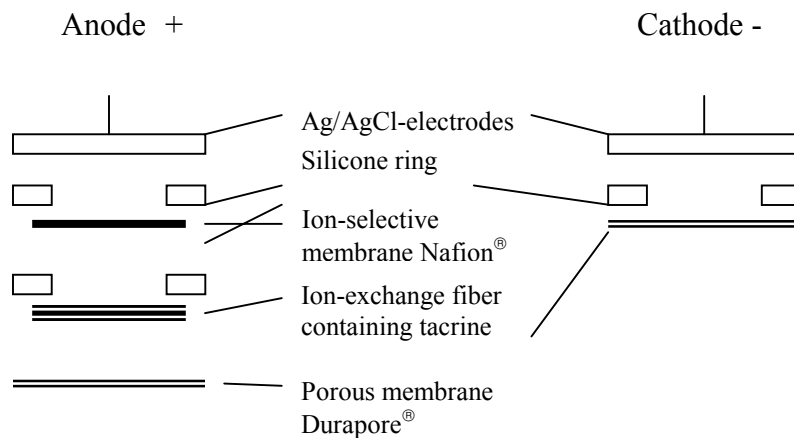

Figure 4. The structure of the ion-exchange fiber device in the Test II (III).

Safety evaluation (III): The study subjects did not have a disease of the liver or a skin damage at the sites of transdermal application. The model drug, tacrine, is known to cause hepatic side-effects (Alhainen, 1992; Sathyan et al., 1995). Therefore, alanine aminotransferase (ALT) level of the test subjects was determined before and after the experiments. The value had to be ≤ 50 U/l before the subject was accepted for the tests. Adverse effects of tacrine and iontophoresis on the skin were evaluated visually (erythema, swelling/drying), and by asking the volunteers about their

sensations/symptoms during the tests and up to one week after the tests were finished. Also, a physician supervised the experiments and followed the well-being of the volunteers. In addition to Tests I and II, the possibly irritating effect of tacrine (no current) and iontophoresis (0.1 – 0.4 mA/cm²; no tacrine), on the skin of the volunteers was measured.

4.3.6 Analysis of the drugs (I-IV)

HPLC assays (I-IV): Drug concentrations in all the experiments were analyzed by high performance liquid chromatography (HPLC) (Beckman Instruments Inc., San Ramon, CA, USA (I-III), Thermo Separation Products Inc., San Jose, CA, USA (IV)). HPLC-methods for the model drugs are shown in Table 4.

Assay of serum tacrine concentrations (III): Venous blood samples of 10 ml were withdrawn from the volunteers at 30, 60, 90, 120, 150, 180 and 240 min. The withdrawn blood samples were centrifugated 30 min after the sampling, and plasma was separated. The plasma samples were kept in a freezer until analysis. Tacrine was extracted from the plasma in an extracting tube Chrompack Varian[®] (Bond Elut-C₁₈, Varian Inc., Harbor City, CA, USA), (McDowall, 1989). The extracting tube was regenerated by 1 ml of MeOH and 1 ml of purified water. One ml of the plasma sample was placed in the tube, whereafter the tube was washed with 1.5 ml of purified water. Tacrine was eluted using a 6 ml solution of 22 % acetonitrile, 1 % triethylamine, and 77 % deionized water at pH 6.5. The extracted tacrine solution was evaporated with air and dissolved in 200 µl of HEPES-buffered saline at pH 7.4. The linear concentration range for tacrine extraction was 5 - 250 ng/ml with a precision of ± 4.2 % (SD).

Liquid Scintillation Counting (LSC) (IV): For the analysis of ¹⁴C-mannitol, 50 µl of the sample was mixed with 150 µl of deionized water and 4.5 ml of scintillation liquid (OptiPhase “HiSafe” 2, Wallac, Fisher Chemicals, Loughborough Leics, England). The ¹⁴C-activities were measured by liquid scintillation counting using WinSpectral 1414 Liquid Scintillation Counter (LSC) (Wallac, Turku, Finland).

Table 4. HPLC methods for the drugs used (**I-IV**). In each case the flow rate was 1.0 ml/min. The column was Supelcosil LC-18-DB (150 mm x 4.6 mm; 5 µm; Supelco Inc., PA, USA) in the cases of tacrine, propranolol, nadolol, and sodium salicylate (**I, II, III**) and Luna C₁₈ (150 x 4.6 mm; 5 µm; Phenomex, CA, USA) with levodopa and metaraminol (**IV**).

| drug | Buffer (fraction) | pH | organic phase (fraction) | wavelength (λ) | modified from reference |
|-------------------|---|-----|--------------------------|----------------|-------------------------|
| tacrine | 1 % TEA in mQ-water (0.78) | 6.5 | ACN (0.22) | 240 | Forsyth et al., 1988 |
| propranolol | 2 % TEA in acetate buffer (0.65) | 4.0 | ACN (0.35) | 289 | Sutinen et al., 1990 |
| nadolol | 1 % HSA in acetate buffer (0.75) | 4.0 | ACN (0.25) | 223 | A new method |
| sodium salicylate | 50 mM potassium phosphate buffer (0.60) | 7.0 | MeOH (0.40) | 298 | Hirvonen et al., 1993 |
| levodopa | 25 mM ammonium acetate in mQ-water (0.99) | 4.1 | MeOH (0.01) | 282 | Kafil and Dhingra, 1994 |
| metaraminol | 25 mM ammonium acetate in mQ-water (0.95) | 4.1 | MeOH (0.05) | 272 | Kafil and Dhingra, 1994 |

4.3.7 Statistical analyses (III)

Possible statistical differences between the tacrine plasma levels in the *in vivo* studies (Tests I and II) were determined using a paired t-test. The standard deviations (a measure of biological variation) were proportioned to the average values, and tested for a possible difference by the paired t-test as well. Statistically significant level was set as $p < 0.05$.

5 RESULTS AND DISCUSSION

5.1 Drug binding/adsorption into the ion-exchange fibers (I, II, IV)

Properties of the ion-exchange fiber and drug (II): Both strong (-SO₃H) and weak (-COOH) ion-exchange groups were studied. Table 5 shows the drug content of ion-exchange fibers containing sulphonic groups (Smopex[®]-101 and -101*), carboxylic groups (Smopex[®]-102 and -102*) and their combination (Smopex[®]-107). From the columns corresponding to Smopex[®]-101, -101* and -102*, it can be observed that the drug content in the fiber increases with the increasing drug lipophilicity, but the results of -102 and -107 fibers are not unambiguous.

Table 5. Drug content (mmol/g) in the Smopex[®] -101, -102 and -107 ion-exchange fiber discs. Fibers were activated with 0.1 M NaCl solution (101, 102, 107) or 0.1 M/0.1 M NaCl/NaOH solution (101*, 102*).

| Drug | Log P _{oct} ¹ | Drug content (mmol/g) | | | | |
|-------------|-----------------------------------|-----------------------|------|------|------|------|
| | | 101 | 101* | 102 | 102* | 107 |
| Tacrine | 3.3 | 4.43 | | 1.43 | 8.30 | 0.98 |
| Propranolol | 3.2 | 3.09 | | 2.94 | 8.33 | 2.69 |
| Nadolol | 0.9 | 1.88 | | 2.28 | 4.54 | 0.98 |
| Metaraminol | -0.27 | | 0.83 | | 0.76 | |
| Levodopa | -2.9 | | 0.10 | | 0.50 | |

¹Drayton, 1990

The differences shown in Table 5 for a given drug in different fibers is a clear manifestation of the fact that the distribution equilibrium of the drug is affected by drug-fiber interactions, which are specific to the ion-exchange group and the fiber nature. The strength of these interactions is quantified by the chemical partition coefficient (II).

Strong electrostatic bonds have a chemical nature and only ionized molecules are capable to be bound into this layer, where the concentration of binding molecules is usually very high (Conaghey et al., 1998b; Marchal-Heussler et al., 2000). Levodopa was shown to be bound into the ion-exchangers, although both the drug and fiber were partially charged by the same sign (IV, Table 3). Both the ionized and non-ionized drug molecules may also bind via loose hydrophobic interactions. These mechanisms could explain the incorporation of drugs into the ion-exchange fibers of similar charge.

Activation of the ion-exchange fiber (II, IV): The effect of activation on the drug binding capacity of the ion-exchange fibers is clearly shown in Table 5. The binding capacity of the -102 fiber that was activated only with 0.1 M NaCl solution was clearly lower than the capacity of the fiber -102* that was activated also with NaOH. In the basic solution of NaOH, hydrogen ions are exchanged with sodium ions more easily than in the NaCl solution alone. The better adsorption was more obvious with the more lipophilic drugs. Tacrine (the most lipophilic drug) was bound into the -COOH groups of the ion-exchange fiber ca. six times better when the fiber was activated with NaOH. The maximal binding capacity of this Smopex[®]-102 ion-exchange fiber is ca. 8.0 mmol/g (all the grafted ion-exchange groups occupied). Thus, when the fibers were activated with NaOH, all the binding places were filled with drug in the case of the more lipophilic drugs. In the case of the more hydrophilic nadolol, half of the binding groups were occupied, and with the very hydrophilic metaraminol and levodopa ($\log P_{\text{oct}}$ are -0.27 and -2.9, respectively), the drug content was less than 1 mmol/g. There were also smaller amount of levodopa and metaraminol than other drugs in the adsorption medium. Due to the low solubility of levodopa and metaraminol, more concentrated drug solution could not been used.

Drug concentration in the external solution (I, II, IV): Drug incorporation into the fiber was accomplished in three steps. At the first two times the drug incorporation was significantly greater than at the third time. At the beginning, the concentration difference between the drug in the solution and in the fiber was larger than during the last immersion, which probably explains the results observed. Thus, at the first step all the

binding places (ion-exchange groups) are free. Lin and Hsieh (1996) have observed the same. When the total number of drug ions in the solution, amount of fiber, temperature, and total absorption time were kept the same, higher drug adsorption was observed in the case of the greater concentration gradient of the drug.

pH of the external solution (IV): According to Henderson-Hasselbalch equation (Martin, 1993), one may calculate the ionized % of the ion-exchange groups of the fiber(s) and of the drug at the pH-values studied. In Smopex[®]-105 the ionizable group is pyridine, a weak base ($pK_a \approx 5$), which is ionized mainly at acidic pH-values (IV: Table 1). The trimethylammonium group in the Smopex[®]-103 is a strong base ($pK_a > 13$), which is ionized at all the pH-values studied. Only a small fraction of the weakly acidic –COOH –groups ($pK_a \approx 4$) of Smopex[®]-102 are ionized at pH 2.0. In contrast, the strong ion-exchanger Smopex[®]-101 (–SO₃H –groups, $pK_a < 1$) was totally in an ionized state at all the pH-values studied. The amount of levodopa adsorption into all the ion-exchange fibers was clearly reduced at pH 7.4 (as compared to pH 2.0 and 10.0), (IV: Table 2). Theoretically, levodopa possesses both a positive and a negative charge at pH 3-9 (Merck Index, 1996). When levodopa was changed into its HCl-salt (by dissolving it into a 0.1 M HCl-solution, IV: Fig. 3), the adsorption of levodopa into the Smopex[®]-101 fiber was increased four-fold. Thus, although levodopa exists as a zwitterion at pH 7.4, it forms an intrinsic molecular salt with a net charge of zero.

Summary of the properties of drug, ion-exchange fiber and external solution, which affect the binding of drugs into the ion-exchange fibers, is presented in Table 6.

Table 6. The properties of drug, ion-exchange fiber and external solutions, which affect the binding of a drug into the ion-exchange fibers.

| Property | | Effect |
|---|----------|---|
| drug lipophilicity ↑ | => | drug content ↑ (or no clear effect) |
| ion-exchange groups | => => | specific interactions drug content ↑ or ↓ |
| activation of fiber | => => | drug binding capacity ↑ drug content ↑ |
| drug concentration in the external solution ↑ | => => | concentration gradient ↑ drug content ↑ |
| pH of external solution | => => | dependent on the pKa of drug drug content ↑ or ↓ |

5.2 Control of drug release from the ion-exchange fibers (I, II, IV)

During their preparation, the cation-exchange fiber discs with the ion-exchange groups in hydrogen form were immersed in a solution of the cationic drug and chloride ions. The fiber tends to equilibrate with this bathing solution and exchange the hydrogen ions with the cationic drug, that compensate the negative fixed charge groups within the fiber. If the concentration of the cationic drug in the solution is sufficient and if enough time is allowed for this ion-exchange process, the fiber turns completely into drug form. If not, which is usually the case, the fiber contains both the cationic drug and hydrogen ions. Moreover, chloride ions are always present in the fiber phase in a concentration such that the local electroneutrality condition is satisfied (Donnan exclusion) (Helfferich, 1995).

Properties of the drug (I, II): The fiber discs containing cationic drugs were placed in the Franz cell and the passive drug release into HEPES-buffered physiological saline was

followed **(I)**. The release rate observed was larger for nadolol (hydrophilic) than for tacrine and propranolol (both lipophilic), which shows the dependence of the release rate on the lipophilicity of the drug (**I**: Fig. 1).

In publication **II** the drug release kinetics were studied in a more detailed way. The more lipophilic drugs tacrine and propranolol were attached more strongly to the strong ion-exchange groups (Smopex[®]-101, -SO₃H groups), and were released more easily from the fibers containing weak ion-exchange groups (-COOH) (**II**, Fig. 1). Hydrophilic nadolol was released most rapidly from the Smopex[®]-101 fiber. The release of nadolol from Smopex[®]-101 was over ten times higher than that of tacrine from this fiber, while it was only about two times higher in the case of Smopex[®]-102 fiber. This indicates that the specific interactions of the lipophilic drugs with the sulphonic acid fiber are stronger than with the carboxylic acid fiber, while the opposite is true for the interaction of nadolol with these fibers (**II**). Other researchers have found the same effect, *e.g.*, Sprockel and Price (1989) observed that chlorpheniramine ($\log P_{\text{oct}}$ 3.39 (Drayton, 1990)) was released more quickly from a carboxylic acid resin than from a sulphonic acid resin.

Of course, the ion-exchange fiber and the drug in question have to be suitable to each others. *E.g.*, strong ion-exchangers could cause hydrolysis of labile drugs, because they are effective acid-base catalysts (Anand et al., 2001).

Drug content in the fiber (II): Activation of fibers with NaOH increased drug binding into the ion-exchange groups, but the fraction of the drug content that was released in every case remained about same (**II**). Tacrine release from the Smopex[®]-102 fiber in the 0.015 M NaCl solution in one week was 9.4 ± 2.1 % when the tacrine content in the fiber was 1.43 mmol/g, and 8.7 ± 0.85 % with the tacrine content of 8.30 mmol/g. Correspondingly, with propranolol the release was 10.6 ± 0.29 % at 2.94 mmol/g drug content and 12.8 ± 0.27 % when the drug content was 8.33 mmol/g. Thus, although the drug content in the fibers increased and the amount of drug release increased, the relative fraction (%) of the drug release was constant. Conaghey et al. (1998b) have observed the

same influence with ion-exchange resins, a constant fraction of drug was released from the resin although the total drug content in the resin was increased.

Salt concentration (II, IV): The drug can not be released from the ion-exchanger in water, since there are no counter ions in the medium to replace drug ions from the ion-exchanger. Therefore, counter ions are always needed in the dissolution medium (Sriwongjanya and Bodmeier, 1998). The effect of the extracting salt concentration was similar for all the drugs. In general, drug release from the ion-exchange fibers was faster at lower concentrations of NaCl (**II**: Fig. 1). The volume of the extracting salt solution in these drug release experiments with 1.5 mM NaCl was 1000 times larger than in the experiments with 1.5 M NaCl, and this volume difference had a clear effect on the drug release. The change in electrolyte concentration has two competing effects on the drug release. Firstly, increasing electrolyte concentration decreases the Donnan potential and, hence, the electrostatic affinity between the drug and the fiber, thus tending to increase drug release. Secondly, a large electrolyte concentration implies a small volume of the external solution and then a very small amount of drug release is needed to reach the equilibrium drug concentration in the external solution. This latter volume effect was obviously dominant in this study (**II**).

The experimental setup of the study above was different from the most studies in the literature. Typically the same external solution volume has been used for the different electrolyte concentrations. With metaraminol tests, the volume of external solution was kept the same and the NaCl concentration was varied (**IV**). The higher the NaCl-concentration, the higher the drug release was observed (**IV**: Fig. 4). The work of Conaghey et al. (1998a) showed that nicotine was released more slowly from ion-exchange resin at lower ionic strengths of the release medium. The same effect has also been observed in other studies of ion-exchange resins (Irwin et al., 1987). Bodmeier et al. (1996) observed that the drug release rate from the resins initially increased with the increasing buffer strength and then decreased at even higher buffer strengths. The structure of ion-exchange fibers is arranged like a cloth (Fig. 2), whereas ion-exchange resins have a cross-linked hydrocarbon network with attached ionizable groups (Florence

and Attwood, 1998). Åkerman et al. (1999) have studied drug release from poly(acrylic acid) grafted poly(vinylidene fluoride) membranes at different ionic strengths. They observed that the release rate of propranolol decreased significantly with the increasing ionic strength of the dissolution medium, probably due to a cation-exchange process and swelling behaviour of grafted poly(acrylic acid) chains. A corresponding trend was also observed with other small molecules. Those results are similar to the present studies with the ion-exchange fibers (II).

pH (IV): The pH of the external solution had a clear effect on the release rate of drugs depending on the pKa of drug and ion-exchange group of the fiber. When the ion-exchange group and levodopa/metaraminol possessed the same charge, there were only loose hydrophobic interactions between the fiber and drug. From these loose interactions the drug release was clearly faster than from the ionic interactions. Practically all the drug was released at the initial stage (within 1 hour).

Salt choice (II, IV): Since tacrine and levodopa were very strongly attached to the fibers, the release of tacrine and levodopa was studied with solutions containing also CaCl₂ at a fixed total concentration (II, IV). Even 10 % of CaCl₂ had a profound effect on the drug release, virtually all tacrine was released in the third equilibrium stage (72 h) from Smopex[®]-102 fiber and Smopex[®]-107 fiber (II: Fig. 2). Thus, the release was increased ca. 3-4 times with CaCl₂ as compared to NaCl-solution alone. The release of levodopa from the Smopex[®]-102 ion-exchange fiber was very small (< 1 %) at pH 7.4 (NaCl solutions). In 0.15 M CaCl₂-solution, 44 % of levodopa was released from the Smopex[®]-102 fiber. The interaction of calcium ions with the ion-exchange groups of the fiber was clearly stronger than the interaction of sodium ions. Calcium ions are known to bind strongly to carboxylic groups, but not that strongly to sulphonic groups (Charman et al., 1991; Sørensen and Riviera, 1999). The reason for the improved binding affinity of calcium to ion-exchange groups over the sodium ions is caused by the +2 charge of calcium. Cation-exchange tends to have affinity in the decreasing order for calcium, potassium, sodium, ammonium and hydrogen ions (Florence and Attwood, 1998). Table

7 presents the summary of properties, which affect the drug release kinetics from the ion-exchange fibers.

Table 7. The properties of drug, ion-exchange fiber and external solution, which affect the release rate of a drug from the ion-exchange fibers.

| Property | Effect |
|--------------------------------------|---------------------------------------|
| drug lipophilicity ↑ | => release rate ↓ |
| drug content in the fiber ↑ or ↓ | => relative release rate (%) the same |
| ionic strength ↑ | => release rate ↑ |
| ionic strength ↑ + volume ↓ | => release rate ↓ |
| volume of external solution ↑ | => release rate ↑ |
| pH ↑ or ↓ | => release rate ↑ or ↓ |
| salt choice => specific interactions | => release rate ↑ or ↓ |

5.3 Drug stability (IV)

The structure of levodopa is similar to a hydroquinone structure (double-OH-substituted aromatic ring) (IV: Fig. 1a). Hydroquinones can be oxidized to quinones, which involves a two-one electron transfer step (Hovorka and Schöneich, 2001). The oxidation process proceeds with very mild oxidizing agents, such as Ag^+ or Fe^{3+} present, *e.g.*, in moisture or water. The oxidation of levodopa can be observed also visually, because the hydroquinones are colourless and the quinones are coloured (Fessenden and Fessenden, 1990). The oxidation of levodopa (in solution) was fast present especially in basic solutions (IV: Fig. 3). Already at one hour time-point, the initially clear 1.0 mg/ml solution of levodopa had turned into a dark colour, and significant part of levodopa was

oxidized at basic pH-values. When levodopa is oxidized, the hydrogen atoms come off and, therefore, in an acidic environment the oxidation of levodopa is hindered.

In the adsorption, release and permeation studies with the ion-exchange fibers, the concentration of levodopa remained unchanged at least for 48 hours at pH-values of 2.0, 4.0 and 7.4. Drug concentration was the original $\pm 5\%$ in all the cases. Permeation of levodopa from the ion-exchange fiber and solution formulation across the skin was studied at pH 7.4 (IV). Levodopa was oxidized significantly during the first 6-8 hours in the solution formulation, whereas in the ion-exchange fiber formulation levodopa was not oxidized during the 24-hour experiment. Thus, the ion-exchange fibers may provide a good choice in improving the stability of drugs during storage in water. The drug adsorbed into an ion-exchange material may be stored in wet/dry conditions, and the extracting salt may be introduced only immediately prior to the application of the medication into a patient. An additional advantage is the buffer-like behavior of the ion-exchange material (Helfferich, 1995), that holds the pH of the release medium constant.

5.4 Drug permeation studies *in vitro* (I, III, IV)

5.4.1 Drug permeation from solution formulations (I, IV)

Transdermal permeation of the model drugs across the human skin at pH 7.4 was studied both under passive and iontophoretic conditions ($I = 0.5 \text{ mA/cm}^2$). The lag-time for permeation was about 24 h in the case of passive flux and 0.5 h in the case of iontophoretic flux (I). Since all the drugs (Table 8) were delivered from a 5 % solution, the differences observed in the passive flux values were obviously related to the nature of the drug. The hydrophilic drug nadolol exhibited the lowest passive flux, thus showing that it hardly enters the skin. The lipophilic drugs (tacrine, propranolol and salicylate) permeated the skin at a much faster rate than nadolol, but the differences observed do not correlate well with their octanol/water partition coefficients (see Tables 3 and 8).

Table 8. Passive and iontophoretic fluxes ($\mu\text{g/h per cm}^2$) across human skin *in vitro* from a 5 % (m/V) solution. Direct current iontophoresis (0.5 mA/cm^2) was on for 12 h. Mean \pm standard deviation, N = 4-7.

| Drug | passive flux | iontophoretic flux | enhancement factor |
|-------------------|---------------------|---------------------------|---------------------------|
| Tacrine | 3.0 ± 0.7 | 220 ± 50 | 70 |
| Propranolol | 0.26 ± 0.07 | 43 ± 7 | 170 |
| Nadolol | 0.04 ± 0.05 | 49 ± 7 | 1200 |
| Sodium salicylate | 0.34 ± 0.07 | 45 ± 6 | 130 |

Clear increase of transdermal permeation during iontophoresis was observed for all the drugs (Table 8). The enhancement factor, E, [$E = J_{\text{iontophoresis}}/J_{\text{passive}}$ (Srinivasan and Higuchi, 1990, Kontturi and Murtomäki, 1996)] varied from 70 to 1200. The largest enhancement was found for the most hydrophilic drug, nadolol, which has been reported also earlier (Hirvonen and Guy, 1997). The lowest enhancement factor corresponded to tacrine, which exhibited the largest passive flux.

Permeation of levodopa and metaraminol across the human skin was also studied *in vitro* (IV). A small increase in transdermal levodopa permeation by iontophoresis was observed ($E = 3$), although the net charge of levodopa was zero and the electroosmotic solvent flow was about zero at the pH 4.0 of the study. Iontophoresis, thus, increases the permeability of skin (Sims et al., 1991). Using iontophoresis, the positively charged metaraminol permeated across the skin significantly more than the zwitterionic levodopa (IV, Figs. 5a and 5b), largely, obviously, due to the electrorepulsion. Enhancement factor of metaraminol permeation from the solution was 932, close to the E-value of nadolol.

The permeation rate of tacrine was studied as a function of the iontophoretic current density (I), from 0 (passive) to 0.5 mA/cm^2 , which is considered the upper limit for safe iontophoresis (Burnette, 1988). The iontophoretic permeation rate remained constant

until the current was switched off, and its value was directly related to the iontophoretic current density I (I: Fig. 3). This is in accordance with several literature reports (Behl et al., 1989; Srinivasan et al., 1989; Delgado-Charro et al., 1995; Conaghey et al., 1998b). After current termination the transdermal permeation rate of tacrine returned rapidly to the passive level, which indicates that iontophoretic flux enhancement does not lead to permanent changes in the skin permeability.

5.4.2 Drug permeation from ion-exchange fibers (I, III, IV)

Figure 5 presents a schematic model of transdermal drug delivery using iontophoresis and cation-exchange fiber.

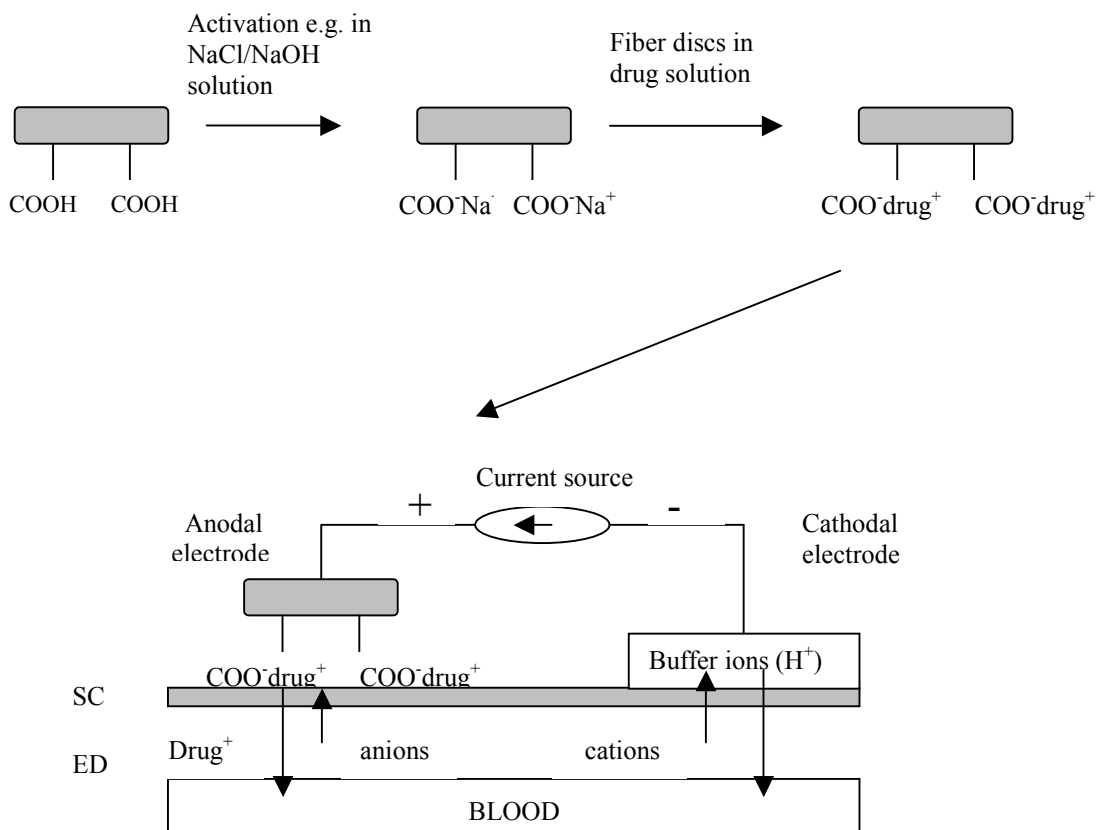

Figure 5. A schematic model of iontophoretic drug delivery by ion-exchange fiber.

If one wants to achieve steady-state flux of drugs across the skin, concentrations of the drug and mobile ions in the bathing solution of the donor compartment need to be constant. Direct current iontophoresis is the way to achieve constant drug flux across the skin. The validity of this assumption was tested by taking samples in both the donor and receiver compartments of the diffusion cell (I). Tacrine concentration in the donor chamber and the flux across the skin during iontophoretic delivery increased for 3-4 hours (Fig. 6). After that, tacrine concentration in the donor chamber and the flux of tacrine across the skin remained constant. This indicates that at steady-state the amount of tacrine released from the fiber equals the permeation of the drug across the skin as long as the current is turned on.

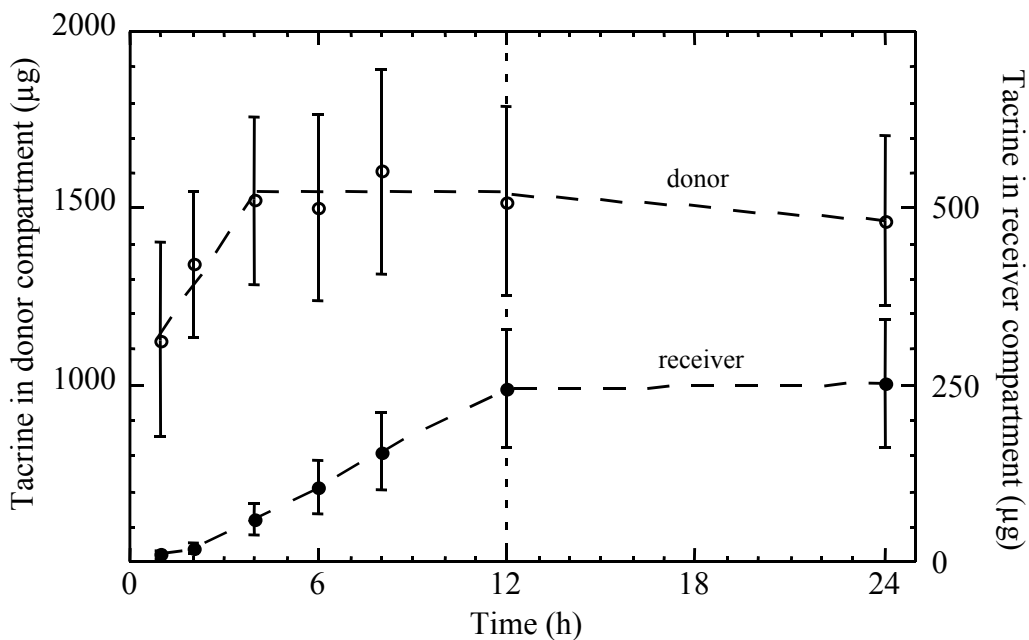

Figure 6. Amount of tacrine in the donor (o) and the receiver (•) compartments during iontophoretic delivery across the human skin from Smopex[®]-102 ion-exchange fiber *in vitro*. Current density was 0.5 mA/cm². The current was on for 12 h, whereafter passive drug permeation was followed up to 24 h. Mean ± SD, N = 6.

The comparison between the passive permeation rates of tacrine across the skin from the 5 % solution and from the ion-exchange fiber is interesting. The passive permeation rate from the solution (drug content 150 mg) was $3.0 \pm 0.7 \mu\text{gh}^{-1}\text{cm}^{-2}$, while that from the ion-exchange fiber (drug content 7.6 mg in fiber) was merely $0.003 \mu\text{gh}^{-1}\text{cm}^{-2}$. The factor 1000 between these two fluxes is explained by drug concentrations. While the 5 % solution contained 150 mg of tacrine, the amount of free tacrine released from the fiber was only about 2 %, which corresponds to 0.15 mg. Thus, the ion-exchange fiber seems to be an excellent drug reservoir that holds almost all the drug tightly in the ion-exchange groups (**I**). Similar behaviour as with tacrine was also observed with the other positively charged model drugs, propranolol, nadolol and metaraminol (**I**, **III**, **IV**). Incorporation of these positively charged molecules into Smopex[®]-102 fiber decreased their permeation across the skin as compared to drug permeation from the corresponding solution formulations.

In order to check the apparent limit of permeation rate, the iontophoretic permeation rate of tacrine across the skin was measured from fiber discs containing different amounts (17.6-104 mg) of drug (**I**). When the amount of tacrine in the fiber was increased, also the flux of tacrine across the skin was increased (**I**: Fig. 5). The increase was not linear in the whole concentration range considered. It has been presumed, that the concentration in the solution is proportional to the concentration within the fiber and, thus, this non-linearity cannot be due to the difference between the drug concentration in the solution and the concentration in the fiber. It is then concluded that the permeation across the skin shows a limiting mechanism at higher concentrations. This finding supports the observations reported of a similar drop off in the delivery rates of nicotine at high concentrations from a hydrogel containing ion-exchange resins across the skin (Conaghey et al., 1998b).

5.5 Drug permeation studies *in vivo* (I, III)

5.5.1 Transdermal delivery of tacrine for systemic use (I)

Based on the physico-chemical properties, the model drug tacrine is a promising candidate for transdermal delivery. During oral administration tacrine undergoes extensive first-pass metabolism and its dose-dependent hepatotoxicity and peripheral cholinergic side effects have been observed (Wagstaff and McTavish, 1994). It has been postulated that maintenance of constant levels of tacrine in the brain may be required to maximize its effects on memory enhancement (Telting-Diaz and Lunte, 1993). Transdermal delivery of tacrine may minimize the above-mentioned problems. Steady-state plasma concentrations after transdermal drug permeation can be calculated using Equation 4. For tacrine the $CL = 150$ l/h and the target plasma level after oral tacrine ingestion is 5–30 ng/ml (Wagstaff and McTavish, 1994). Using these parameters, the passive tacrine permeation from the 5 % solution would result in a plasma level of 0.50 ng/ml and the ion-exchange reservoir will attenuate that level by three orders of magnitude. Thus, a need for permeation enhancement is obvious. Iontophoretic tacrine delivery from the 5 % solution should result in plasma levels of 4.3 ng/ml at 0.1 mA/cm² and 36 ng/ml at 0.5 mA/cm² (I). Iontophoretic delivery from the ion-exchange fiber (0.5 mA/cm²) is expected to yield 7.3 ng/ml of tacrine in plasma at steady state. Overall, therefore, it seemed that clinically relevant amounts of tacrine might be delivered transdermally by the ion-exchange fiber and iontophoresis, presuming that the permeation rates across the skin *in vitro* and *in vivo* are the same (I).

5.5.2 Controlled transdermal delivery of tacrine *in vivo* (III)

Drug delivery (III): The plasma concentrations of tacrine after drug delivery from the Logel[®]-formulation and from the ion-exchange fiber-formulation (Fig. 4) were 21.3 ± 5.9 and 14.9 ± 2.6 ng/ml, respectively (Fig. 7). Plasma concentrations of tacrine were smaller by the use of ion-exchange fiber device than by the gel-electrode ($p < 0.05$). Both the ion-exchange fiber and gel formulations achieved constant plasma concentrations of tacrine within 30 mins. During the one hour passive tacrine permeation (180-240 min), the

plasma concentrations of tacrine decreased only slightly (Fig. 7). This may be due to the formation of tacrine reservoir in the skin during the drug delivery. Tacrine is a rather lipophilic drug with a $\log P_{\text{oct}} = 3.3$, (Drayton, 1990), which may well be bound into the lipophilic skin structures (*stratum corneum*), and to be released slowly from there into the systemic circulation.

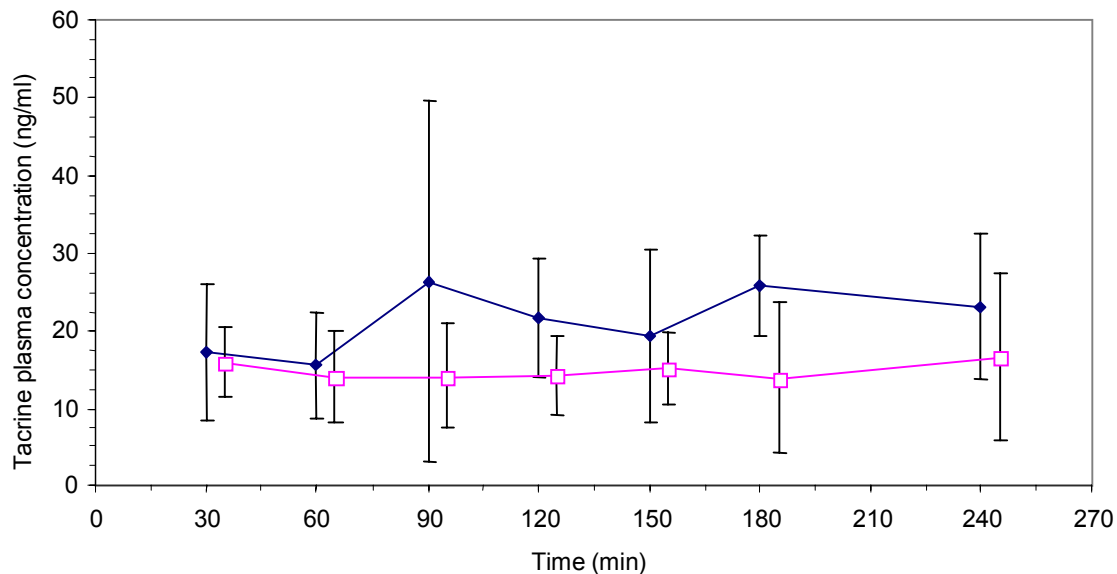

Figure 7. Plasma concentrations of tacrine as a function of time. Test I, Iogel[®]-electrodes (N = 10) (◆) and Test II, ion-exchange fiber device (N = 9) (□). Average \pm SD. To distinguish the Tests I and II, the curve of the latter has been transferred for 5 min.

In general, the inter- and intrasubject variations are high in human pharmacokinetic studies, and variability is a problem also in both the passive and iontophoretic transdermal drug delivery (Ashburn et al., 1995; van der Geest et al., 1997; Gupta et al., 1998; Rohr et al., 1998). By the use of ion-exchange fiber this variation was attempted to be reduced, but at least in the case of tacrine, this was not achieved (**III**). The standard deviations during the iontophoresis in Test II were slightly smaller than using the gel system (Test I), but the difference was not statistically significant ($p > 0.05$). Subject

variations were, however, quite small in both the gel- and ion-exchange formulations. Even if the absorption kinetics of a drug may be controlled by the use of proper drug delivery system like transdermal patch, the clearance of the drug or the barrier function of the skin of the individual subjects can not be predetermined.

Safety (III): In addition to poor permeability of drugs, adverse skin reactions, mainly skin irritation, limit the number of potential drug candidates for transdermal drug administration (Ledger, 1992). Enhancement of transdermal drug delivery, including the use of iontophoresis, may also lead to irritant reactions in the skin (Ashburn et al., 1995). Table 9 lists the adverse reactions on the skin by the visual observations and by the personal comments of the volunteers during the iontophoretic tacrine delivery Tests I and II (+ control data). One volunteer interrupted the Test II due to painful blood sampling (no relation to skin irritation). Application of tacrine solution (without iontophoresis) on the skin did not result in any visible/sensitization reactions. In contrast, the skin of all the study subjects was clearly erythematous by the iontophoretic current delivery (Table 9). The irritation of the skin was directly related to the iontophoretic current density (0.1-0.4 mA/cm²) and the duration of application. The subjects that had a light skin reported a stronger and longer lasting erythema. It's to be noted, that after hard physical activity the skin of five volunteers was little erythematous even one week after the experiment. Slightly pinching sensation was felt by all the study subjects at the first minutes of current passage at the sites of application and at nearby regions. A sensation was felt every time the current density was increased or the position of the device was changed.

Although tacrine itself did not increase the erythema at the concentration used, drying of the skin was observed on several study subjects (Table 9). Tacrine, an anticholinergic drug, caused also sensations of coldness on the skin and on the fingertips of 50 % of the study subjects. Transdermal delivery of tacrine had no effect on the alanine aminotransferase levels of the volunteers in these short tests. All the ALT-values of the test subjects stayed under the normal range (≤ 50 U/l). Obviously, further trials are needed to determine the possible effects of long-term transdermal delivery of tacrine on

the liver function. Liver toxicity of tacrine is expected to be lower transdermally than by oral administration due to the decreased first-pass metabolism.

Table 9. Adverse side effects following transdermal iontophoresis of tacrine. Number of volunteers in Test I = 10 and II = 9. Control measurements (N = 5) included tacrine in solution (no iontophoresis) or iontophoretic current (no tacrine).

| Adverse effect | Test I | Test II | Tacrine | Iontophoresis |
|-------------------------------------|---------------|----------------|----------------|----------------------|
| Pinching | 10 | 9 | 0 | 5 |
| Erythema | 7 | 7 | 0 | 3 |
| Strong erythema | 3 | 2 | 0 | 2 |
| Drying of the skin | 5 | 5 | 1 | 2 |
| Coldness on the skin and fingertips | 5 | 5 | 0 | 0 |

The observed side effects caused by the iontophoresis in these experiments did not differ significantly from the side effects observed previously (Ashburn et al., 1995; van der Geest et al., 1997; Gupta et al., 1998). Because all the plasma concentrations determined were higher than the smallest therapeutic tacrine concentration, a lower or intermittent current density may be used and still reach clinically relevant medication transdermally. In addition, when the transdermal system is attached into a new site, iontophoresis has to create new "pores" to the *stratum corneum* and this causes temporary lag time and reduction in the drug flux. For this reason, tacrine concentrations would possibly have been even higher, if the system would have stayed at the same location for the whole experiment.

***In vitro/in vivo* correlation of tacrine permeation (III):** Tacrine was delivered from the gel (Test I) and from the ion-exchange fiber (Test II) for 3 h by iontophoresis and for 1 h

passively *in vitro*. At the beginning there was a short lag time (30 min) in the tacrine flux. Thereafter, the flux was constant until the current was turned off. After current termination the *in vitro* transdermal tacrine flux returned rapidly to a passive level. Thus, in contrast to tacrine delivery *in vivo*, the drug flux across the human skin *in vitro* decreased dramatically when the current was turned off. The reason for this may lie in the preferable partitioning of tacrine in the skin structures, which prevents it from entering the hydrophilic receptor chamber (no general circulation to distribute the drug throughout the individual subject). The flux values for the tacrine permeation were 5.61 ± 1.31 $\mu\text{g}/\text{min per cm}^2$ (gel-formulation) and 0.11 ± 0.049 $\mu\text{g}/\text{min per cm}^2$ (ion-exchange-fiber formulation). Based on these flux values, the predicted *in vivo* plasma levels would be 22.4 ± 5.3 ng/ml and 0.43 ± 0.19 ng/ml using the gel and the ion-exchange formulations, respectively. The corresponding *in vivo* data values were 21.3 ± 5.9 ng/ml and 14.9 ± 2.6 ng/ml. The correlation between the *in vitro* and *in vivo* data was very good in the case of gel formulation. However, with the ion-exchange fiber formulation, the *in vitro* data predicts a significantly smaller flux than the actual drug delivery *in vivo* was.

Other research groups have observed variable results on transdermal *in vitro/in vivo* correlation (Franz, 1975; Franz, 1978; Guy et al., 1986; Riviere et al., 1990; Riviere et al., 1991; Green et al., 1992; Phipps and Gyory, 1992; van der Geest et al., 1997; Fang et al., 1999; Magnusson et al., 2000). *E.g.*, Phipps and Gyory (1992) observed that the drug concentration in iontophoretic drug delivery *in vivo* was generally higher than the concentration *in vitro*, while van der Geest et al. (1997) observed contradictory results, *in vitro* permeation of apomorphine was greater than the *in vivo* delivery. The correlation seems to be, therefore, highly dependent on the experimental conditions, the individual skin source, and the drug in question. To find out the reason(s) for the poor correlation between the *in vivo* and *in vitro* studies involving the ion-exchange fiber formulation (Test II), further studies are needed.

6 CONCLUSIONS

This study focused on controlled transdermal drug delivery. Iontophoresis and cation- and anion-exchange fibers were used to control the drug adsorption/release and the kinetics of drug permeation. The main conclusions are:

- 1) Cation- and anion-exchange fibers have been shown to be promising drug reservoir materials for iontophoretic transdermal delivery devices.
- 2) The release rate of drugs from the ion-exchange fibers depends on a specific combination of the drug, fiber, and the concentration and nature of the external electrolyte.
- 3) Ion-exchange fibers are promising materials also for the storage of easily degradable and oxidizable drugs.
- 4) Iontophoresis and ion-exchange fibers provide a potential mean to precisely control the permeation of drugs across the skin (*stratum corneum*).
- 5) Clinically relevant plasma concentrations of tacrine were reached in human volunteers by transdermal iontophoresis (gel-formulation, ion-exchange fiber formulation). Only minor irritation on the skin was observed, which was caused mainly by the iontophoretic current delivery.

7 REFERENCES

- Adams BA and Holmes EL, Absorptive properties of synthetic resins. Part I. J. Soc. Chem. Ind. 54: 1T-6T, 1935
- Alhainen K, Anticholinesterase Drug, Tacrine (THA), in Alzheimer's Disease. Series of reports in the Department of Neurology No. 27, Kuopio University Printing office, 1992
- Anand V, Kandarapu R and Garg S, Ion-exchange resins: carrying drug delivery forward. Drug Disc. Today 6: 905-914, 2001
- Ashburn MA, Streisand J, Zhang J, Love G, Rowin M, Niu S, Kievit K, Kroep JR and Mertens MJ, The iontophoresis of fentanyl citrate in humans. Anaesthesiology 82: 1146-1153, 1995
- Aungst BJ, Blake JA and Hussain MA, Contributions of drug solubilization, partitioning, barrier disruption, and solvent permeation to the enhancement of skin permeation of various compounds with fatty acids and amines. Pharm. Res. 7: 712-718, 1990
- Bach M and Lippold BC, Percutaneous penetration enhancement and its quantification. Eur. J. Pharm. Biopharm. 46: 1-13, 1998
- Barry B, Mode of action penetration enhancers in human skin. J. Control. Rel. 6: 85-97, 1987
- Behl C, Kumar S, Malick S, DelTerzo S, Higuchi W and Nash R, Iontophoretic drug delivery: Effects of physicochemical factors on the skin uptake of nonpeptide drugs. J. Pharm. Sci. 5: 355-360, 1989
- Bellantone NH, Rim S, Francoeur ML and Rasadi B, Enhanced percutaneous absorption via iontophoresis I. Evaluation of an in vitro system and transport of model compounds. Int. J. Pharm. 30: 63-72, 1986
- Benoit E, Prot O, Maincent P and Bessier J, Adsorption of beta-blockers onto polyisobutylcyanoacrylate nanoparticles measured by depletion and dielectric methods. Pharm. Res. 4: 585-588, 1994
- Benz R and Zimmermann V, The resealing process of lipid bilayers after reversible electrical breakdown. Biochim. Biophys. Acta 640: 169-178, 1981
- Berner B and John VA, Pharmacokinetic characterisation of transdermal delivery systems. Clin. Pharmacokinet. 26: 121-134, 1994
- Berti JJ and Lipsky LJ, Transcutaneous drug delivery: A practical review. Mayo Clin. Proc. 70: 581-586, 1995

Bodmeier R, Guo X, Sarabia RE and Skultety PF, The influence of buffer species and strength on diltiazem HCl release from beads coated with the aqueous cationic polymer dispersions, Eudragit RS, RL 30D. *Pharm. Res.* 13: 52-56, 1996

Bommannan DB, Tamada J, Leung L and Potts RO, Effect of electroporation on transdermal iontophoretic delivery of lutenizing hormone releasing hormone (LHRH) *in vitro*. *Pharm. Res.* 11:1809, 1994

Burge G, Mendes R and Jambhekar S, Investigation of the applicability of ion exchange resins as a sustained release drug delivery system for propranolol hydrochloride. *Drug Dev. Ind. Pharm.* 12: 713-732, 1986

Burnette R, Transdermal drug delivery. In *Drug Delivery Reviews*. Hadgraft J and Guy RH (eds.), Marcel Dekker Inc. New York, USA, 247-292, 1988

Charman WN, Christy DP, Geunin EP and Monkhouse DC, Interaction between calcium, a model divalent cation, and a range of poly(acrylic acid) resins as a function of solution pH. *Drug Dev. Ind. Pharm.* 17: 271-280, 1991

Chaudhry NC and Saunders L, Sustained release of drugs from ion exchange resins. *J. Pharm. Pharmacol.* 38: 975-986, 1986

Chen L, Yang G and Zhang J, A study on the exchange kinetics of ion-exchange fiber. *React. Funct. Polym.* 29: 139-144, 1996

Conaghey OM, Corish J and Corrigan OI, The release of nicotine from a hydrogel containing ion exchange resins. *Int. J. Pharm.* 170: 215-224, 1998a

Conaghey OM, Corish J and Corrigan OI, Iontophoretically assisted *in vitro* membrane transport of nicotine from a hydrogel containing ion exchange resins. *Int. J. Pharm.* 170: 225-237, 1998b

Cullander C, What are the pathways of iontophoretic current flow through mammalian skin? *Adv. Drug Del. Rev.* 9: 119-135, 1992

Delgado-Charro BM and Guy RH, Characterization of convective solvent flow during iontophoresis. *Pharm. Res.* 11: 929-935, 1994

Delgado-Charro B, Rodriguez-Bayon A and Guy RH, Iontophoresis of nafarelin: effects of current density and concentration on electrotransport *in vitro*. *J. Control. Rel.* 35: 35-40, 1995

Drayton CJ, Cumulative subject index and drug compendium. In Hansch C, Sammes PG, Taylor JB (eds.), *Comprehensive Medicinal Chemistry*. Vol. 6, Pergamon Press, Oxford, 1990

- Ekman K, Applied radiation processing of polyolefins. Åbo Akademis Tryckeri, Åbo, 1994
- Fang JY, Sung KC, Lin HH and Fang CL, Transdermal iontophoretic delivery of diclofenac sodium from various polymer formulations: *in vitro* and *in vivo* studies. Int. J. Pharm. 178: 83-92, 1999
- Fessenden RJ and Fessenden JS, Organic Chemistry (fourth edition). Brooks/Cole Publishing Company, California, USA, p. 507, 1990
- Fiset P, Cohane C, Browne S, Brand SC and Shafer SL, Biopharmaceutics of a new transdermal fentanyl device. Anesthesiology 83: 459-469, 1995
- Florence AT and Attwood D, Physicochemical Principles of Pharmacy (third edition). Creative Print & Design, Great Britain, 1998
- Forsyth DR, Ford JM, Truman CA, Roberts CJC and Wilcock GK, Determination of tacrine hydrochloride in human serum by chloroform extraction, reverse-phase high-performance liquid chromatography and fluorometric detection. J. Chromatogr. 433: 352-358, 1988
- Franz TJ, Percutaneous absorption. On the relevance of *in vitro* data. J. Invest. Dermatol. 64: 190-195, 1975
- Franz TJ, The finite dose technique as a valid *in vitro* model for the study of percutaneous absorption in man. In Current Problems in Dermatology. Karger (ed.) 7: 58-68, 1978
- van der Geest R, van Laar T, Gubbens-Stibbe JM, Bodde HE and Danhof M, Iontophoretic delivery of apomorphine II: An *in vivo* study in patients with Parkinson's disease. Pharm. Res. 14: 1804-1810, 1997
- Glaser RW, Leikin SL, Chernomordik LV, Patushenko VF and Sokirko AJ, Reversible electrical breakdown of lipid bilayers: formation and evolution of pores. Biochim. Biophys. Acta 940: 275-287, 1988
- Gonzales-Tovar E, Lozada-Cassou M and Olivares W, Electrokinetic flow in ultrafine slits: Ionic size effects. J. Chem. Phys. 94: 2219-2231, 1991
- Green PH, Hinz RS, Cullander C, Yamane G and Guy RH, Iontophoretic delivery of amino acid derivatives across the skin *in vitro*. Pharm. Res. 9: 1113-1120, 1991
- Green P, Shroot B, Bernerd F, Pilgrim WR and Guy RH, *In vitro* and *in vivo* iontophoresis of a tripeptide across nude rat skin. J. Control. Rel. 20: 209-217, 1992

Gummer CL, The *in vitro* evaluation of transdermal delivery. In Drug Delivery Reviews. Hadgraft J, Guy R H (eds.), Marcel Dekker. New York, pp. 177-196, 1988

Gupta SK, Bernstein KJ, Noorduin H, van Peer A, Sathyan G and Haak R, Fentanyl delivery from an electrotransport system: Delivery is a function of total current, not duration of current. J. Clin. Pharmacol. 38: 951-958, 1998

Guy RH, A sweeter life for diabetics? Nature Medicine 11: 1132-1133, 1995

Guy RH, Carlström EM, Bucks DAW, Hinz RS and Maibach HI, Percutaneous penetration of nicotines: *in vivo* and *in vitro* measurements. J. Pharm. Sci. 75: 968-972, 1986

Guy RH and Hadgraft J, Selection of drug candidates for transdermal drug delivery. In Transdermal Drug Delivery. Hadgraft J and Guy RH (eds.), Marcel Dekker Inc., New York, USA, pp. 59-81, 1989

Guy RH and Hadgraft J, Rate-control in transdermal drug delivery. Int. J. Pharm. 82: R1-R6, 1992

Guy RH, Kalia YN, Delgado-Charro BM, Merino V, Lopez A and Marro D, Iontophoresis: electrorepulsion and electroosmosis. J. Control. Rel. 64: 129-132, 2000

Hadgraft J, Recent developments in topical and transdermal delivery. Eur. J. Drug Metab. Pharmacokin. 21: 165-173, 1996

Helferich F, Ion Exchange. Dover Publications Inc., New York, 1995

Hirvonen J, Kontturi K, Murtomäki L, Paronen P and Urtti A, Transdermal iontophoresis of sotalol and salicylate; the effect of skin charge and penetration enhancers. J. Control. Rel. 26: 109-117, 1993

Hirvonen J and Guy RH, Iontophoretic delivery across the skin: electroosmosis and its modulation by drug substances. Pharm. Res. 14: 1258-1263, 1997

Hirvonen J, Kalia YN and Guy RH, Transdermal delivery of peptides by iontophoresis. Nature Biotech. 14: 1710-1713, 1996

Hirvonen J and Jaskari T, New approaches in transdermal drug delivery. Eur. Pharm. Rev. 2: 68-70, 2001

Hildreth D, Electrokinetic flow in fine capillary channels. J. Phys. Chem. 9: 2006-2015, 1970

- Hoogstraate AJ, Srinivasan V, Simms SM and Higuchi WI, Iontophoretic enhancement of peptides: behavior of leuprolide versus model permeants. *J. Control. Rel.* 31: 41-47, 1994
- Hovorka SW and Schöneich C, Oxidative degradation of Pharmaceuticals: theory, mechanisms and inhibition. *J. Pharm. Sci.* 90:253-269, 2001
- Hänninen K, Lahtinen K, Jaskari T and Hirvonen J, Controlled release of salicylic acid derivatives with anion-exchange Fibers. *Eur. J. Pharm. Sci.* S31, 2001
- Illum L, Nasal drug delivery composition containing nicotine. US Patent 5,935,604, 1996
- Irwin WJ, Belaid KA and Alpar HO, Drug-delivery by ion-exchange. Part III: Interaction of ester pro-drugs of propranolol with cationic exchange resins. *Drug Dev. Ind. Pharm.* 13: 2047-2066, 1987
- Irwin WJ, MacHale R and Watts PJ, Drug-delivery by ion-exchange. Part VII: Release of acidic drugs from anionic exchange resin complexes. *Drug Dev. Ind. Pharm.* 16: 883-898, 1990
- Jani R, Gan O, Ali Y, Rodstrom R and Hancock S, Ion exchange resins for ophthalmic delivery. *J. Ocul. Pharmacol.* 10: 57-67, 1994
- Jenquin MR, Liebowitz SM, Sarabia RE and McGinity JW, Physical and chemical factors influencing the release of drugs from acrylic resin films. *J. Pharm. Sci.* 79: 811-816, 1990
- Jones C, Burton MA, Gray BN and Hodgkin J, *In vitro* release of cytotoxic agents from ion exchange resins. *J. Control. Rel.* 8: 251-257, 1989
- Joshi A, Microparticulates for ophthalmic drug delivery. *J. Ocul. Pharmacol.* 10: 29-45, 1994
- Kafil JB and Dhingra BS, Stability-indicating method for the determination of levodopa, levodopa-carbidopa and related impurities. *J. Chromatogr. A* 667: 175-181, 1994
- Kontturi K and Murtomäki L, Mechanistic model for transdermal transport including iontophoresis. *J. Control. Rel.* 41: 177-185, 1996
- Kriwet B and Kissel T, Interactions between bioadhesive poly(acrylic acid) and calcium ions. *Int. J. Pharm.* 127: 135-145, 1996
- Lakshminarayanaiah N, Equations of Membrane Biophysics. Academic, Orlando, Florida, 1984

Ledger PW, Skin biological issues in electrically enhanced transdermal delivery. *Adv. Drug Del. Rev.*, 9: 289-307, 1992

Lin W and Hsieh YL, Kinetics of metal ion adsorption on ion-exchange and chelating fibers. *Ind. Eng. Chem. Res.* 35: 3817-3821, 1996

Lin W, Cormier M, Samiee A, Griffin A, Johnson B, Teng CL, Hardee GE and Daddona PE, Transdermal delivery of antisense oligonucleotides with microprojection patch (Macroflux[®]) technology. *Pharm. Res.* 18: 1789-1793, 2001

Lu FM, Lee D, Carlson R, Rao S, Hui W, Adjei L, Herrin M, Sundberg D and Hsu L, The effects of formulation variables on iontophoretic transdermal delivery of leuprolide to humans. *Drug Dev. Ind. Pharm.* 19: 1557-1571, 1993

Luzardo-Alvarez A, Rodríguez-Fernández M, Blanco-Méndez J, Guy RH and Delgado-Charro MB, Iontophoretic permselectivity of mammalian skin: Characterization of hairless mouse and porcine membrane models. *Pharm. Res.* 15: 984-987, 1998

Lyklema J, *Fundamentals of Colloid and Interface Science*. Vol. 1, Academic, London, 1991

Magnusson BM and Koskinen LOD, *In vitro* percutaneous penetration of topically applied capsaicin in relation to *in vivo* sensation responses. *Int. J. Pharm.* 195: 55-62, 2000

Manning GS, Model for electro-osmosis in fixed-charge systems. *J. Chem. Phys.* 12: 4976-4980, 1967

Marchal-Heussler L, Colling N, Benoit E, Maincent P and Bessiere J, Applicability of dielectric measurements to the adsorption of beta blockers onto a pharmaceutical grade ion-exchange resin. *Pharm. Res.* 9: 1144-1147, 2000

Marro D, Guy RH and Delgado-Charro MB, Characterization of the iontophoretic permselectivity properties of human and pig skin. *J. Control. Rel.* 70: 213-217, 2001

Martin A, *Physical Pharmacy* (fourth edition). Williams & Wilkins, Baltimore, USA, pp. 169-190, 1993

McDowall RD, Sample preparation for biomedical analysis. *J. Chromatogr.* 492: 3-58, 1989

The Merck Index 12th. Merck & Co., USA, pp. 5490-5491, 5999, 1996

Miller LL, Kolaskie CJ, Smith GA and Rivier J, Transdermal iontophoresis of gonadotropin releasing hormone (LHRH) and two analogues. *J. Pharm. Sci.* 6: 490-493, 1990

- Mitragotri S, Effect of therapeutic ultrasound on partition and diffusion coefficients in human stratum corneum. *J. Control. Rel.* 71: 23-29, 2001
- Mizushima Y, Kosaka Y, Hosokawa K, Nagata R, Higaki M, Igarashi R and Ebata T, Medicaments for nasal administration, US Patent 5,942,242, 1996
- Mäki-Arvela P, Salmi T, Sundell M, Ekman K, Peltonen R and Lehtonen J, Comparison of polyvinylbenzene and polyolefin supported sulphonic acid catalysts in the esterification of acetic acid. *Appl. Catal. A: General* 184: 25-32, 1999
- Notari RE, Rates, rate constant and order. In *Biopharmaceutics and Clinical Pharmacokinetics* (fourth edition). Marcel Dekker, Inc., New York and Basel, pp. 6-21, 1987
- Ocak F and Ağabeyoğlu, Development of a membrane-controlled transdermal therapeutic system containing isosorbide dinitrate. *Int. J. Pharm.* 180: 177-183, 1999
- Padmanabhan RV, Phipps JB, Lattin GA and Sawchuk RJ, *In vitro* and *in vivo* evaluation of transdermal iontophoretic delivery of hydromorphone. *J. Control. Rel.* 11: 123-135, 1990
- Peck KD, Hsu J, Li SK, Ghanem AH and Higuchi WI, Flux enhancement effects of ionic surfactants upon passive and electroosmotic transdermal transport. *J. Pharm. Sci.* 87: 1161-1169, 1998
- Pikal MJ, Transport mechanisms in iontophoresis. I. A Theoretical model for the effect of electroosmotic flow on flux enhancement in transdermal iontophoresis. *Pharm. Res.* 7: 118-126, 1990
- Pikal MJ, The role of electroosmotic flow in transdermal iontophoresis. *Adv. Drug Del. Rev.* 9: 201-237, 1992
- Phipps BJ and Gyory RJ, Transdermal ion migration. *Adv. Drug Del. Rev.* 9: 137-176, 1992
- Prausnitz MR, The effects of electric current applied to skin: A review for transdermal drug delivery. *Adv. Drug Del. Rev.* 18: 395-425, 1996a
- Prausnitz MR, Lee C, Liu CH, Pang JC, Singh TP, Langer R and Weaver JC, Transdermal transport efficiency during skin electroporation and iontophoresis. *J. Control. Rel.* 38: 205-217, 1996b
- Prausnitz MR, Electroporation. In *Electronically Controlled Drug Delivery*. Berner B and Dinh SM (eds.), CRC Press, USA, 185-214, 1998

- Prot O, Benoit E, Maincent P and Bessiere J, Adsorption of beta-blockers onto poly(isobutylcyanoacrylate) nanoparticles: adsorption model and dielectric interpretation. *J. Colloid. Interf. Sci.* 184: 251-258, 1996
- Raghunathan Y, Amsel L, Hinsvark O and Bryant W, Sustained-release drug delivery system I: Coated ion-exchange resin system for phenylpropanolamine and other drugs. *J. Pharm. Sci.* 70: 379-384, 1981
- Ranade VV, Drug delivery systems. 6. Transdermal drug delivery. *J. Clin. Pharmacol.* 31: 401-418, 1991
- Rao G, Guy RH, Glikfeld P, LaCourse WR, Leung L, Tamada J, Potts RO and Azimi N, Reverse iontophoresis: Noninvasive glucose monitoring *in vivo* in humans. *Pharm. Res.* 12: 1869-1873, 1995
- Rautio J, Taipale H, Gynther J, Vepsäläinen J, Nevalainen T and Järvinen T, In vitro evaluation of acyloxyalkyl esters as dermal prodrugs of ketoprofen and naproxen. *J. Pharm. Sci.* 87: 1622-1628, 1998
- Riviere JE, Sage BH and Monteiro-Riviere NA, Transdermal lidocaine iontophoresis in isolated perfused porcine skin. *J. Toxicol. Cut. Ocular. Toxicol.* 9: 493-504, 1990
- Riviere JE, Sage B and Williams PL, Effects of vasoactive drugs on transdermal lidocaine iontophoresis. *J. Pharm. Sci.* 80: 615-620, 1991
- Rohr UD, Altenburger R and Kissel T, Pharmacokinetics of the transdermal reservoir membrane system delivering β -estradiol: *In vitro/in vivo*-correlation. *Pharm. Res.* 15: 877-882, 1998
- Rolf D, Chemical and physical methods of enhancing transdermal drug delivery. *Pharm. Tech.* 11:130-140, 1988
- Santi P and Guy RH, Reverse iontophoresis – parameters determining electroosmotic flow: I. pH and ionic strength. *J. Control. Rel.* 38: 159-165, 1996
- Sathyan G, Ritschel WA and Hussain AS, Transdermal delivery of tacrine. I Identification of a suitable delivery vehicle. *Int. J. Pharm.* 114: 75-83, 1995
- Sawaya A, Fickat R, Benoit JP, Puisieux F and Benita S, Ion-exchange albumin microcapsules of doxorubicin: an *in vitro* release kinetic evaluation. *J. Microencapsulation* 5: 255-267, 1988
- Sims SM, Higuchi WI and Srinivasan V, Skin alteration and convective solvent flow effects during iontophoresis: I. Neutral solute transport across human skin. *Int. J. Pharm.* 69: 109-121, 1991

Singh J, Dinh M and Berner B, Electrical properties of skin. In Electronically Controlled Drug Delivery. Berner B and Dinh S (eds.), CRC Press, USA, 47-61, 1998

Singh P and Maibach HI, Iontophoresis in drug delivery: Basic principles and applications. *Therap. Drug Carrier Syst.* 11: 161-213, 1994

Sprockel OL and Price JC, Evaluation of sustained release aqueous suspensions containing microencapsulated drug-resin complexes. *Drug Dev. Ind. Pharm.* 15: 1275-1287, 1989

Srinivasan V, Higuchi W, Sims S, Ghanem A and Behl C, Transdermal iontophoretic drug delivery: Mechanistic analysis and application to polypeptide delivery. *J. Pharm. Sci.* 78: 370-375, 1989

Srinivasan V and Higuchi W, A model for iontophoresis incorporating the effect of convective solvent flow. *Int. J. Pharm.* 60: 133-138, 1990

Sriwongjanya M and Bodmeier R, Effect of ion exchange resins on the drug release from matrix tablets. *Eur. J. Pharm. Biopharm.* 46: 321-327, 1998

Sugar IP, A theory of the electric field-induced phase transition of phospholipid bilayers. *Biochim. Biophys. Acta* 556: 72-85, 1979

Suhonen M, Bouwstra JA and Urtti A, Chemical enhancement of percutaneous absorption in relation to stratum corneum structural alterations. *J. Control. Rel.* 59: 149-161, 1999

Sundell MJ, Ekman KB, Svarfvar BL and Näsman JH, Preparation of poly[ethylene-g-(vinylbenzyl chloride)] and functionalization with bis(phosphonic acid) derivatives. *React. Polym.* 25: 1-16, 1995

Sundell M and Näsman JH, Anchoring catalytic functionality on a polymer. *Chemtech.* 16-23, 1993

Sutinen R, Urtti A, Miettunen R and Paronen P, Water-activated and pH-controlled release of weak bases from silicone reservoir devices. *Int. J. Pharm.* 62: 113-118, 1990

Sørensen TS and Rivera SR, In *Surface Chemistry and Electrochemistry of Membranes*. Sørensen TS (ed.), Marcel Dekker, New York, p. 350, 1999

Tamada JA, Bohannon NJV and Potts RO, Measurement of glucose in diabetic subjects using noninvasive transdermal extraction. *Nature Medicine* 1: 1198-1201, 1995

Teissie J and Tsong TY, Electric field induced transient pores in phospholipid bilayer vesicles. *Biochem.* 20: 1548-1554, 1981

Telting-Diaz M and Lunte CE, Distribution of tacrine across the blood-brain barrier in awake, freely moving rats using *in vivo* microdialysis sampling. *Pharm. Res.* 10: 44-48, 1993

Turner NG and Guy RH, Iontophoretic transport pathways: dependence on penetrant physicochemical properties. *J. Pharm. Sci.* 86: 1385-1389, 1997

Vanbever R, Pliquett UF, Preat V and Weaver JC, Comparison of the effects of short, high-voltage and long, medium-voltage pulses on the skin electrical and transport properties. *J. Control. Rel.* 60:35-47, 1999

Wagstaff AJ and McTavish D, Tacrine: a review of its pharmacokinetic properties, and therapeutic efficacy in Alzheimer's disease. *Drugs Aging* 4: 510-540, 1994

Walters KA, Penetration enhancers and their use in transdermal therapeutic systems. In *Transdermal Drug Delivery*. Hadgraft J and Guy RH (eds.), Marcel Dekker Inc., New York, USA, pp. 197-246, 1989

Wang DM, Lin FC, Chen LY and Lai JY, Application of asymmetric TPX membranes to transdermal delivery of nitroglycerin. *J. Control. Rel.* 50: 187-195, 1998

Åkerman S, Viinikka P, Svarfvar B, Järvinen K, Kontturi K, Näsman J, Urtti A and Paronen P, Transport of drugs across porous ion exchange membranes. *J. Control. Rel.* 50: 153-166, 1998

Åkerman S, Svarfvar B, Kontturi K, Näsman J, Urtti A, Paronen P and Järvinen K, Influence of ionic strength on drug adsorption onto and release from a poly(acrylic acid) grafted poly(vinylidene fluoride) membrane. *Int. J. Pharm.* 178: 67-75, 1999

Åkerman S, Temperature-, pH- and Ionic Strength- Responsive Grafted Polymer Membranes for Pharmaceutical Applications. Doctor's thesis, Kuopio University Printing Office, Kuopio 1999