

Helsinki Biomedical Graduate School
University of Helsinki, Finland



Helsinki University Biomedical Dissertations No. 130

**Genetic analysis of chromosomal regions 2q33, 7q32
and 19q13 in multiple sclerosis susceptibility**

Alessandro Bonetti

Research Program of Molecular Neurology, Biomedicum Helsinki

and

Department of Neurosciences, Institute of Clinical Medicine

University of Helsinki, Finland

ACADEMIC DISSERTATION

To be publicly discussed

with the permission of the Faculty of Medicine of the University of
Helsinki, for public examination in Biomedicum Helsinki, Lecture Hall 2,
on October 30th, 2009, at 12h00

Helsinki 2009

Supervised by

Docent (adjunct professor) Pentti Tienari MD PhD
Research Program of Molecular Neurology, Biomedicum Helsinki
University of Helsinki
and
Helsinki University Central Hospital, Department of Neurology
Finland

Reviewed by

Docent (adjunct professor) Jukka Partanen PhD
Finnish Red Cross Blood Service
Helsinki, Finland

and

Assistant professor Tomi Pastinen MD PhD
Departments of Human Genetics and Medical Genetics
McGill University and Genome Quebec Innovation Centre
Montreal, Canada

Discussed by

Docent (adjunct professor) Päivi Saavalainen PhD
Department of Medical Genetics
University of Helsinki
Finland

ISBN 978-952-10-5828-8 (paperback), ISBN 978-952-10-5829-5 (PDF)
ISSN 1457-8433

Helsinki University Print
Helsinki 2009

ACKNOWLEDGEMENTS

The work described in this thesis was carried out in the laboratory of Pentti Tienari at the Research Program of Molecular Neurology (formerly Neurosciences) in Biomedicum Helsinki between April 2003 and July 2009.

My acknowledgements start obviously from my supervisor Pentti Tienari. I deeply thank him for the resources and the help he provided, the discussions we engaged about science and subjects concerning other aspects of human activities. I thank my coauthors for their collaboration and interest. I am deeply grateful to the external reviewers of this thesis, adjunct prof. Jukka Partanen and assistant prof. Tomi Pastinen, for their availability, feedback and extremely quick response. I wish to express my gratitude and honor to adjunct prof. Päivi Saavalainen for accepting the post of opponent. My warm thanks to Prof. Anu Wartiovaara for accepting the kustos role and for “adopting” me in her group during the journal club series. I would like to express my heartfelt gratitude Dr. Brendan Battersby for the language review, the constant support he provided me with endless scientific questions and most importantly for being a real friend. I am grateful to Prof. Juha Kere for being a member of thesis committee and for his valuable comments and advices.

Helsinki Biomedical Graduate School is thanked for supporting my salary during four years. The Center for International Mobility, Emil Aaltonen Foundation, Sigfrid Juselius Foundation, Academy of Finland and Finnish Cultural Foundation are thanked for providing funds during the years.

A special “grazie” goes to Lilja Jansson for the help, the pain and the laugh shared during these six years: even when everything seemed to not work we were able to have genuine fun. And I cannot forget Hannele Pihlaja for the help given in the first part of my life spent in PT lab. KP for entertaining my working days with socio-cultural trivia and for sharing interesting scientific ideas, Terhi R-H for helping me out through the analysis of genetic results in the beginning of my PhD studies.

Now comes the difficult part. Being a social person exposes me to a plethora of individuals during and after my working hours. Every person crossing my path during these years has played a somewhat important role but it is practically impossible to mention everybody. Tatiana, you

brought in the last part of my studies a lot of energy and fun. Nuno and Zuzana, our discussion about science and most importantly life have not vanished from my memories; Iulia, Joao, Karen, Maurice and especially Vincenzo, you entertained my working hours with good laughs and more serious stuff. To all the past and present members of AW, BB and Iris Hovatta labs, thanks for tolerating my noisy presence throughout these years. To all the neurobastards (among which Annamari, Antti “the man”, Jana, Kati, Riikka, Sofia and Valtteri deserve special mention) that have been hanging out with me during the cold winter nights and the warm summer evenings, celebrating life has been pure enjoyment. I want to thank Anu H, Markus and Tuula for the expertise and help in every day working life, Joni and Chris for putting up with me in good and bad times, Anna H and Eino for sharing intriguing thoughts about the functioning of human body and especially Ilse and Paula for being true friends. To my past and present volley mates for enjoying victories and washing losses away with an adequate amount of ethanol, to my football team-mates (Dario, Ettore, Giulio, Massimo, Rosario, Simone) for unnecessarily spicing my summers up.

I still remember as if it was yesterday the moment I joined the lab of Prof. Tommaso Russo in Napoli. It was September 1998 and I was a young student full of hopes and dreams. I’m deeply indebted to him for guiding me through my master degree studies. It is still very clear in my memory the words he used to describe the “mission” of the scientist: we do this job because there’s a sacred fire burning in our chest. After eleven years that flame has not been extinguished yet. I cannot forget Dr. Giuseppina “Giusy” Minopoli, a fundamental person in my three years spent at the Department of Biochemistry and Molecular Biology. Then it’s the turn of my colleagues around the world, a proof of what our beloved country, Italy, has obliged us to do for finding proper personal scientific reward and dignity elsewhere: Karlo, Tapete, Tieghe, Elena, (viol)Enza, Eva, Luca, Mariah and Marsilio. The memories of those amazing years will never be forgotten.

I guess it’s time to wrap it up and finish by thanking my family. To my parents Gennaro and Marilena and to my sister Laura for supporting continuously me and my not-so-orthodox choices. All this rambling cannot be concluded without mentioning Mia, the person that has witnessed hopes and frustrations throughout these years.

Alessandro Bonetti

Helsinki, September 24th 2009

“Fatti non foste a viver come bruti ma per seguir virtute e canoscenza”

Your fate is not to rummage in the mud, yet to progress in moral value and knowledge

Dante Alighieri, *Divina Commedia*, Inferno canto XXVI 116-20

Life is what happens to you while you're busy making other plans

John Lennon in *Beautiful Boy*

Destroy the altar whose boundaries tides will never exceed,
ignite the pyres underneath a sedated mythology

Circle Takes The Square in *In The Nervous Light of Sunday*

And I knew the echo that is love
and I knew the secrets in your spires
and I knew the emptiness of youth
and I knew the solitude of heart
and I knew the murmurs of the soul

Billy Corgan in *Muzzle*

The definition of stupidity is doing the same thing
over and over again and expecting different results

Albert Einstein

TABLE OF CONTENTS

ACKNOWLEDGEMENTS	3
CONTENTS	7
LIST OF ORIGINAL PUBLICATIONS	9
ABBREVIATIONS	10
ABSTRACT	12
INTRODUCTION	14
REVIEW OF THE LITERATURE	15
1. Multiple sclerosis	15
1.1 Clinical aspects of MS	15
1.2 Basic features of MS lesions	16
1.3 Diagnostic laboratory tests	17
1.4 Therapy	19
2. Epidemiology	22
2.1 Incidence and prevalence	22
2.2 Migration studies	23
3. Environment and MS	24
3.1 Infectious agents	24
3.1.1 Virus	24
3.1.2 Bacteria	26
3.2 Sunlight and vitamin D	26
3.3 Other proposed environmental risk factors	27
4. Pathogenic mechanisms in MS	28
4.1 Immunopathophysiology of MS	29
4.1.1 Cell-mediated immune system	29
4.1.2 Role of regulatory T-cells	30
4.1.3 Humoral immune system	30
4.2 Role of CNS resident cells	31
4.3 Myelin and myelination	32
5. Genetics of MS	34
5.1 Family and twin studies	34

5.2 Strategies to identify disease genes	36
5.2.1 Linkage studies	36
5.2.2 Association studies	37
5.2.3 Role of genetic isolates	40
5.3 Role of HLA genes	40
5.4 Role of non-HLA genes	42
5.4.1 IL-7R	43
5.4.2 IL-2RA	44
5.4.3 Other genes	44
AIM OF THE PRESENT STUDY	48
MATERIALS AND METHODS	49
1. Subjects and families (I-IV)	49
2. DNA analysis (I-IV)	50
3. Statistical analyses (I-IV)	51
4. Electrophoretic mobility shift assay (EMSA) (II)	51
5. Proximity ligation assay (II)	51
6. Cell culture and T-cell activation (IV)	51
7. RNA extraction and reverse transcriptase polymerase chain reaction (RT-PCR) (IV)	52
8. Expression vectors (IV)	52
9. Transfection and cell localization (IV)	52
10. Gel electrophoresis and western blotting (IV)	53
RESULTS AND DISCUSSION	54
1. Chromosome 2q33 and MS	54
2. IRF5 gene and MS	61
3. Chromosome 19q13 and MS	65
CONCLUSIONS AND FUTURE PROSPECTS	70
REFERENCES	73
ORIGINAL PUBLICATIONS	85

LIST OF ORIGINAL PUBLICATIONS

This thesis is based on the followings articles, which are referred to in the text by their Roman numerals.

I. **Bonetti A**, Reunanen K, Finnilä S, Koivisto K, Wikström J, Sumelahti ML, Pirttilä T, Elovaara I, Reunanen M, Peltonen L, Rantamäki T, Tienari PJ. A two-stage study on multiple sclerosis susceptibility and chromosome 2q33. *Genes Immun* 5(2):142-6,2004.

II. Kristjansdottir G*, Sandling JK*, **Bonetti A**, Roos IM, Milani L, Wang C, Gustafsdottir SM, Sigurdsson S, Lundmark A, Tienari PJ, Koivisto K, Elovaara I, Pirttilä T, Reunanen M, Peltonen L, Saarela J, Hillert J, Olsson T, Landegren U, Alcina A, Fernández O, Leyva L, Guerrero M, Lucas M, Izquierdo G, Matesanz F, Syvänen AC. Interferon regulatory factor 5 (IRF5) gene variants are associated with multiple sclerosis in three distinct populations. *J Med Genet* 45(6):362-9,2008.

* Equal contribution

III. **Bonetti A**, Koivisto K, Pirttilä T, Elovaara I, Reunanen M, Laaksonen M, Ruutiainen J, Peltonen L, Rantamäki T, Tienari PJ. A follow-up study of chromosome 19q13 in multiple sclerosis susceptibility. *J Neuroimmunol* 208(1-2):119-24,2009.

IV. **Bonetti A**, Koivisto K, Pirttilä T, Elovaara I, Reunanen M, Rantamäki T, Tienari PJ. Novel alternatively spliced transcript of ICOS gene lacking exon 2, association analysis of CTLA4 and ICOS with multiple sclerosis. *Soon to be submitted*.

ABBREVIATIONS

BBB	Blood-brain barrier
CDCV	Common disease common variant
CLEC16A	C-type lectin domain family 16, member A
cM	CentiMorgan
CNS	Central nervous system
CSF	Cerebrospinal fluid
CTLA4	Cytotoxic T Lymphocyte Associated 4
DZ	Dizygotic twin
EAE	Experimental autoimmune encephalomyelitis
EBV	Epstein-Barr virus
ER	Endoplasmatic reticulum
EVI5	Ecotropic viral integration site 5
GA	Glatiramer acetate
GWAS	Genome-wide association study
HERV-W	Human endogenous retrovirus W
HHV-6	Human herpes virus 6
HLA	Human leukocyte antigen
HTLV	Human T-cell Lymphotropic Virus
ICOS	Inducible T-cell co-stimulator
IFN- β	Beta interferon
IFN- γ	Gamma interferon
IL-2RA	Interleukin 2 receptor alpha
IL-7R	Interleukin 7 receptor
IL-10	Interleukin 10
IBD	Inflammatory bowel disease
IgG	Immunoglobulin G
IRF5	Interferon regulatory factor 5
KIF1B	Kinesin family member 1B
KO	Knockout
LD	Linkage disequilibrium
LINGO-1	Leucine-rich repeat and Ig-domain-containing, Nogo receptor-interacting

	protein
LPS	Lipopolysaccharide
MAF	Minor allele frequency
MBP	Myelin basic protein
MHC	Major histocompatibility complex
MHC2TA	Major Histocompatibility Complex Trans-Activator 2A
MRI	Magnetic resonance imaging
MS	Multiple sclerosis
MSRV	MS-associated retrovirus
MZ	Monozygotic twin
OB	Oligoclonal band
PLOSL	Polycystic lipomembranous osteodysplasia with sclerosing leukoencephalopathy
PML	Progressive multifocal leukoencephalopathy
PBS	Phosphate-buffered saline solution
PMS	Primary progressive multiple sclerosis
RA	Rheumatoid arthritis
RPL5	Ribosomal protein L5
RRMS	Relapsing remitting multiple sclerosis
SLE	Systemic lupus erythematosus
SNP	Single nucleotide polymorphism
T1D	Type 1 diabetes
TCR	T-cell receptor
TDT	Transmission disequilibrium test
TLR	Toll-like receptor
TNF α	Tumor necrosis factor alpha
TNFRSF1A	Tumor necrosis factor receptor superfamily member 1A
Treg	Regulatory T-cell
UTR	Untranslated region
VDRE	Vitamin D regulatory element
VLA-4	α 4 β 1 integrin very late antigen 4

ABSTRACT

Multiple sclerosis (MS) is an immune-mediated demyelinating disorder of the central nervous system (CNS) affecting 0.1-0.2% of Northern European descent population. MS is considered to be a multifactorial disease, both environment and genetics play a role in its pathogenesis. Despite several decades of intense research, the etiological and pathogenic mechanisms underlying MS remain still largely unknown and no curative treatment exists.

The genetic architecture underlying MS is complex with multiple genes involved. The strongest and the best characterized predisposing genetic factors for MS are located, as in other immune-mediated diseases, in the major histocompatibility complex (MHC) on chromosome 6. In humans MHC is called human leukocyte antigen (*HLA*). Alleles of the *HLA* locus have been found to associate strongly with MS and remained for many years the only consistently replicable genetic associations. However, recently other genes located outside the MHC region have been proposed as strong candidates for susceptibility to MS in several studies.

In this thesis a new genetic locus located on chromosome 7q32, *interferon regulatory factor 5* (*IRF5*), was identified in the susceptibility to MS. In particular, we found that common variation of the gene was associated with the disease in three different populations, Spanish, Swedish and Finnish. We also suggested a possible functional role for one of the risk alleles with impact on the expression of the *IRF5* locus.

Previous studies have pointed out a possible role played by chromosome 2q33 in the susceptibility to MS and other autoimmune disorders. The work described here also investigated the involvement of this chromosomal region in MS predisposition. After the detection of genetic association with 2q33 (article-1), we extended our analysis through fine-scale single nucleotide polymorphism (SNP) mapping to define further the contribution of this genomic area to disease pathogenesis (article-4). We found a trend ($p=0.04$) for association to MS with an intronic SNP located in the inducible T-cell co-stimulator (*ICOS*) gene, an important player in the co-stimulatory pathway of the immune system. Expression analysis of *ICOS* revealed a novel, previously uncharacterized, alternatively spliced isoform, lacking the extracellular domain that is needed for ligand binding. The stability of the newly-identified transcript variant and its subcellular localization were analyzed. These studies indicated that the novel isoform is stable

and shows different subcellular localization as compared to full-length ICOS. The novel isoform might have a regulatory function, but further studies are required to elucidate its function.

Chromosome 19q13 has been previously suggested as one of the genomic areas involved in MS predisposition. In several populations, suggestive linkage signals between MS predisposition and 19q13 have been obtained. Here, we analysed the role of allelic variation in 19q13 by family based association analysis in 782 MS families collected from Finland. In this dataset, we were not able to detect any statistically significant associations, although several previously suggested markers were included to the analysis. Replication of the previous findings on the basis of linkage disequilibrium between marker allele and disease/risk allele appears notoriously difficult because of limitations such as allelic heterogeneity. Re-sequencing based approaches may be required for elucidating the role of chromosome 19q13 with MS.

This thesis has resulted in the identification of a new MS susceptibility locus (*IRF5*) previously associated with other inflammatory or autoimmune disorders, such as SLE. *IRF5* is one of the mediators of interferons biological function. In addition to providing new insight in the possible pathogenetic pathway of the disease, this finding suggests that there might be common mechanisms between different immune-mediated disorders. Furthermore the work presented here has uncovered a novel isoform of ICOS, which may play a role in regulatory mechanisms of ICOS, an important mediator of lymphocyte activation. Further work is required to uncover its functions and possible involvement of the ICOS locus in MS susceptibility.

INTRODUCTION

Multiple sclerosis (MS) is a chronic, demyelinating condition of the central nervous system with putative autoimmune pathogenesis and unknown etiology. With a prevalence of about 1 in 1000 individuals of Northern European descent, MS is the most common disorder of neurological disability in young adults. The disease has a highly variable clinical course. Both environmental and genetic factors are thought to be involved in its pathogenesis. Although it has been intensively studied in the last decades, the molecular mechanisms underlying MS are still largely unknown.

The complex nature of MS complicates the study of individual genes and their contribution in the disease process. However, in recent years molecular genetic tools have provided scientists with new means for identifying genetic factors involved in susceptibility to complex disorders. The aim of this thesis work was to dissect other possible MS predisposing loci by integrating both genetic and molecular biology approaches. Recently it has become evident that the genetic mapping of common disorders greatly benefits from the integration of different methods and techniques.

Previous studies performed in several populations have pointed out a possible role played by 2q33 and 19q13 chromosomal regions in the predisposition to MS and other autoimmune disorders. Interferon response factor-5 (IRF5) gene was analysed based on previous evidence suggesting that allelic variation of IRF5 contributes to the archetypal autoimmune disease, systemic lupus. In this thesis we tested whether these loci would be involved in the genetic predisposition of MS. A better understanding of MS susceptibility might shed new light into the pathogenesis and treatment of the disease and even provide new tools to identify individuals at higher risk for possible preventive strategies.

REVIEW OF THE LITERATURE

1. MULTIPLE SCLEROSIS

1.1 CLINICAL ASPECTS

Multiple sclerosis (MS) is a chronic inflammatory disorder of the central nervous system (CNS) resulting in loss of myelin sheath (demyelination) and axonal damage. It typically begins between the ages of 20 and 40 and manifests with different clinical symptoms. It can be clinically categorized as either relapsing-remitting MS (RRMS, observed in 85-90% of patients) or primary progressive MS (PPMS). Despite intense research the etiology remains unknown, the pathogenesis is still unclear and at the moment no curative treatment is available.

The credit for the clinico-pathological characterization of MS belongs the French pathologist Jean-Martin Charcot in 1868. He coined the term “multiple sclerosis” (in French “sclèrose en plaques”) referring to the scars (scleroses, also known as plaques or lesions) in the white matter of patients’ brain and spinal cord.

MS is slightly more common in females than in males with a female:male ratio of approximately 2:1. MS symptoms normally occur in episodic acute periods of worsening (relapses), in the gradually progressive loss of neurological functions, sometimes in combination of both. MS patients can suffer from a wide spectrum of neurological symptoms. The initial signs vary greatly between patients and even from one attack to another in the same person. The most common symptoms are changes in sensation (numbness and paresthesiae), impaired vision, difficulties with coordination and balance (ataxia), pareses, fatigue and incontinence.

MS can be difficult to diagnose since its symptoms and signs may overlap with other medical conditions. As there is no specific single laboratory test, the diagnosis of MS is mostly done by combining clinical and “paraclinical” information, such as magnetic resonance imaging (MRI) and analysis of the cerebrospinal fluid (CSF). This has led to the establishment of diagnostic criteria for the needs of clinicians. Historically Schumacher’s criteria (1965) have initially been applied in clinical practice and later replaced by the newer guidelines suggested by Poser and colleagues (1983) with different degrees of diagnostic certainty (clinically possible MS, clinically probable MS, laboratory-supported definite MS, and finally the most certain diagnostic

level clinically definite MS). More recently other criteria combining clinical, laboratory and especially MRI data have been introduced to facilitate the early diagnosis of MS in patients who presents symptoms that might be suggestive of the disease (McDonald et al 2001).

1.2 BASIC FEATURES OF THE MS LESIONS

One of the hallmarks of MS is the presence of large, multifocal, sharp-edged, demyelinated plaques with reactive glial scar formation (Compston et al 2006). These characteristic lesions are accompanied by the infiltration of inflammatory mediators, mainly T-cells and macrophages. Active lesions, defined by the ongoing destruction of myelin, are populated by macrophages and activated microglial cells, whereas in advanced inactive plaques the centre of the lesion is characterized by gliotic astrocytic fibers. Although myelin sheaths are the primary target of the inflammatory process, the axons beneath the myelin, cortical neurons and astrocytes are also affected. In fact demyelination can be partially repaired by remyelination but axonal destruction is irreversible and responsible for the accumulation of the neurological deficits.

Lucchinetti et al (2000) analyzed the pathology of archival material consisting of 51 biopsies and 32 autopsies "with histologically proven active MS". Four different patterns of demyelination were found using immunological and neurological markers (Table 1).

The analysis of Lucchinetti et al (2000) revealed heterogeneity in patterns of demyelination between different patients, whereas multiple active lesions from the same patient were very similar. In the first pattern, demyelination is induced by the release of cytokines, enzymes and reactive oxygen intermediates from activated macrophages. The second pattern is caused by myelin-reactive antibodies and activated complement. In the third pattern white matter ischemia or viral infection induces apoptosis of oligodendrocytes. The last pattern is caused by deficiency in oligodendrocytes metabolism and a subsequent higher vulnerability to the toxic action of inflammatory mediators. All these patterns may result in axonal injury that follows the acute destruction of myelin sheaths with permanent neurological dysfunction. It should be noted that many of the samples were biopsies taken for diagnostic purpose. Biopsy, *per se*, is an indication of atypical features of demyelinating disease, biopsy is not typically used in the normal diagnostic work-up of MS. Therefore, this study has been criticized for the possible inclusion of non-MS cases, especially disseminated encephalomyelitis cases (Poser 2000).

<i>PATTERNS OF DEMYELINATION</i>	<i>PATHOLOGY</i>	<i>PUTATIVE MECHANISMS</i>
(I) Macrophage mediated	Inflammatory infiltrates composed of T-cells and macrophages; activated macrophages and microglia. Signs of remyelination.	T-cell mediated activation of macrophages and microglia, which secrete myelinotoxic substances.
(II) Antibody mediated	Similar lesions as in (I) with additional deposition of antibodies and activated complement. Signs of remyelination.	T- and B-cell mediated inflammation with demyelination mediated by antibody-targeted complement.
(III) Distal oligodendropathy	Inflammatory infiltrates composed of T-cells and macrophages with small vessel vasculitis and degenerating apoptotic oligodendrocytes.	T-cell mediated vasculitis with secondary ischemic damage of the white matter.
(IV) Primary oligodendrocyte damage with secondary demyelination	Similar lesions as in (I) with prominent oligodendrocyte degeneration, no remyelination.	Oligodendrocytes are metabolically impaired. Secondary T-cell mediated inflammation with activation of macrophage and microglia.

Table 1. Different patterns of demyelination in active MS plaques observed in the series of Lucchinetti et al (2000).

In another study of 39 patients, diagnosed (antemortem) as clinically definite MS and subsequently neuropathologically analysed, similar heterogeneity of MS lesions was not found (Breij et al, 2008). In these subjects the dominant pattern of active demyelination was similar to the type II pattern above. Active complement, immunoglobulin G (IgG) and activated macrophages/microglia were consistently found. Signs of ischemia (type III) or oligodendrocyte apoptosis (type III and IV) were not found. Hence, it is still debatable, whether all four patterns of demyelination occur in MS.

1.3 DIAGNOSTIC LABORATORY TESTS

MS patients are characterized by the occurrence of several immunological abnormalities involving both humoral and cell-mediated immune systems. One of the laboratory parameters that best correlates with MS is the presence of oligoclonal bands (OBs). OBs are clusters of immunoglobulins that are detected from CSF and serum with the help of isoelectric focusing. Visually OBs appear as discrete bands that stand out from the background in the gel. OBs present in the CSF, but not in the serum, indicate the presence of antibody producing plasma

cells in the CNS. CSF specific OBs are found in 90% MS patients. However, such Obs are found in other conditions as well (e.g. neurosarcoidosis, neuroborreliosis, stiff-person syndrome, chronic meningitis). Another measure of immunoactivation is the increased CSF/serum IgG ratio (IgG-index) that indicates increased overall production of antibodies within the CNS. In terms of banding patterns, *post-mortem* samples from the CNS of an MS patient have revealed that distinct OB-patterns are found in individual plaques, a finding in contrast to the notion of an immune reaction against a common epitope (Mattson et al 1990).

So far no clear picture has emerged from the analysis of the specificity of the OBs. Quite commonly IgG recognizing common viruses such as measles and varicella are found but these antibodies constitute only a minor fraction of OBs. Cortese and co-workers (1996) have utilized a strategy based on phage-displayed random peptide libraries to identify ligands for OBs from MS patients. The purified epitopes were recognized with equal frequency by the sera of normal individuals and MS patients. Furthermore the repertoire of CSF antibodies appeared to be individual-specific, suggesting a nonspecific immunedysregulative phenomenon rather than the result of an immune reaction towards a common antigen.

Magnetic resonance imaging (MRI) is very sensitive for detecting lesions in the brains of MS patients. In MRI using T2-weighted and FLAIR sequences MS plaques appear as brighter areas surrounded by normal-appearing white matter which looks darker; the rationale for this is the increased water content of the lesions which may be secondary to inflammation or gliosis (Figure 1).

For detection of very young lesions paramagnetic substances such as gadolinium can be used to demonstrate blood-brain barrier (BBB) leakage. The extent of the plaques as visualized with MRI does not always correlate with the clinical picture of the patient. Many plaques are clinically silent. Even large lesions may be symptomless, while a small plaques in a critical anatomical site (e.g. brain stem, spinal cord) may have a strong impact on the neurological functions. Also in the case of MRI diagnostics the lesions are not 100% specific for MS, with other conditions (e.g. cerebral vasculitis, sarcoidosis) having sometimes a similar pattern (Miller et al 1988). The MRI criteria by Barkhof et al (1997) are recommended in the contemporary McDonald's criteria of MS. These MRI criteria pay special attention to the anatomical dissemination of lesions. They were originally designed for the prediction of future MS in

patients with first clinical symptom suggesting demyelinating disease (so called clinically isolated syndrome).

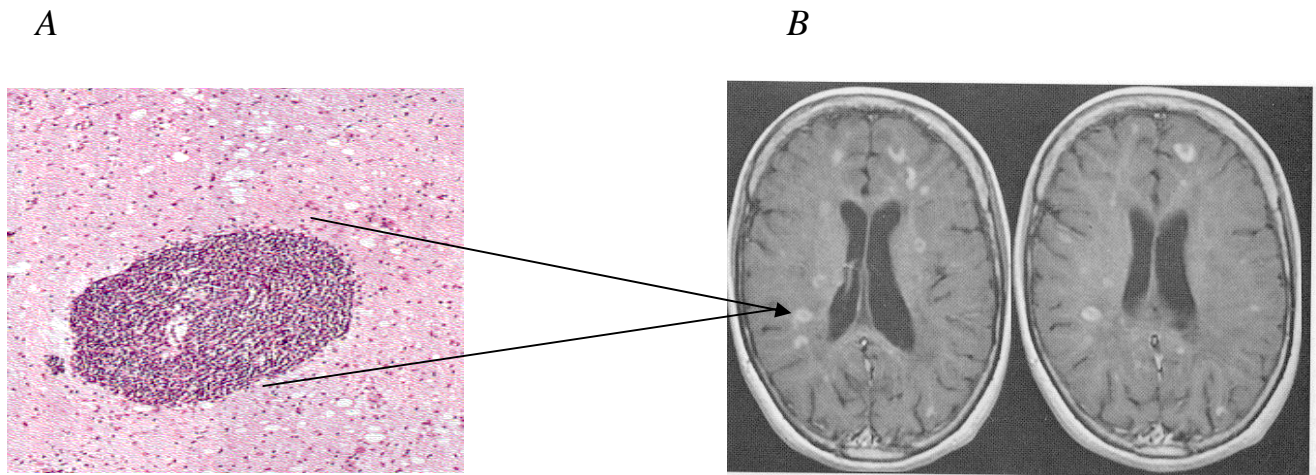

Figure 1. A. Typical sharp-edged leukocyte extravasation around a small calibre vein. B. MRI scans of brains of MS patients (FLAIR sequence) showing multiple periventricular and juxtacortical plaques. Many of the early plaques are composed of the infiltrating perivascular leukocytes indicated by arrows (Pictures from Pentti Tienari, University of Helsinki).

1.4 THERAPY

Relapses are often treated with high-dose corticosteroids for a few days. This treatment speeds up patients' recovery from the relapse but it is presumed that treatment of corticosteroids at relapses does not have impact on the long-term prognosis. Several drugs have been developed to improve long-term prognosis of MS. Current MS therapies are immunomodulatory strategies to partially protect against relapses and MRI burden, but their effect on long-term prognosis is still somewhat unclear. These drugs are ineffective against purely progressive forms of MS. The inflammatory nature of MS has been instrumental in leading to the drug treatments presently used, but the lack of a detailed understanding of the disease's pathophysiology has prevented the design of more effective therapies. Currently two classes of immunomodulating first-line strategies are used to impact the early course of MS: β -interferons (IFN- β s) and glatiramer acetate.

The rationale for using beta-interferon (IFN- β) in MS came partly from a treatment trial with gamma-interferon (IFN- γ), which dramatically increased the relapse-rate of MS patients (Panitch

et al, 1987) (the trial was discontinued). Since IFN- β is partially antagonising the effects of IFN- γ , it turned out to be a natural candidate for MS treatment. IFN- β is an anti-inflammatory regulatory cytokine with antiviral, antineoplastic and immunomodulatory effects. It decreases cell migration into CNS, inhibits T-cells proliferation and expression of cell activation markers and increases the synthesis of the anti-inflammatory cytokine interleukin 10 (IL-10) and nerve growth factor, possibly inducing remyelination and axonal repair (Rudick 1999). The results of different clinical trials with RRMS patients have shown a beneficial effect of IFN- β for the attack rates and disease activity measured clinically or by MRI (The IFNB study group 1995, Rudick et al 1997), whereas for the treatment of PPMS patients IFN- β has shown to be not effective (Miller et al 2007).

The alternate drug in first-line treatment is the use of glatiramer acetate (GA), a synthetic peptide that mimics the epitopes of myelin basic protein (MBP) and other myelin proteins. GA is a random polymer of the four amino acids Glutamate, Lysine, Alanine and Tyrosine (hence the name GLATiramer). The rationale for using GA in MS therapy stems from the idea that autoimmunity against myelin protein, especially MBP, plays an essential role in MS pathogenesis (Lisak et al., 1977). GA is designed to act as a decoy for MBP, diverting the inflammatory response against myelin. Recently it has been shown that GA increases the circulating levels of the secreted form of IL-1 receptor antagonist and therefore triggers a less inflammatory profile (Burger et al 2009). In clinical trials GA has been shown to be as effective as β interferon to reduce the number and severity of exacerbations in RRMS (Mikol et al 2008) but failed to demonstrate a treatment effect in PPMS (Wolinsky et al 2007).

Natalizumab is indicated for patients with very aggressive relapsing-remitting MS, who do not respond to IFN- β or GA. In the pivotal clinical trial it showed the strongest drug effect thus far obtained in reducing relapse rate and MRI activity (Polman et al. 2006). The rationale is to prevent circulating leukocytes from migrating to the CNS. Natalizumab is a humanized monoclonal antibody directed against the $\alpha 4\beta 1$ integrin very late antigen 4 (VLA-4). VLA-4 is expressed particularly on T-cells where it has a crucial role in the BBB transmigration (Ransohoff 2007): the blockade of VLA-4 inhibits the entrance of immune cells in the CNS and ameliorates the disease course. After a successful Phase III study, two cases of progressive multifocal leukoencephalopathy (PML) occurred with the subsequent withdrawal of the drug from the market (Langer-Gould et al 2005, Kleinschmidt-DeMasters et al 2005). A probable explanation for the occurrence of PML is CNS immunodeficiency, because of reduced levels of

T- and B-cells in the CSF of natalizumab-treated patients (Stuve et al 2006), highlighting the complex network of regulation involved in the pathophysiology of MS.

Immunosuppressive drugs are considered as second-line strategy. Mitoxantrone interferes with DNA synthesis and repair, suppressing a variety of cells of the immune system. The major drawbacks about the long-term treatment with mitoxantrone are its cardiotoxicity and a small risk of developing leukaemia, limiting thus the use of such drugs only for a few years. Mitoxantrone appears to reduce the number of relapses and burden of disease on MRI (Neuhaus et al, 2007). Azathioprine, a purine analogue, is a less potent immunosuppressant that has also been shown to reduce relapses in meta-analysis (Yudkin et al., 1991) but since it is an old drug large-scale modern trials have not been conducted.

2. EPIDEMIOLOGY

2.1 INCIDENCE AND PREVALENCE

MS has an uneven geographical distribution which is seen on a regional and world scale. The cause for such peculiar distribution has been debated for long time, invoking both genetic and environmental factors. Genetic predisposition cannot explain alone the remarkable differences observed in the geographical variations but the search for putative environmental culprits has not produced definitive results. The current view is that, although there might be independent additive risk factors, susceptibility is mediated by direct interactions between the environment and genes.

MS is rare in Asia and, on a world scale, it is rare in the tropical and subtropical belts. Within regions of temperate climate, MS incidence and prevalence increase with the latitude, both north and south of the equator (Kurtzke, 1995). MS is most common in populations of Northern European descent with a prevalence of approximately 100 per 100,000 (Compston 1997). The highest prevalence has been observed in Northeast Scotland and Orkney Island (population ca 17,000), where a rate of over 200/100,000 has been described in the 1970s (Poskanzer et al 1980). These figures included also clinically probable cases. The prevalence figures in Orkneys appear to be even higher today (James Wilson, personal communication). In Kyrönmaa in western Finland (population 100,000) a prevalence of 219/100,000 has been found for clinically definite MS (Tienari et al, 2004). In Mediterranean countries the prevalence rate significantly decreases with the notable exception of Sardinia (Rosati et al 1987). The European north-south gradient is observed also in the United States where an additional east-west gradient is present, reflecting the possible role of Scandinavian immigration (Bulman and Ebers 1992). In Australia the region of high prevalence correlates with the presence of Caucasian population (Hammond et al 1988) even though theories explaining the geographical distribution of MS on a world scale by genetic clines seem unlikely (Poser 1994). In other ethnic groups MS is much rarer when compared to the prevalence in Caucasoids (Kurtzke 1983b).

In Finland the prevalence of MS follows an uneven geographical distribution with a high-risk area situated in the Southern Ostrobothnia region Kyrönmaa (Figure 2) where a steady increase in incidence and a prevalence rate of over 200/100,000 have been reported (Sumelahti 2001; Tienari et al, 2004). The exceptional familial clustering of cases observed in this region

(Wikstöm 1975) together with specific predisposing haplotype signatures suggest the contribution of a genetic founder effect to the high frequency of MS (Pihlaja et al, 2003; Tienari et al, 2004; Kallio et al, 2009).

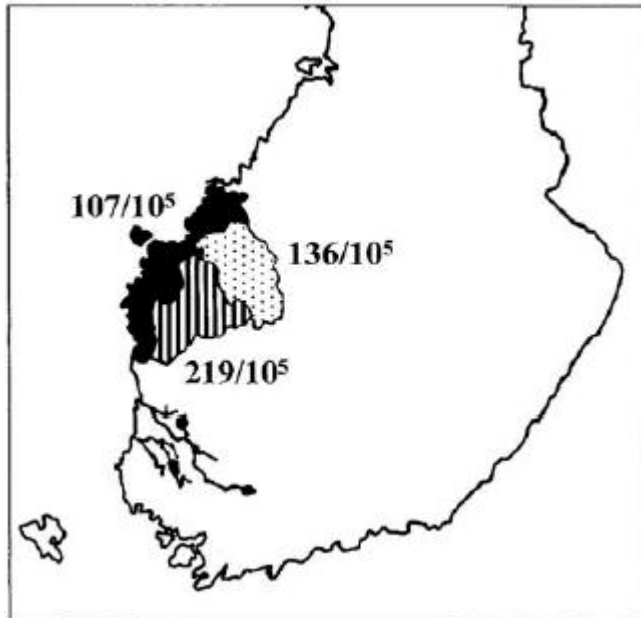

Figure 2 – The uneven geographical distribution of MS prevalence in Finland. Vaasa region (depicted in black): $107/10^5$ (CI 90-124). Seinäjoki north (depicted in white with dots): $136/10^5$ (CI 108-164). Seinäjoki south (depicted in with vertical lines): $219/10^5$ (CI 190-247). Picture modified Tienari et al (2004).

2.2 MIGRATION STUDIES

Migration studies have given important insight for the role of environment in the risk of developing MS. The incidence of the disease in migrants seems to be intermediate between that of their birthplace and that of their new residence. If the migration occurs early in childhood (before the age 15) then the risk tends to be closer to that of the final residence (Gale 1995). In the UK the risk of MS in migrants from India increases in the second generation, mirroring the possibility of early exposure to environmental risk factors even though selection processes affecting the migrant population cannot be excluded (Elian 1990).

3. ENVIRONMENT AND MS

MS is considered to be a multifactorial disease where both environment and genetics play an important role in its pathogenesis. Previous studies have provided good evidence that environmental factors play a role in the uneven geographical distribution of MS. The search for the environmental trigger has focused mainly on two aspects, possible infectious agents or the latitude-related photobiology (i.e. sunlight exposure and vitamin D deficiency) as determinants of the MS risk.

3.1 INFECTIOUS AGENTS

Some viruses are known to induce demyelinating disease in humans and experimental animals. In humans acute viral infections such as measles, chicken pox and rubella may cause post-infectious complications like encephalomyelitis. One example is subacute sclerosing panencephalitis, a rare chronic, progressive encephalitis caused by a persistent infection of immune resistant measles virus. There are disorders such as tropical spastic paraparesis and Human T-cell Lymphotropic Virus (HTLV)-associated myelopathy that have an MS-like disease course and both are caused by the retrovirus HTLV-1. In animals Visna-Maedi virus and Theiler's murine encephalomyelitis virus can mediate demyelinating diseases in sheep and mice respectively. Many viruses and other microbial agents have been suspected as etiological agents but their role in MS pathogenesis is not yet completely understood.

3.1.1 VIRUSES

In order to link the association of viral infection with the etiology and pathogenesis of MS, three main hypotheses have been formulated explaining the mechanism of the possible interaction.

1. The first hypothesis postulates that molecular mimicry between viral antigen and MBP or other myelin antigens induces autoimmunity in genetically susceptible individuals (Fujinami and Oldstone 1985, Wucherpfennig et al 1995).
2. The second hypothesis is that infection of a virus during childhood could establish a latent infection in the central nervous system (CNS) and reactivation of the latent virus could lead to the damage of the oligodendrocytes (Challoner et al 1995).
3. The last hypothesis presupposes that viral infection may be an epiphenomenon that indirectly exacerbates the disease course and lesion development (Panitch 1994).

Since 1960s a number of viral candidates has been proposed but the majority of them has failed to stand the test of time. The most promising etiological candidate is the Epstein-Barr virus (EBV),

a very common infectious agent in humans. Proposed as possible causative agent almost thirty years ago (Warner and Carp 1981), EBV has been strongly associated with MS since nearly all MS cases have been infected by the virus compared with 90% of healthy people (Ascherio and Munger 2007). In a prospective case-control study performed on two cohorts of US nurses, Ascherio and co-workers (2001) examined the association between serum anti-EBV antibody titers and risk of developing MS. Before disease onset, cases who subsequently developed MS had significantly higher anti-EBV antibody levels when compared to their matched controls. Furthermore, based on recent meta-analysis there is a 2.3-fold risk in developing MS if the subject has been infected with EBV in late childhood or adulthood (Ascherio and Munger 2007) and MS patients showed a significant increase in antibodies directed against EBV in the CSF (Bray et al 1992). Quite recently Serafini and colleagues (2007) provided the first pieces of evidence that a proportion of B-cells infiltrating the CNS are infected with EBV.

Another interesting candidate is human herpes virus 6 (HHV-6), a neurotropic virus present in post-mortem MS lesions (Challoner et al 1995). Because of its ubiquitous prevalence and uniform early age of infection it has been impossible to compare the MS risk for infected versus non-infected individuals, but immunological and molecular studies have showed an increase in markers of HHV-6 infection in blood cells or CSF of MS cases (Sola et al 1993, Soldan et al 1997). A possible gene-environmental interaction has been reported between active replication of HHV-6A and Major Histocompatibility Complex Trans-Activator 2A (MHC2TA) gene (Alvarez-Lafuente et al 2009).

In late 1990s Perron and colleagues partially characterized from blood and CSF of MS patients a novel retrovirus, MS-associated retrovirus (MSRV), previously known as LM7 (Perron et al, 1997). Complete MSRV sequence revealed a related new family of human endogenous retroviruses (HERVs), retroviral agents derived from past infections in human evolutionary history (Komurian-Pradel et al, 1999). The family was named HERV-W from tryptophan t-RNA binding site. Recently HERV-W has been shown to be expressed in the brain and activated in MS patients (Mameli et al 2007). However further evidence is needed to elucidate the role played by HHV-6 and MSRV in MS pathogenesis.

3.1.2 BACTERIA

Even though common microbial infections are associated with the relapses, bacteria have been overlooked as etiological agents of MS. Wucherpfennig and Strominger (1995) have shown that both viruses and bacteria contain homologous peptide epitopes that are able to activate MBP primed T-lymphocytes. In the past *Chlamydia pneumoniae* nucleic acid has been found in the CSF of MS patients (Sriram et al 1998) but, after initial enthusiasm, other researchers failed to confirm the original results (Kaufman et al, 2002). Intriguingly non-pathogenic gut bacterial proteins possess the potential to act as autoimmune immunogen mimics (Westall 2006) and a microbial peptide, common to several bacterial classes, can induce MS-like disease in transgenic mice with a human leukocyte antigen (HLA) DRB1*1501 and a human T-cell receptor (TCR) recognizing MBP (Harkiolaki et al 2009). It is of interest that, at least in mice, the MHC alleles (that modulate the risk to multiple autoimmune or immune-mediated disorders) also seem to modulate the composition of gut bacterial flora (Toivanen et al, 2001). However, there has not been much research activity studying these connections.

3.2 SUNLIGHT AND VITAMIN D

There is a well-known association between MS and latitude, which intuitively correlates with duration and intensity of sunlight. Nearly fifty years ago Acheson and colleagues (1960) pointed to the role of sun exposure in MS and later vitamin D and calcium were suggested as possible environmental determinants of the prevalence for MS (Goldberg 1974). In a study conducted in the United States it has been shown that both outdoor work and residence in high sunlight area were protecting from the MS risk (Freedman et al 2000); a report involving 81 monozygotic twin pairs discordant for MS revealed that the affected twins had lower levels of sun exposure during childhood (Islam et al 2006). One of the first observations linking vitamin D intake to MS risk comes from a Norwegian study that reported lower MS prevalence in coastal villages with greater consumption of oily fishes, an excellent source of vitamin D (Westlund 1970). The case-control study of Van der Mei (2003) demonstrated low childhood sun exposure in Australian/Tasmanian MS patients as compared to age, sex, race and geographically matched controls. Multiple measures were used to estimate the magnitude of sun exposure including also measurement of actinic skin damage of the hands, which is an objective cumulative measure of sun exposure.

The beneficial role of vitamin D in MS protection has been further confirmed by longitudinal studies among American nurses and military personnel (Munger et al 2004, 2006). In an animal

model of MS, experimental autoimmune encephalomyelitis (EAE), the injection of vitamin D completely prevented the clinical and pathological signs of disease (Lemire et al 1991) although the molecular mechanisms responsible for these effects are still not clear. Recently a direct functional interaction between vitamin D and major histocompatibility complex (MHC) class II has been suggested (Ramagopalan et al 2009). Sequence analysis revealed a putative vitamin D regulatory element (VDRE) located in the promoter of the HLA DRB1*1501, the main susceptibility allele for MS. The VDRE was able to bind vitamin D and to induce increased expression upon stimulation with 1,25-dihydroxyvitamin D₃. The authors hypothesized that a lack of vitamin D *in utero* or early in childhood could affect central deletion of autoreactive T-cells due to less effective thymic presentation of self-antigens on HLA class II molecules. This finding represents thus far one of the few experimental clues for environment-gene interaction in determining MS risk.

There is evidence for seasonal variation in the determination of MS risk. In Canadian families an increased MS prevalence among people born in May has been observed, whereas a reduced risk of developing MS is found for people born in November (Willer et al, 2005). A similar pattern has been observed also in Finland (Saastamoinen, manuscript in preparation). One speculative explanation for the seasonality would be linked with vitamin D: the higher risk for newborns in May could reflect low maternal and fetal vitamin D levels during the winter (Willer et al, 2005). It is, however, clear that there are many other possible explanations for the observed seasonality.

3.3 OTHER PROPOSED ENVIRONMENTAL RISK FACTORS

Other environmental risk factors have been proposed for MS although the evidence is quite weak. The role of cigarette smoking in MS has recently gained increasing interest. Smoking has been associated with a faster transition from RRMS to SPMS (Hernan et al 2005), whereas significantly increased risk for developing MS was found in female smokers before age of disease onset (Hernan et al 2001). A possible rationale for smoking and MS risk might involve neurotoxic or immunomodulatory effects of components found in cigarettes (Smith et al 1963, Sopori et al 1998). Physical trauma and psychological stress have been proposed as risk factors of MS, but the evidence has been regarded as inconclusive. A vivid debate on this issue was recently witnessed on the pages of *Neurology* (Poser 2000; Chaudhuri et al, 2000; Lehrer 2000, Goodin 2000).

4. MS PATHOGENESIS

Despite many years of intense research we still do not have a definitive model for the initiation and progression of MS. The extensive amount of work performed in the past has provided important insights about the molecular and cellular events that take place in the disease course, although the mechanisms underlying the pathophysiology of MS are not yet completely understood.

In 1948 Elvin Kabat provided the first evidence for the inflammatory nature of the disease with the observation that MS patients have abnormally high titres of oligoclonal immunoglobulin in the CSF (Kabat et al 1948). Before this finding an animal model for MS, EAE, was established with repeated injections of rabbit brain and spinal chord extracts into primates (Rivers et al 1933). At this time, it was not understood that these extracts elicited an autoimmune reaction against myelin, only in late 1940s it was discovered that EAE was an induced autoimmune disease (Morgan, 1947). Later, using a transgenic mouse model (with a T-cell receptor specific for MBP), it has been shown that peripheral activation of myelin-reactive T-cells is required in order to induce CNS inflammation; mice housed in a sterile environment did not develop demyelination (Goverman et al 1993). This finding provides a compelling link between environmental microbes and autoimmunity.

The most established model to date for the pathogenesis of MS suggests that autoreactive T-cell clones specific for myelin antigen become activated in the periphery via molecular mimicry by viral or bacterial proteins (Figure 3). Underlying immunoregulatory defects, such as functional impairment of regulatory T-cells (Tregs), allow further activation of autoreactive T-cells. Increased permeability of the BBB leads to lymphoid cell infiltration into the CNS where the activated myelin-reactive T-cell clones recognize antigen presented by microglia and an inflammatory cascade is initiated. The disease process results in gradual loss of myelin sheath, although spontaneous remyelination occurs in the relapsing-remitting phase, corresponding to the period of the amelioration of the clinical symptoms (remitting phase) in MS patients. However, recurrent inflammatory attacks undermine the myelin repair system leading to reactive gliosis and axonal damage in the later progressive phase of the disease.

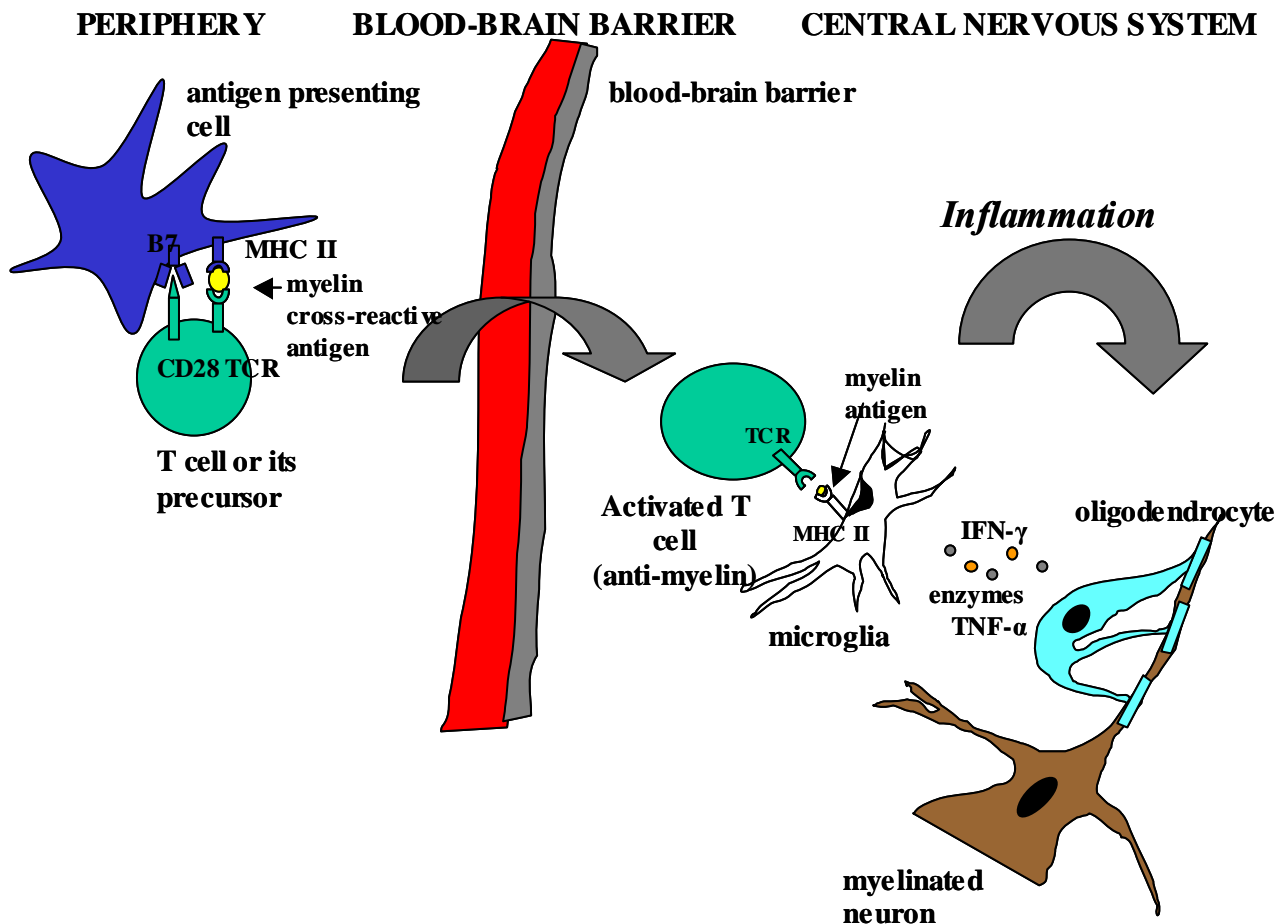

Figure 3. Supposed pathogenesis model for MS for type-I lesion. In Type-II lesion the effector cell penetrating BBB would be B-cell. In Type-III lesion the inflammation would occur at the BBB or vascular wall. In Type-IV lesion the lymphocyte migration does not play such an important role any more, but the myelin-oligodendrocyte unit has become metabolically compromised.

4.1 IMMUNOPATHOPHYSIOLOGY OF MS

Both cell-mediated and humoral immune systems present abnormalities in MS patients, although it has been not trivial to distinguish between phenomena and epiphenomena.

4.1.1 CELL-MEDIATED IMMUNE SYSTEM

Autoreactive T-cells recognizing myelin epitopes are present in the peripheral blood of both MS patients and healthy individuals. Almost twenty years ago it was shown that among T-cells isolated from the blood of MS patients many clones exhibited specificity for MBP p85-99 epitope (Ota et al 1990). More particularly, the T-cell receptor (TCR) for these clones was found to bind the MHC-epitope in an unconventional fashion, with the TCR making primarily contact with the MHC backbone rather than the antigen itself (Hahn et al 2005). Therefore autoreactive

T-cells would have a higher degree of functional degeneracy, as observed in the case of cross-reactivity against other myelin epitopes with MBP-reactive T-cell clones (Ausubel et al 1996). This observation supports the hypothesis that molecular mimicry by viral or bacterial peptides could prime the myelin-reactive T-cells (Wucherpfennig et al 1995). Another challenge to the determination of the immunodominant epitope that initiates MS is a phenomenon known as “epitope spreading”. When injected with a single MBP epitope, genetically susceptible mice develop EAE, generating T-cells directed against the administered peptide (Lehmann et al 1992). During the course of the disease a T-cell population became activated also against other MBP epitopes and when isolated then adoptively transferred into naïve mice, these T-cells specific for cryptic MBP epitopes were sufficient to initiate the disease. This phenomenon seems to happen also in humans since most MS patients exhibit T-cell reactivity to many myelin antigens (Ota et al 1990).

4.1.2 ROLE OF REGULATORY T-CELLS

The presence of potentially autoreactive T-cells in the circulation of healthy individuals indicates that there are additional regulatory mechanisms to clonal deletion in the thymus and anergy in the periphery for the maintenance of immunologic self-tolerance. An important role played by Tregs is in preventing the development of autoimmune disorders by their inhibition of self-antigen-reactive T-cells (Sakaguchi 2000). Often phenotypically classified as $CD4^+CD25^{\text{high}}$, human Tregs are characterized by a very heterogeneous cell population where the most specific marker is the nuclear transcription factor FoxP3, whose expression correlates with their suppressive activity (Wang et al 2007). In patients with autoimmune disorders the autoreactive T-cells have a lower threshold for the activation when compared to healthy controls (Reijonen et al 2002). In MS patients Tregs have lower levels of FoxP3 and this decrease correlated with the Treg loss of function (Huan et al 2005). Furthermore Astier and co-workers (2006) showed that $CD4^+CD25^{\text{high}}$ Tregs isolated from MS cases are normal in frequency but poorly suppress the activation of autoreactive T-cells. Even though the role of functional dysfunction of Tregs in the pathophysiology of MS might be relevant, recently it has been shown in mice that myelin-specific $CD4^+CD25^{\text{high}}$ cells accumulate in the CNS but fail to control autoimmune inflammation (Korn et al 2007).

4.1.3 HUMORAL IMMUNE SYSTEM

Although MS has often been considered predominantly a T-cell mediated disease, the role of B-cells in the pathogenesis has recently been reconsidered. Traditionally B-cells have been

implicated in MS for the production of autoantibodies against myelin and non-myelin antigens. These immunoglobulins can trigger the destruction of the tissue by recruiting macrophages and activating the complement pathway, although their relevance in MS pathogenesis has not yet been clarified. Among the possible pathogenic antigens, the role played by the anti-inflammatory heat-shock protein $\alpha\beta$ -crystallin has gained recent attention (Ousman et al 2007). In fact the production of antibodies directed against $\alpha\beta$ -crystallin could exacerbate the inflammation by the blockage of its immunosuppressive function.

In other autoimmune disorders (rheumatoid arthritis, myasthenia gravis), B-cells aggregate into lymphoid-like structures in the target, similarly to what happens in the meninges of MS patients (Serafini et al 2004). Although restricted to late disease phases, the formation of ectopic immunological follicles in MS patients brains could provide the microenvironment for B-cells maturation and proliferation. Furthermore it has been demonstrated that CXCL13, a chemokine involved in B-cells homing to lymphoid tissues, expression was detected in the intrameningeal follicles and was high in the CSF of MS patients (Serafini et al 2004, Krumbholz et al 2006).

4.2 ROLE OF CNS RESIDENT CELLS

ASTROCYTES. Astrocytes have been referred to as the backbone of the CNS which provide the support for neuronal transmission. In addition, astrocytes foot processes are central in maintenance of the BBB. Moreover, they can act as non professional antigen-presenting cells (APC) and at least in mouse they are able to activate encephalitogenic T-cells through MHC class II (Stuve et al 2002).

MICROGLIA. Microglia are the immune-sentinels of the CNS. They are considered resident macrophages of the brain and spinal chord and act as first and main form of active immune defence. Infiltrating macrophages and activated microglia are the key players in the initiation of tissue damage during the inflammatory events taking place in the CNS. In active MS plaques osteopontin, a protein produced by macrophages and activated microglial cells, is highly expressed and induces a cascade of pro-inflammatory events such as the recruitment of monocytes and the inhibition of T-cells apoptosis in the lesions (Chabas et al 2001, Hur et al 2007). Microglia are important antigen presenting cells that are primed by CD4+ T lymphocytes; once activated they are able to secrete several molecules, such as proteases and cytokines, that may destroy the myelin sheath. However, the activation of microglia and macrophages with subsequent demyelination and tissue damage does not require the induction of the adaptive immune system. Various Toll-like receptors (TLRs) are expressed on both cell populations and

several endogenous ligands for TLRs are locally present. Injection of bacterial lipopolysaccharide (LPS), a ligand for TLRs and important activator of innate immunity, into the white matter results in demyelinating plaques (Felts et al 2005), whereas precipitated fibrin, a ligand for TLR4, has been found on the surface of microglial cells and macrophages in active MS lesions and LPS-induced inflammation (Marik et al 2007).

4.3 MYELIN AND MYELINATION

Myelin wrapped around the axons enables rapid saltatory conduction of action potentials and contributes to the maintenance of axonal integrity (Nave et al, 2008). In the CNS myelination is carried out by oligodendrocytes. In MS, demyelination is the pathological process in which myelin sheaths are lost as a consequence of insults targeted at oligodendrocytes. Until recently it was believed that the remyelination process took place only in the active lesions and was practically absent in chronically established plaques. The failure of myelin repair has been attributed to the impairment of mature oligodendrocytes generation or their inability to myelinate the lesions. Lately two studies have showed that in a subset of MS patients there is evidence of ongoing remyelination at late phases (Patrikios et al 2006, Patani et al 2007). The reason for such heterogeneity in MS patients population is not clear but it seems that the amount of remyelination correlates positively either with the older age at death of patients or longer duration of the disease.

Another recent study has described a new molecular mechanism regulating myelination and remyelination in mouse (Mi et al 2007). Inhibiting the function of leucine-rich repeat and Ig-domain-containing, Nogo receptor-interacting protein (LINGO-1) stimulates myelin formation and prevents progressive axonal damage in chronic EAE. This finding revealed a new pathway involved in the remyelination process and a potentially interesting target for human therapeutic applications.

Finally, there has been recent interest about the possible role played by steroid hormones, especially sex hormones, in the remyelination process. The rationale for it is that remission of MS symptoms is seen during pregnancy, in particular during the last trimester when estrogens and progesterone plasma levels are at their maximum (Confavreux et al, 1998; Houtchens 2007). When estriol and progesterone pellets were implanted in mice during the effector phase of adoptive EAE, only estriol treatment reduced the severity of EAE significantly compared with placebo, whereas progesterone treatment had no effect (Kim et al, 1999). However, progesterone

given prior to EAE induction showed a clinical benefit and produced myelinating and neuroprotective effects (Garay et al, 2008). Furthermore combined estradiol plus progesterone therapy more effectively prevented neurological deficits.

5. GENETICS OF MS

MS is defined as complex genetic disorder where several genes are thought to play a role in the susceptibility to the disease. A number of loci each contribute a relatively small effect, with no one locus being either necessary or sufficient, and interactions with environment further increase complexity. Unlike Mendelian traits, where a single gene causes the disease, complex traits are characterized by a weaker correspondence between the presence of a predisposing genotype at a single genetic locus and the phenotypic outcome. This is explained by the concept of predisposition, for which a gene does not directly cause the disease but rather confers susceptibility to it. A consequence of this phenomenon is that not all the carriers of the disease gene will develop the disease because of the low penetrance of the variant. Evidences for genetic contribution to MS have arisen during the last thirty years from several studies such as racial differences in the recurrence risk, familial clustering of MS cases, twin and other genetic analyses.

5.1 FAMILY AND TWIN STUDIES

Approximately 10% of MS cases have a family history of MS, but large extended pedigrees are uncommon, with most of MS families having no more than two or three affected individuals (Willer et al 2007). Even though no clear mode of inheritance can be inferred from segregation analysis (Compston et al 2006), several population-based studies of familial recurrence risk have provided an estimate of the increased risk for MS in the relatives of patients (Sadovnick et al 1998; Robertson et al 1996; Carton et al 1997). This familial clustering can be quantified with λ_s , the ratio of the risk of disease in siblings of an affected individual compared with the general population; in the case of MS the ratio equals to approximately 15 (Sawcer 2006), a relatively high value when compared to more common disorders such as asthma and hypertension (for these conditions the sibling recurrence risk ratio is around 3 and 4, respectively). Other family-based analyses such as adoptees (Ebers et al 1995), conjugal pairs (Robertson et al 1997) and half-siblings (Ebers et al 2004) studies have highlighted the crucial role of genetic relatedness in the risk of developing the disease.

Twin studies have been fundamental in separating genetic and environmental effects on MS susceptibility. A significantly higher concordance rate in monozygotic (MZ) twins as compared to dizygotic (DZ) twins has been replicated in several cohorts (Ebers et al 1986, Kinnunen et al

1987, Sadovnick et al 1993, Mumford et al 1994, Thorpe et al 1994, Willer et al 2003, Hansen et al 2004, Kuusisto et al, 2008) with the exception of one study (French Research Group on Multiple Sclerosis 1992). When previous studies are pooled together, the concordance in MZ twins is on average 16% while in DZ twins the value reaches 4%, suggesting evidence for genetic factors in MS (table 2). More particularly a MZ:DZ ratio of 4 would imply a single recessive gene underlying MS genetics although we know from segregation analysis this is not the case. Recent observations have indicated the possibility that the concordance rate for MZ twins might be elevated in high prevalence areas, partially explaining the lack of replication of the French study (Ristori et al 2006, Islam et al 2006). This implies penetrance in MZ twins living in Mediterranean areas is influenced by non-genetic factors, highlighting the importance of environmental variables at those latitudes (Ristori et al 2006). Although discordance in monozygotic twins is considered as proof of environmental influence, the observed differences in concordance between genetically identical individuals might reflect other phenomena such as microchimerism (Willer CJ et al 2006), stochastic or epigenetic effects (Fraga et al 2005, Kaminsky et al 2009).

REFERENCE	POPULATION	MZ	DZ	MZ:DZ RATIO
		<i>Number of concordant/total (%)</i>	<i>Number of concordant/total (%)</i>	
Ebers et al., 1986	Canada	7/27 (25.9%)	1/43 (2.3%)	11.3
Kinnunen et al., 1987	Finland	1/11 (9.1%)	0/10 (0%)	n.a.
FRGoMS, 1992	France	1/17 (5.9%)	1/37 (2.7%)	2.2
Sadovnick et al., 1993	Canada	8/26 (30.8%)	2/43 (4.7%)	6.7
Mumford et al., 1994	United Kingdom	11/44 (25%)	2/61 (3%)	8.3
Thorpe et al., 1994	United Kingdom	8/23 (34.7%)	1/41 (2.4%)	14.5
Willer et al., 2003	Canada	37/146 (25.3%)	12/224 (5.4%)	4.7
Hansen et al., 2004	Denmark	5/37 (13.5%)	1/171 (0.6%)	22.5
Ristori et al., 2006	Continental Italy	4/51 (7.8%)	3/147 (2%)	3.9
Ristori et al., 2006	Sardinia	1/8 (12.5%)	0/10 (0%)	n.a.
Islam et al., 2006	North America	56/418 (13.4%)	20/380 (5.3%)	2.5
Kuusisto et al., 2008	Finland	3/10 (30%)	2/14 (14.3%)	2.1
Total*		118/724 (16.3%)	41/1044 (3.9%)	4.2

* Only the largest study of a population was included here (to avoid overlap between studies).

Table 2. Previously published MS twin concordance studies.

5.2 STRATEGIES TO IDENTIFY DISEASE GENES

In the last two decades two principal approaches have been used for localizing and subsequently identifying disease genes. 1. Linkage analysis in families with multiple cases. Linkage detection is based on co-segregation of chromosomal marker and the disease, taking advantage of the meiotic events in the pedigrees. 2. Assessment of allelic association, based on linkage disequilibrium between marker allele and disease allele, using either case-control or family-based settings. This approach exploits the historical recombination that took place in the ascertained population.

5.2.1 LINKAGE ANALYSIS

Linkage analysis investigates the co-inheritance of a marker locus and a disease locus, identifying discrete segments of chromosomes that deviate from independent segregation and therefore co-segregate with the disease in extended pedigrees. Linkage studies take advantage of the fact that during meiosis each chromosome pairs with its partner (homologous chromosome) and exchange genetic material: this exchange is termed recombination and is the basis for detecting linkage. If two loci are in close proximity on a chromosome then the chance for recombination would be small. If they are far apart on the chromosome then the chance that they would recombine is greater. The frequency of recombination is measured in centiMorgans (cMs), with 1 cM equivalent to the frequency of 1% recombination. During few generations there is very little recombination, thus chromosomal segments of several cMs are shared between parents and offspring (and between siblings as well). Since linkage studies analyze the co-segregation of a marker locus with the disease or trait of interest, in case of linkage the distance between the linked markers and disease locus may be typically quite large (10-20 cMs).

In standard linkage analysis the statistical significance is measured in terms of a lod score that is the logarithm to the base 10 of the odds for or against linkage (free recombination between marker and disease locus). In other words the lod score calculates the overall likelihood of the data by comparing the two alternative hypotheses: a lod score of 3 is considered as statistically significant and indicates that the observed data is 1000 times more likely if there is a disease-linked gene in the region than if there is no disease gene in the region. This method requires the collection of pedigrees with more than one affected member. Traditionally, a few large pedigrees are considered more powerful in mapping the disease locus than several small pedigrees (Ott 1991).

The linkage analysis has proven to be very successful in identifying genes responsible for monogenic disorders but not so effective for complex diseases with the exception of some early encouraging finding such as the involvement of a locus on chromosome 16 in Crohn's disease susceptibility (Hugot et al, 1996; Cavanaugh et al, 2001), which led to the identification of NOD2-mutations (Ogura et al, 2001).

In MS more than 30 datasets have been screened for linkage with different levels of resolution and genome coverage (Fernald et al 2005). Every study has suggested the involvement of different chromosomal regions with MS susceptibility but only the MHC region on chromosome 6p21.3 has repeatedly reached and robustly exceeded the threshold for statistical significance. Other regions have reached the threshold for suggestive linkage (LOD between 2 and 3): 1q, 9q and 16p (Kenealy et al 2004), 2q27 and 5p15 (Dyment et al 2004), 5p (Dyment et al 2004, Kuokkanen et al 1997), 5q33 (Sawcer et al 2005), 17q22-24 (Sawcer et al 2005, Kuokkanen et al 1997) and 19p13 after HLA-conditioned analysis (Sawcer et al 2005). The reason for such limited success lies probably in the design of linkage studies which are underpowered in case of common variants with small relative risk (i.e. relative risk <2) as susceptibility factors for complex disorders (Risch and Merikangas 1996). Another factor affecting the success of linkage is the genetic heterogeneity of the analysed disorder. Particularly locus heterogeneity, i.e. the involvement of different loci in the causation of a disease/phenotype, reduces the power of the lod score test (Morton 1955). Overall, the major utility of the linkage approach has been in setting an upper limit on the expected effect sizes and ruling out the presence of strong effects by individual loci other than the MHC region.

5.2.2 ASSOCIATION STUDIES

Compared to linkage, association studies are more powerful in detecting weak effects exerted by relatively common polymorphisms. Association studies determine whether specific genetic variants (allelic variants) predispose to disease at the population level by comparing the frequency of marker locus alleles in patients and matched controls. If a disorder is found to be associated with a particular marker allele, this may suggest a causal relationship between the marker allele and the disease (i.e. marker allele is the disease predisposing variant, e.g. *APOE* ϵ 4 and Alzheimer's disease, Corder 1993). More often the marker allele "marks" a neighbouring disease allele, a phenomenon termed linkage disequilibrium (LD). LD represents the non-random association between alleles at two linked loci that reflects their vicinity and the

correspondingly low probability of recombination breaking the haplotype on which they are found (Bodmer, 1972). The strength of LD depends, in a given population, on several factors, the most important ones being the number of founding individuals (number of founding haplotypes) and the time since founding (Shifman et al, 2001). With each generation recombination tends to reduce LD, erasing the association between alleles except for markers located in the close proximity of the susceptibility locus. Just as linkage exploits recombination within current families, linkage disequilibrium (i.e. association) studies take advantage of the many recombination events that occurred historically in a population. As a result, association due to linkage disequilibrium occurs over short distances, typically much less than 1 Mb, and therefore association studies are often used to fine-map the disease locus identified from a previous linkage peak.

The major paradigm for case-control association studies in the last years has been the common-disease common-variant (CDCV) hypothesis which assumes that much of the genetic variation of complex common disorder is due to relatively few common variants. The proposed rationale for genotyping common polymorphisms (i.e. variants with a population allele frequency $\geq 5\%$) is that common SNPs can significantly contribute to disease prevalence even if their effect on disease risk is modest (Reich et al, 2001). At the same time an alternative view on the genetic architecture of complex disorders, the rare variant hypothesis, has been proposed. The rare variant hypothesis assumes that susceptibility to common disorders is due to numerous low frequency polymorphisms, each conferring a moderate but detectable increase in relative risk (Bodmer et al, 2008). A comparison of both hypotheses is given in table 3 with emphasis on the main differences between them. Probably both models are correct and not necessarily mutually exclusive as there is evidence for both. It is worth noting that if the rare variant hypothesis is true, association studies have inadequate power to detect causative variants since the multitude of rare alleles (whose overall frequency would be high enough to be responsible for the susceptibility of a common disease) would not be tagged by any marker or haplotype.

Following the recent progress in laboratory techniques, association studies covering the whole genome (genome-wide association studies, GWASs) have become readily available for testing common variation without any assumption about the nature of the genes that influence the disease. In the last two years GWASs have been successful in identifying loci responsible for the susceptibility to complex disorders (Rioux et al 2007, Saxena et al 2007). To date, four GWASs have been performed in MS, (IMSGC 2007, WTCCC 2007, Baranzini et al 2009, ANZgene,

2009) yielding interesting findings. The IMSGC study published a family-based approach using 500,000 SNPs genotype on Affymetrix/Illumina arrays in 931 trios. The most significantly associated SNPs were analyzed in a second dataset of 2931 cases and 4205 controls as well as in pooled material (using a total of 12360 individuals).

The WTCCC used a case-control approach scanning for 14,500 non-synonymous SNPs in 975 MS patients. Although lacking replication this study has partially confirmed some leads from the IMSGC and proposed new susceptibility loci whose role has to be confirmed in other studies. A study from Baranzini et al (2009) has reported the results from a GWAS performed in 1000 well-characterized MS and an equal amount of matched controls. They have compared allele frequencies of over 500000 SNPs in the two cohorts and their influences on several disease-related variables. Recently a GWAS from the Australia and New Zealand MS Genetic Consortium (ANZgene, 2009) has been published. Two independent datasets for a total of 3874 cases and 5723 controls were analysed and several known MS associations were replicated. The results from these studies and their relevance in MS predisposition are discussed in more details in the section 5.4.

<i>CDCV</i>	<i>RARE VARIANTS</i>
Usually detectable with population-based case-control association studies (genome-wide association studies, candidate gene studies)	Usually detectable with DNA sequencing of candidate genes in selected patients
Usually risk allele frequency > 10%*	Risk allele frequency < 5%*
Variants are shared by most human populations	Population-specific variants
OR < 2*	OR ≥ 2*
The impact of the variant on the function is not often obvious	Variants more often have structural effect on protein function, help in understanding disease etiology
<i>Examples:</i> APOE ε4 in Atherosclerosis ¹ and Alzheimer's disease ² PPARG in type-2 diabetes mellitus ³	<i>Examples:</i> NOD2 in Crohn's disease ⁴ ABCA1 in atherosclerosis ⁵

* These are estimates, the exact values cannot be defined.

¹ van Bockxmeer and Mamotte 1992. ² Corder et al 1993. ³ Altshuler et al 2000. ⁴ Lesage et al 2002. ⁵ Cohen et al 2004.

Table 3. Comparison of the two main hypotheses regarding the genetic architecture of common disorders.

5.2.3 ROLE OF GENETIC ISOLATES

Genetic isolates have significantly contributed in the identification of genes for rare Mendelian disorders. The peculiarities of such populations have appealed to geneticists over time and in recent years there has been some discussion about their role in mapping complex diseases (Peltonen et al, 2000). Population isolates, like the Finns, exhibit significantly less genetic diversity at chromosomal and mitochondrial DNA level (Sajantila et al,1996; Kittles et al, 1998). A consequence of that is the increased signal-to-noise ratio: etiologic homogeneity of common diseases (i.e. allelic and locus heterogeneity) increases the chances of detecting a significant signal. In genetic isolates the genetically homogenous population allows the detection of novel associations with a relatively small amount of patients. Furthermore cultural and environmental homogeneity in such genetically homogenous populations decreases the effect of penetrance and phenocopies in the manifestation of complex diseases.

One example has been the discovery of the role of MBP in MS susceptibility in the Southern Ostrobothnian isolate (Pihlaja et al, 2003). Furthermore LD of markers with rare disease alleles extends over greater distances in young population isolates and enables one to use fewer markers in an association study. Recently Sabatti and colleagues have identified a rare variant (minor allele frequency = 0.017) of the gene on chromosome X in part responsible for sex-specific dyslipidaemias. The study was carried out in a selected sample material (Northern Finnish Birth Cohort 1966), pointing out the possible importance of GWAS in the discovery of infrequent variants when carried out in individuals sharing distant ancestors.

5.3 ROLE OF HLA GENES

Several linkage and association studies have pinpointed the role of chromosomal region 6p21.3 as the major player in MS susceptibility. More particularly the genetic signal maps to a wide area spanning the HLA gene complex which includes many proteins associated with immune functions (Figure 4). There are two major classes of HLA genes encoding for highly polymorphic heterodimeric glycoproteins involved in the immune recognition of self from non-self. The telomeric distal region contains class I genes (HLA-A,-B,-C) whereas in the proximal centromeric segments are present the class II genes (HLA-DR,-DQ,-DP). While both α and β chains of the class II proteins are encoded by the MHC region, only the α chain of the class I is encoded by HLA, with the non-polymorphic β 2-microglobulin (the β chain of the class I protein) being encoded on chromosome 15. A third group of genes, generally known as class III and positioned between the class I and II region, encodes for e.g. complement proteins, tumor

necrosis factor and heat shock proteins. The HLA complex is characterized for its high levels of polymorphic variation and the extent of non-random association between alleles in the region (Horton et al 2004).

Initially the association between HLA and MS was reported with the class I region (Naito et al 1972, Jersild et al 1972) and subsequently also with class II (Jersild et al 1973); rather quickly it was established that these observations were not independent associations but the result of the strength of the LD present among alleles of different loci on the same haplotype, with the association primarily deriving from the class II region (Compston et al 1976, Terasaki et al 1976).

Using the modern nomenclature, it was clear that the association signal was segregating with the extended haplotype HLA-DQB1*0602, HLA-DQA1*0102, HLA-DRB1*1501 but the fine-mapping of the susceptibility locus has been complicated by the extensive LD between DRB1 and DQB1. Using a MS cohort of African-American ancestry where the LD pattern is less intense, a selective association with HLA-DRB1 independent of DQB1 was reported (Oksenberg et al 2004), providing evidence for a primary role of this locus in MS predisposition. Subsequently, Yeo et al (2007) have replicated this finding in a large dataset of European patients but the functional role of HLA-DRB1 gene regarding MS susceptibility still remains elusive. Structural studies have indicated that HLA-DRB1*1501 can bind with high-affinity a peptide deriving from MBP, one of the most studied putative autoantigens (Smith et al 1998).

In the study of Oksenberg and colleagues (2004) HLA-DRB1*1501 was not the only allele that associated with the disease. Since this variant has low frequency in Africa the analysis provided also a role for HLA-DRB1*1503 and HLA-DRB1*0301 alleles. It is now clear that the risk carried by HLA-DRB1*1501 allele may be modified depending on which MHC haplotype is present in the heterozygous state (Dyment et al 2005, Barcellos et al 2006, Ramagopalan et al 2007). Also a role for the existence of an independent signal from class I region has been proposed in several studies but the extent of LD in the region has complicated its dissection (Marrosu et al 2001, Rubio et al 2002, Yeo et al 2007). A modifier gene has been suggested to be located in the class I region (Friese et al 2008) and in the HLA-DRB5 (Etzensperger et al 2008).

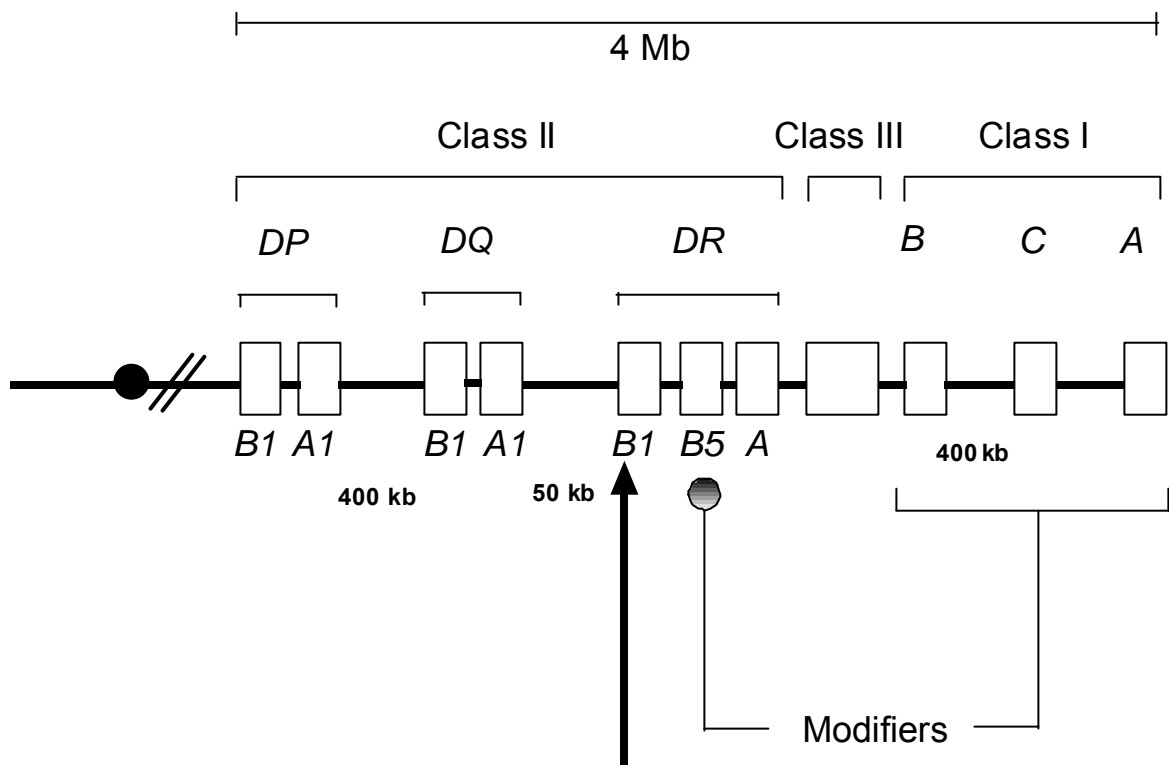

Figure 4. Genomic organization of the HLA complex. The arrow indicates the primary role played by HLA-DRB1 gene in MS susceptibility.

5.4 ROLE OF NON-HLA GENES

The MHC region alone explains only a portion, approximately less than half, of the heritability of MS. In the last few years the GWAS and other studies have shed some light into the genetic architecture that lies behind the susceptibility to MS, producing of list of genes whose association with the disease has been replicated in more than one dataset (Table 4). Below I discuss in more detail the most significant loci associated with MS and their possible involvement in the disease pathogenesis.

<i>LOCUS</i>	<i>CHROMOSOME</i>	<i>ASSOCIATED COHORTS</i>	<i>FUNCTION</i>
IL-7R	5p13	UK, US, multiple	Immunological
IL-2RA	10p15-14	UK, US, Canadian, multiple	Immunological
PRKCA	17q22-24	UK, Finnish, Canadian	Immunological
TYK2	19p13	meta-analysis	Immunological
CD58	1p13	meta-analysis	Immunological
EVI5/RPL5	1p22	Dutch inbred, Canadian	Immunological?
KIF1B	1p36	Dutch inbred and outbred, Canadian	Neurological (axonal transport)
CLEC16A	16p13	IMSGC, Sardinia	Immunological
IRF5	7q32	Spanish, Swedish, Finnish	Immunological
CD226	18q22	UK, US, IMSGC	Immunological
MBP	18q23	Finnish, Russian, Italian, multiple	Myelination
IRF8	16q24	meta-analysis	Immunological
CD6	11q13	meta-analysis	Immunological
C7-FLJ40243	5p13	Finnish isolate, Finnish, Sweden and others	Immunological
TNFRSR1A	12p13	meta-analysis	Immunological

Table 4. Non-HLA genes implicated in MS susceptibility on the basis of genetic analysis in more than one population. Multiple = the locus has been associated with MS in three or more populations. Meta-analysis = genome-wide significant evidence of association in a meta-analysis of several populations.

5.4.1 *IL-7R*

Already studied as a candidate gene (Teutsch et al 2003, Zhang et al 2005), the role of the interleukin-7 receptor (*IL-7R*) in MS susceptibility has been unequivocally confirmed by two simultaneous independent analyses (Gregory et al 2007, Lundmark et al 2007) which have shown an association with the SNP rs6897932. The associated polymorphism (a non-synonymous variation, T244I) is situated in the alternatively spliced exon 6 of the gene that encodes for the transmembrane domain. If exon 6 is included then the transcript encodes for a membrane receptor whereas if it is skipped then the mature protein will be a soluble receptor

(Gregory et al 2007). The associated variant increases the proportion of soluble receptor in the bloodstream and therefore is predicted to affect the IL-7R signalling. It is worth noticing that the risk allele is very common, found in 76 % of patients and 72% of controls (IMSGC 2008): carriers of the associated variant have only a 20% increased risk of developing MS (OR = 1.2).

5.4.2 IL-2RA

The IMSGC study has indicated a role for the interleukin-2 receptor alpha subunit (IL-2RA) with two SNPs in moderate LD with each other associating with MS. This finding has been replicated in an independent Canadian cohort (Ramagopalan et al 2007) and it strongly points toward the importance of the IL-2 pathway in MS susceptibility. It is important to notice that these findings are in line with earlier results obtained in type-1 diabetes, rheumatoid arthritis and Graves disease, suggesting a possible common pathogenetic mechanism underlying autoimmunity. Furthermore the relative risk attributable to variation in both IL7R and IL-2RA (OR = 1.2; IMSGC 2008) is very low and explains only a little part of the variance in the risk of MS.

5.4.3 OTHER GENES

Protein kinase C alpha (PRKCA) gene is located on chromosome 17q22-24, a region that has revealed indicative linkage in Finnish MS pedigrees (Kuokkanen et al 1997). A role for PRKCA in MS susceptibility has been further suggested by association study in a UK patient population (Barton et al 2004). Subsequently a LD-mapping study in both Finnish and Canadian MS families confirmed the presence of multiple signals within the PRKCA locus (Saarela et al 2006). Although the SNPs associated with MS were different in the two populations, the risk haplotypes covered the same genomic region, stretching from intron 3 to intron 8. Expression analysis revealed a weak genotype-phenotype correlation in CD4⁺ cells, with lower levels of PRKCA in individual possessing two copies of the risk haplotype. PRKCA has been implicated in T-cell activation for its involvement in the regulation of the IL-2 pathway, suggesting a possible dysregulation of the signal transduction in MS.

Hoppenbrouwers and colleagues (2008) have verified the risk contribution of the best associated SNPs from the IMSGC study (2007) in MS patients from a Dutch genetically isolated population. Apart from a HLA-DRB1 SNP, two polymorphisms in the EVI5 (ecotropic viral integration site 5) gene were confirmed as risk variants and were also replicated in an independent Canadian cohort of MS patients. EVI5 is a common site for retroviral integration

and it could possibly link the involvement of retroviral elements to MS pathogenesis; it is not clear though if the causative variant lies within *EVI5* or its neighbouring genes, such as *RPL5* (ribosomal protein L5).

Kinesin family member 1B (*KIF1B*) has been initially associated in a GWAS performed on the same genetically isolated Dutch population and subsequently replicated in an outbred Dutch and Canadian trio families (Aulchenko et al 2008). The locus encodes for a member of the kinesin superfamily and is believed to be involved in the axonal transport of mitochondria and synaptic vesicle (Nangaku et al 1994, Boldogh et al 2007). The most strongly associated SNP (p-values $< 2.5 \times 10^{-10}$) with MS is located in intron 5, although the causative variant is not known. Nevertheless this finding represents a non-immunologically related gene in MS predisposition. Its possible association with MS has not yet been reported in other populations than Dutch and Canadian materials.

The WTCCC study uncovered the possible involvement of tyrosine kinase 2 (*TYK2*) gene in MS pathogenesis. In a replication study, Ban et al (2009) found an association signal of the same marker located in the exon 21 of the gene. The associated SNP encodes for an amino acid change (proline to alanine) in the kinase domain which is predicted to affect the phosphorylation and hence the activity of the protein.

A GWAS suggested a role for *CD58* in MS predisposition (IMSGC, 2007). Following this finding De Jager and co-workers (2009) re-sequenced and fine-mapped the *CD58* locus in case-control approach. The results revealed a SNP significantly associated with protection from MS.

Already associated with type I diabetes, the polymorphism Gly307Ser *CD226* has been found to be associated also with MS (Hafler et al, 2009). The functional impact of the variant on the protein is not clear yet.

A variant located in *CLEC16A* (c-type lectin domain family 16, member A) locus showed suggestive evidence of association with MS in a GWAS (IMSGC 2007). Zoledziewska and colleagues (2009) genotyped another SNP (rs725613) in the same gene but not in LD with the variant in a case-control cohort of MS and type 1 diabetes (T1D) patients. The polymorphism associated at a significant level with both MS and T1D, bringing the evidence for a possibly shared disease pathway.

In a meta-analysis of GWASs for MS three new susceptibility loci were identified with genome-wide significance, $p < 5 \times 10^{-8}$ (De Jager et al, 2009). Two polymorphisms within the tumor necrosis factor receptor superfamily, member 1A (TNFRSF1A) genomic region associated with the disease. One of them (rs1800693) is located in the fourth intron and it is relatively common (allele frequency of 57%) whereas the other polymorphism encodes for an amino acid change, R92Q, and it is found in only 2% of the population. These results link both a common polymorphism of modest effect and a rare variant of stronger effect to MS susceptibility.

Interferon responsive factor 8 (*IRF8*) locus was also associated with MS although the significantly associated variant lies 60 kb from the gene (De Jager et al, 2009). An expression analysis showed no correlation between the SNP and *IRF8* transcript levels and therefore the role of the variant remains unknown.

The other genomic region associated with MS was the *CD6* locus which encodes for a molecule involved in T-cell differentiation and in the regulation of tumor necrosis alpha ($\text{TNF}\alpha$) serum levels (De Jager et al, 2009). The SNPs showing evidence for association with MS locates in the first intron of the gene and might have functional effects together with the variants present in *TNFRSF1A* locus.

Using the genetic isolate of Southern Ostrobothnia Kallio et al (2009) have analysed the previously associated chromosomal region 5p. The haplotype analysis excluded a major role for *IL7R* in MS susceptibility in the sample material, with most of the association signal covering the *C7* locus (complement component 7). The result was replicated in another independent dataset from the isolate and a suggestive association was seen also in other more heterogeneous populations. Furthermore the complement activity significantly correlated with the identified risk haplotype.

MBP is an obvious candidate gene for its potential role as target for immune-mediated mechanisms involved in MS pathogenesis. Evidence for association between the disorder and a short tandem repeat located in the promoter of the gene has been found in linkage and association studies (Tienari et al 1992; Tienari et al 1998). Further association has been reported in Italian, Danish and Italian-Russian studies although the analyses were performed with different markers (Ibsen and Clausen 1996, Guerini et al 2000, Guerini et al 2003). The reason in

the lack of replication among different populations might be due to the geographical restriction of the association between MS and the microsatellite marker utilized in the Finnish study. Pihlaja and colleagues (2003) indeed confirmed the previously reported association only in the high incidence region of Southern Ostrobothnia.

However it is important to stress that case-control studies are prone to false results as a consequence of population stratification. Although different algorithms have been developed to assess the presence of genetic subgroups in mixed populations, the combination of case-control and family-based analyses is the best option to avoid spurious associations. It is also worth noting that several GWAS hits mentioned above (De Jager et al 2008, Hafler 2009, Zoledziwska 2009) have been found only in case-control datasets and hence these findings need further replication also in family-based material.

AIMS OF THE PRESENT STUDY

MS is a complex disorder where both genetic and environmental factors have been implicated but its etiology and pathogenesis still remain poorly understood. The purpose of this study was to investigate the role of chromosomes 2q33, 19q13 and IRF5 in MS.

Three chromosomal regions previously associated with other autoimmune disorders have been analyzed in MS datasets to evaluate their role in the susceptibility to the disease.

(i) The 2q33 region has been extensively studied in respect with its possible role in other autoimmune diseases. In MS the results have been conflicting and primarily focusing on the costimulatory immune regulator CTLA-4. The goal was to perform a two-stage association analysis to investigate the role of this chromosomal region in the pathogenesis of MS.

(ii) The 7q32 region and more particularly the IRF5 gene have been already associated with systemic lupus erythematosus, rheumatoid arthritis and inflammatory bowel disorder. The goal was to investigate whether variation in the IRF5 locus would be associated with another putative autoimmune disorder such as MS.

(iii) The 19q13 region has exhibited clustering of putative predisposing loci in several autoimmune disorders. In MS the situation is presently ambiguous with several reports providing weak evidence for a susceptibility gene. The goal here was to perform an allelic association study in order to obtain evidence of an MS susceptibility locus.

(iv) As a follow-up of (i) we focused on the expression of the inducible T-cell co-stimulator (*ICOS*) gene. The goal was to characterize the transcriptional regulation of the locus with attention to alternatively spliced isoforms.

Since MS is a genetically heterogeneous disease, this study takes advantage of the relative genetic homogeneity of the Finnish population to find some of the MS predisposing genes. The objective of this approach will shed a new light into the pathogenesis of the disease and provide new tools to identify individuals at higher risk for possible preventive strategies.

MATERIALS AND METHODS

1. SUBJECTS AND FAMILIES (I-IV)

All patients had clinically definite or laboratory-supported definite MS according to the Poser criteria. No selection was made as to the disease course, hence there were patients with relapsing-remitting, primarily progressive and secondary progressive course. All samples were taken with oral or written informed consent. The studies were approved by ethical committees of Helsinki University Central Hospital (Decision 46/2002, Dnro 192/E9/02) and collaborative institutes. The study material included:

Study I: 134 and 186 Finnish MS trio families in stage-1 and stage-2 respectively. Linkage analysis was performed in 27 multiplex families MS families. Samples were collected from the University Central Hospitals in Helsinki, Tampere, Kuopio, Oulu and the Central Hospital of Seinäjoki.

Study II: 660 Spanish MS cases and 833 controls (samples were collected from hospitals located in Granada, Malaga and Sevilla), 1166 Swedish MS cases and 1235 controls (samples were collected from Danderyd's Hospital or Karolinska University Hospital in Huddinge or in Solna, all located in the Stockholm County of Sweden), 511 Finnish MS trio families (samples were collected from the University Central Hospitals in Helsinki, Tampere, Kuopio, Oulu and the Central Hospital of Seinäjoki).

Study III: 459 and 323 Finnish MS trio families in dataset-1 and dataset-2 respectively. Samples were collected from the University Central Hospitals in Helsinki, Turku, Tampere, Kuopio, Oulu and the Central Hospital of Seinäjoki.

Study IV: 505 Finnish MS trio families. Samples were collected from the University Central Hospitals in Helsinki, Tampere, Kuopio, Oulu and the Central Hospital of Seinäjoki.

The overlaps between different Finnish study materials in this thesis study are shown in table 5.

<i>Study</i>	<i>Dataset</i>	<i>Cohort-1</i> (<i>N=136</i>)	<i>Cohort-2</i> (<i>N=124</i>)	<i>Cohort-3</i> (<i>N=201</i>)	<i>Cohort-4</i> (<i>N=323</i>)
I	1	134/136 ¹			
I	2			186/201 ¹	
II				201/201	310/323 ¹
III	1	134/136 ¹	124/124	201/201	
III	2				323/323
IV				188/201 ¹	317/323 ¹

Table 5. Overlap between different study populations in the Finnish datasets. ¹ The analysis was performed on samples with enough material left. There was no bias in sample selection.

2. DNA ANALYSIS (I-IV)

DNA was extracted from blood peripheral leukocytes using standard procedures. The genotyping of the samples was performed as illustrated below.

Study I: Two methods were employed in microsatellite genotyping in the association analysis: ABI Prism system with fluorescently labeled primers or autoradiography of the polyacrylamide gels using ³³P- α -dATP in the PCR mixtures. The SNPs were amplified by PCR and genotyped by restriction enzyme digestion followed by agarose gel electrophoresis.

Study II: The SNPs were genotyped using multiplex fluorescent minisequencing (single-base extension) with the SNPstream system (Beckman Coulter). The CGGGG indel was amplified by PCR using fluorescent primers with subsequent fragment analysis on an ABI PRISM® 3730 DNA Analyzer.

Study III: Microsatellites were genotyped by autoradiography of the polyacrylamide gels using ³³P- α -dATP in the PCR mixtures. The SNPs were amplified by PCR and genotyped by restriction enzyme digestion followed by agarose gel electrophoresis or by solid-phase minisequencing.

Study IV: Genotyping for 17 SNPs was performed using Sequenom MALDI-TOF mass spectrometry (MassArray Compact Analyzer; Sequenom Inc, San Diego, CA, USA) based on matrix-assisted laser desorption/ionization–time of flight technology and primer extension chemistry. The remaining SNPs were amplified by PCR and genotyped by restriction enzyme digestion followed by agarose gel electrophoresis or by solid-phase minisequencing.

3. STATISTICAL ANALYSES (I-IV)

The statistical analyses were performed as follows:

Study I: Transmission disequilibrium test (TDT) was used to perform allelic association analysis. The genotype data was tested using the TRANSMIT 2.5.2 computer program package. Two-point linkage analysis was performed with the MLINK program of the LINKAGE package.

Study II: The PLINK software was used to compare the allele counts in cases and controls by Fisher's exact test, to calculate odds ratios and also to perform the sliding window haplotype association analysis. The Haploview v.3.3. software was used to determine linkage disequilibrium (LD) between the polymorphisms. In the family cohort, the genotype data was analyzed using the TRANSMIT 2.5.2. computer program package.

Study III: TDT was performed on family material as illustrated in study I. In case-control association analysis the haplotype frequency estimation was performed using the expectation-maximisation algorithm as implemented in the HAPLO program.

Study IV: TDT was performed as illustrated in study I.

4. ELECTROPHORETIC MOBILITY SHIFT ASSAY (II)

Biotinylated and unlabelled double stranded DNA probes were generated for each allele of the polymorphism. The labelled probe was incubated for 20 minutes with a nuclear extract prepared from blood cells. Competition assays were performed with a 100-fold molar excess of unlabelled probe. The binding reactions were run on 6% polyacrylamide gel electrophoresis and transferred to nylon membranes. The biotinylated bands were detected using a chemiluminescent procedure.

5. PROXIMITY LIGATION ASSAY (II)

Polyclonal antibody against SP1 was biotinylated, diluted in a saline buffer and then combined with a streptavidin-oligonucleotide conjugate. Partially double stranded DNA probes were incubated with Jurkat nuclear extract for 30 minutes at room temperature. Anti-SP1-DNA conjugate was added to the mixture and incubated for 2 hours at 20°C. After the incubations ligation and PCR detection were performed.

6. CELL CULTURE AND T-CELL ACTIVATION (IV)

African green monkey kidney Cos-7 cells were grown in Dulbecco's modified Eagle's medium (DMEM; BioWhittaker) supplemented with 10% FCS. Human primary lymphocytes and Jurkat E6-1 were cultured in RPMI 1640 with 2mM glutamine supplemented with 10% FCS.

In order to purify CD4⁺ T-cells, blood samples (40 ml) were obtained from healthy donors and placed into BD Vacutainer CPT tubes (Becton Dickinson, Franklin Lakes, NJ, USA). Peripheral blood cells were pelleted at 1800 xg for 30 minutes. The supernatant representing the mononuclear fraction was washed twice in phosphate-buffered saline solution (PBS) subsequently used for lymphocytes isolation.

CD4⁺ T-cell purification was performed utilizing a magnetic cell separation strategy. Untouched T-cells were isolated from peripheral leukocytes fraction with Pan T-cell Isolation Kit II (Miltenyi Biotech) according to manufacturer's instructions. CD4⁺ T-cells were then further purified by depleting the CD8⁺ fraction with CD8 MicroBeads (Miltenyi Biotech).

For the activation of lymphocytes, 10⁶ cells were incubated for 6 h with phorbol myristyl acetate (PMA) 30ng/ml and ionomycin 300ng/ml and subsequently harvested for the suitable assay.

7. RNA EXTRACTION AND REVERSE TRANSCRIPTASE POLYMERASE CHAIN REACTION (RT PCR) (IV)

Total RNA was purified from peripheral leukocytes with the Rneasy Mini Kit (Qiagen) according to the manufacturer's instructions. cDNA was synthesized from total RNA using M-MLV polymerase according to the manufacturer's instructions, with random RNA hexamer primers (Promega). Subsequently cDNA was used as template for PCR reaction and PCR products were resolved with 2% agarose gel.

8. EXPRESSION VECTORS (IV)

The Δex2-ICOS and the ICOS expression vectors were obtained by respectively amplifying Δex2-ICOS and ICOS coding regions from mRNA of healthy donors' peripheral leukocytes. PCR products were gel-purified and subcloned into pCMV plasmid. The green fluorescent protein (GFP)-Δex2-ICOS and GFP-ICOS expression vectors were obtained by subcloning respectively Δex2-ICOS and ICOS coding regions into pEGFP-N1 (Clontech). All clones were verified by sequence analysis.

9. TRANSFECTION AND CELL LOCALIZATION (IV)

A round glass coverslip was placed in each well of a 6-well plate. COS-7 cells were then seeded at 45% cell confluency on the coverslips in 1 ml of culture medium. After 24 h 4 μg of green fluorescent protein (GFP)-expressing vectors were mixed with Lipofectamine 2000 (Invitrogen,

Carlsbad, CA, USA) according to the manufacturer's instructions. After 24 h the cells were stained with ER-tracker Red (Molecular Probes), Hoechst (Molecular Probes) and subsequently fixed for 10 minutes with 4% paraformaldehyde.

10. GEL ELECTROPHORESIS AND WESTERN BLOTTING (IV)

In order to obtain whole cell extracts, human primary lymphocytes and Jurkat E6-1 were pelleted at 800 xg for 5 minutes. The cell pellets were suspended and washed once in PBS. The cell pellet was subsequently resuspended in CHAPS 1% in PBS, supplemented with protease inhibitors (Complete Protease inhibitor, Roche, Basel, Switzerland), incubated at 4 °C for 30 minutes and centrifuges at 16,600 xg for 20 minutes at 4 °C. The supernatant ("whole cell extracts") was used immediately for protein quantification and protein detection or stored at -80 °C.

Whole cell extracts were resolved by SDS-PAGE on 12% Tris-glycine gels. Proteins were blotted to nitrocellulose with a semi-dry transfer apparatus with 25mM Tris, 190mM glycine and 20% methanol. Membranes were blocked for 1 h at room temperature in 5% milk in TBST (20mM Tris, 140mM NaCl, 0,1% Tween) and incubated with primary antibody (sc-25585, Santa Cruz Biotechnology, Santa Cruz, CA; 1:200 dilution) overnight at 4°C. After washing in TBST, membranes were incubated with horseradish-peroxidase-conjugated secondary antibodies (1:10,000 dilution) for 1h at room temperature. Chemiluminescent detection was performed using ECL Plus on X-Omat AR films.

RESULTS AND DISCUSSION

1. CHROMOSOME 2q33 AND MS

Chromosome 2q33 has been implicated in the predisposition of several immune-mediated disorders. Most studies have focused on the role of Cytotoxic T Lymphocyte Associated 4 (*CTLA4*) gene, which encodes for a protein involved in co-stimulatory down-regulation of immune responses.

A two-stage study was performed to analyse the association of polymorphisms of chromosome 2q33 with MS. Stage-1 served for setting the hypothesis to be tested in stage-2. In all 17 markers, both SNPs and microsatellites, were genotyped (figure 5). Two independent association signals were detected, one with the SNP marker rs3977 and the other with the microsatellite d2s1271. Both signals were obtained outside of the *CTLA-4* locus and therefore we could not find any support for its candidacy in MS susceptibility.

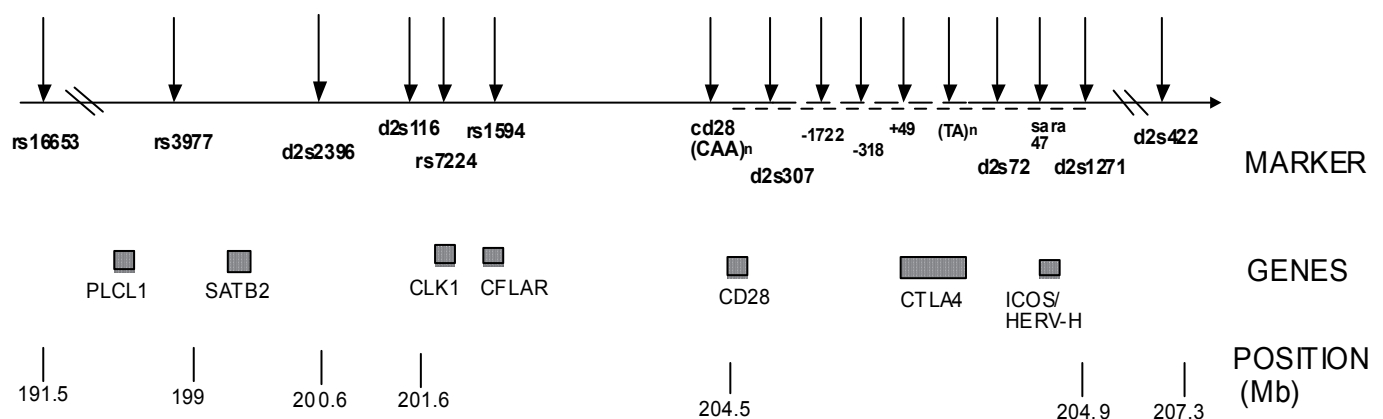

Figure 5. Genomic organization of the markers used in stage-1.

We went on to fine-map the obtained association signals. The association with rs3977 was originally found in a two independent datasets (consisting of 134 and 186 trio families) after HLA-DR15 stratification in the non-DR15 stratum ($p=0.02$ in both datasets). In order to further verify the above association signal, we analysed four additional markers flanking rs3977 (two microsatellites and two SNPs) and rs3977 as well within a 250 kb region in a new set of 309 Finnish MS trio families. No association with MS was found and we concluded that the initial finding with rs3977 was a false positive obtained by chance.

Initially we found an association with a 186bp allele of marker D2S1271 in two independent Southern Ostrobothnian set of families (stage-1 $p=0.01$ and stage-2 $p=0.008$). The candidate region defined by the marker D2S1271 is relatively large (approximately 300kb) based on linkage disequilibrium analyses, including two putative genes and two previously known genes (figure 6).

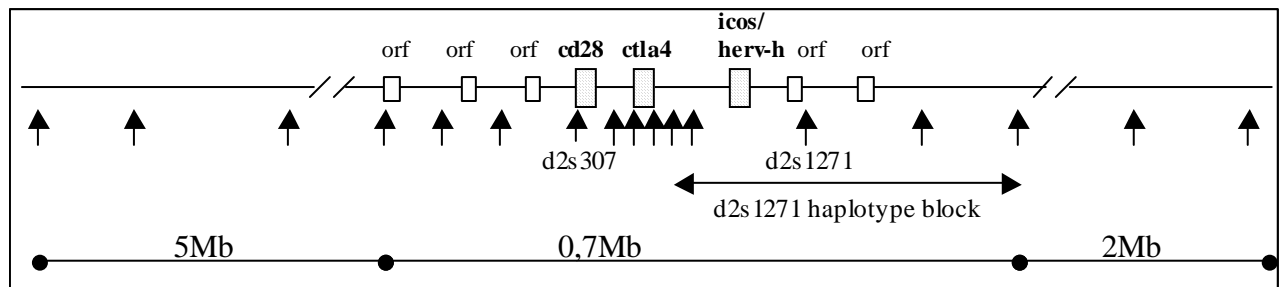

Figure 6. Genomic organization of the LD block centered around d2s1271. The vertical arrows indicate the genotyped markers.

In this genomic context the inducible T-cell co-stimulator (*ICOS*) gene is an obvious candidate for a role played in MS pathogenesis. It encodes a protein belonging to the family of Ig-like costimulatory receptors on the surface of T-cells. It delivers positive signals upon binding to its ligand, ICOS-L, and it is sequentially induced following T-cell activation. Previous studies have uncovered a heterogeneous role of ICOS in autoimmune disorders. ICOS-deficient mice are more vulnerable to EAE but are relatively resistant to experimental autoimmune myasthenia gravis and collagen-induced arthritis (Rottman et al, 2001; Scott et al, 2004; Nurieva, 2005). Furthermore in wild type mice, neutralizing antibodies against ICOS exacerbate EAE in the priming phase but inhibits it in the efferent phase (Rottman et al, 2001).

Sanroque mice carry a homozygous mutation in ROQ domain of Roquin, a ubiquitin ligase family member, that acts as a repressor of ICOS (Vinuesa et al, 2005). Such mutation disrupts the function of the protein, causing increased ICOS expression on T-cells and a systemic lupus erythematosus (SLE)-like syndrome. More recently Yu and colleagues (2007) have uncovered the underlying molecular pathway. ICOS expression is normally tightly regulated post-transcriptionally by a mechanism that involves a complementary conserved microRNA (miRNA) binding site for miR-101 located to the 3' untranslated region (UTR) of ICOS. Roquin usually inhibits ICOS expression by promoting the degradation of ICOS mRNA into the stress

granules, specialized cell structures involved in mRNA degradation (Newbury et al, 2007). It is not clear though whether Roquin mediates ICOS degradation by binding directly to its target mRNA or to the complementary miRNA.

Moreover the ICOS locus forms a gene complex with HERV-H, a member of the human endogenous retroviruses. HERV-H is located distally and in antisense orientation compared to ICOS (Figure 7).

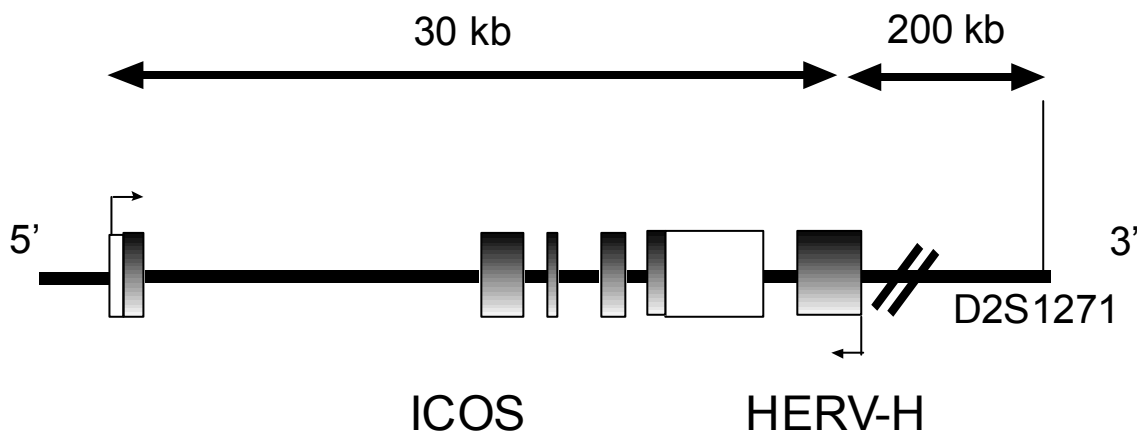

Figure 7. Schematic representation of the ICOS/HERV-H gene complex and its distance from the marker d2s1271.

HERV-H nucleic acid was detected in the serum in 40% of Danish MS patients vs. in 10% of controls (Christensen et al, 2003), indicating increased activation of HERV-H in MS patients. Additionally, increased antibody titers against HERV-H env protein were found in Danish MS patients (Christensen et al, 2003). Furthermore several cytokines utilizing the NF- κ B cascade (e.g. TNF α , IFN γ) activate HERV-H with a concomitant downregulation of ICOS (Ling V et al, 2001).

Against this background, variation in ICOS genomic region was analysed by sequencing and selected polymorphisms were tested for association with MS. We therefore aimed at extending our previous results by genotyping 27 SNPs spanning 100 kb across the *ICOS* gene region with respect to MS susceptibility (table 6).

<i>SNP</i>	<i>Position</i>	<i>Gene</i>	<i>MAF</i>	<i>p-value</i>
1. rs231770	204,437,398		0,46	0,17
2. rs16840252	204,439,764		0,13	0,35
3. rs5742909	204,440,592	150bp proximal of CTLA4	0,08	0,12
4. rs231775	204,440,959	CTLA4	0,46	0,47
5. rs3087243	204,447,164	300bp distal of CTLA4	0,32	0,74
6. rs960792	204,457,495		0,35	0,67
7. rs231755	204,461,814		0,14	0,3
8. rs2882974	204,468,309		0,37	0,76
9. rs10497873	204,470,572		0,15	0,71
10. rs11571311	204,481,924		0,21	0,82
11. rs3116505	204,487,426		0,48	0,79
12. rs11571306*	204,507,337		0,19	0,47
13. rs11889031*	204,507,639		0,06	0,7
14. rs4452124*	204,507,942		0,07	0,12
15. rs11571305*	204,508,371	1.5kb proximal of ICOS	0,18	0,55
16. rs10932029	204,510,013	ICOS / intron1	0,12	0,74
17. rs4355090	204,524,627	ICOS /intron1	0,20	0,23
18. rs4521021	204,524,820	ICOS / intron1	0,32	0,038
19. rs4270326*	204,529,859	ICOS / intron3	0,08	0,65
20. ICOSivs4+1070	204,531,932	ICOS / intron4	0,08	0,6
21. rs10172036	204,532,528	ICOS / intron4	0,39	0,95
22. rs10183087*	204,532,569	ICOS / 3' UTR	0,23	0,84
23. rs4404254*	204,533,531	ICOS / 3' UTR	0,22	0,75
24. rs10932037	204,533,591	ICOS / 3' UTR	0,11	0,69
25. rs1559931*	204,533,974	ICOS / 3' UTR	0,22	0,9
26. rs10199135*	204,536,856	2.3kb distal of ICOS	0,04	0,72
27. rs3116534*	204,542,014	HERV-H	0,23	0,67

Table 6. Results of the association analysis performed on chromosome 2q33. Asterisk (*) indicates SNPs genotyped only in 186 MS trio families.

One polymorphism, located in the first intron of the *ICOS* locus (rs4521021), showed a nominally significant trend for association. However when correction for multiple comparisons was applied the association was not significant. The LD analysis showed that the weakly

associated polymorphism lies in an interblock region, exhibiting low LD with neighbouring markers (figure 8). The presence of low LD in the genomic region where SNP rs4521021 lies was also confirmed in a recent study performed on celiac disease, IgA deficiency and common variable immunodeficiency patients by Haimila and colleagues (2009). Previously Lorentzen and colleagues (2005) have analyzed the role of variation in the ICOS gene in Norwegian MS patients. No association with the disease was found although the coverage of the region was poor (only two microsatellites were genotyped) with subsequent limited power. One of the two microsatellites included in the study was also genotyped in 186 Finnish MS trio families but it did not show association with the disease. Another study has investigated variations in 3' UTR of the *ICOS* gene in MS (Castelli et al, 2007). A correlation between a three SNPs haplotype and reduced ICOS expression was found. Homozygotes for such haplotype were underrepresented in MS patients when compared to controls and exhibited lower expression of ICOS and higher levels of circulating interleukin 10. Our study included five SNPs located in the 3' UTR of ICOS (we included also one SNP of the associated three markers haplotype) but no association could be detected. A recent GWAS performed in American and British patients did not find an association with the ICOS locus although only four SNPs (none of which was included in our study) were included (IMSGC, 2007).

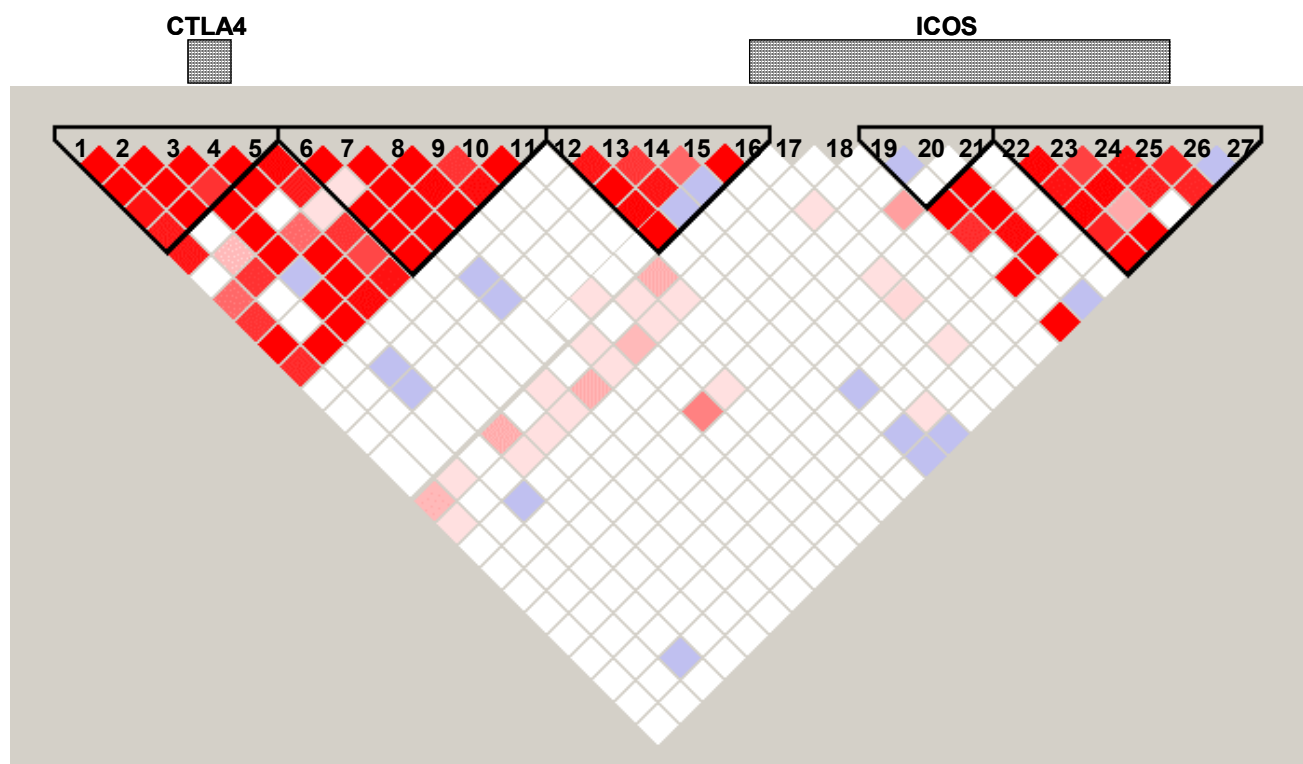

Figure 8. LD plot of chromosome 2q33. Darker color denotes higher LD (D'). Filled boxes indicates the genes. Numbers refer to the markers shown in Table 6.

Due to the close proximity of the weakly (non-significantly) associated SNP to the exon 2 boundary, we further characterized the expression of the *ICOS* gene, searching for possible alternative splicing. By reverse transcriptase-polymerase chain reaction (RT-PCR) two different isoforms were detected in inactivated and activated human CD4⁺ T-cells. A full length form of ICOS (fl-ICOS) and a splice variant lacking 450 nucleotides were identified (Figure 1B in Study IV). Sequence analysis revealed an alternatively spliced variant (Δ ex2-ICOS) that lacked exon 2 encoding most of the extracellular domain of fl-ICOS (Figure 9).

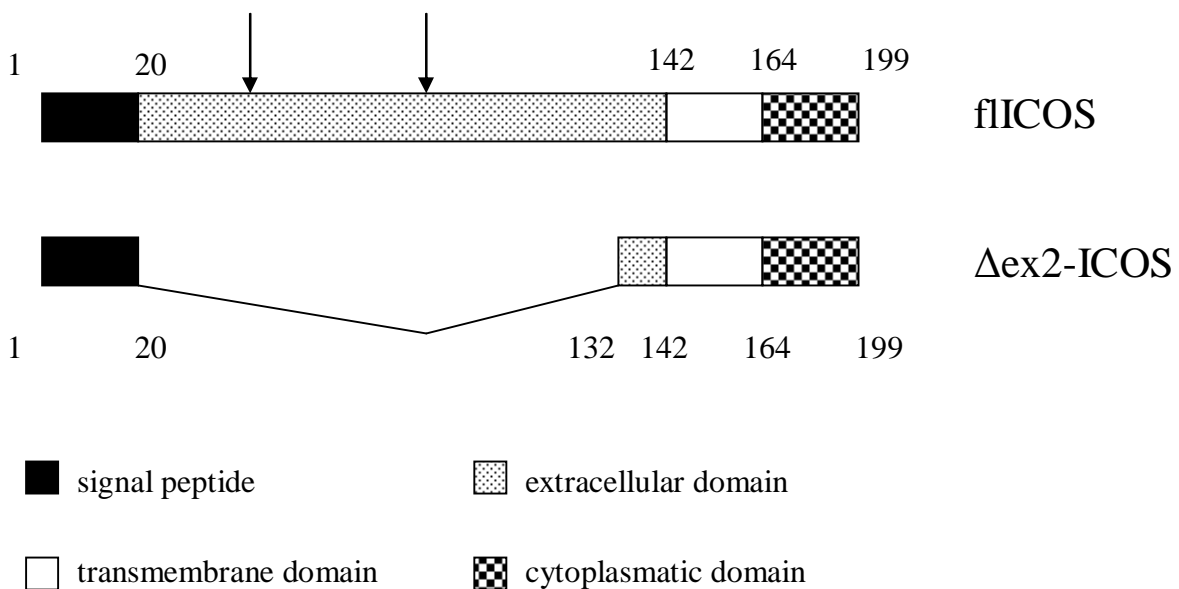

Figure 9. Schematic showing comparative protein domains of fl-ICOS and Δ ex2-ICOS. Numbers refer to amino acid positions in the nascent polypeptide. Arrows indicate the potential N-linked glycosylation sites.

The Δ ex2-ICOS is predicted to consist of just 86 residues, including signal sequence, ten amino acids of the extracellular domain, transmembrane domain and the cytoplasmic tail identical to fl-ICOS. Δ ex2-ICOS lacks thus most of the extracellular domain where the binding domain for its ligand, ICOS-L, lies. It has been showed that upon T-cell stimulation the expression of fl-ICOS is rapidly induced (Beier et al, 2000). We found that the expression kinetics of Δ ex2-ICOS was similar to fl-ICOS (Figure 1B in Study IV). We found that when CD4⁺ T-cells were stimulated with PMA and ionomycin, Δ ex2-ICOS mRNA levels increased accordingly.

To determine whether Δ ex2-ICOS transcript could direct protein production, the expression of Δ ex2-ICOS protein was studied in transfected cells and human-derived cell lines (Figure 2A and

2B in Study IV). Our results showed that Δ ex2-ICOS protein is expressed in non-activated Jurkat cells and that activation with PMA and ionomycin further increases the protein synthesis as expected from the RT-PCR experiment.

We made a further effort to study the subcellular localizations of fl-ICOS and Δ ex2-ICOS in transfected cells (Figure 3A and 3B in Study IV). As expected fl-ICOS was localized mostly at the cell membrane whereas Δ ex2-ICOS was found to be distributed mainly intracellularly with exclusion of the nuclei. Staining of the cells with an endoplasmic reticulum (ER) marker showed that fl-ICOS only partially colocalize with ER with most of the signal distributed at the cell membrane. Δ ex2-ICOS signal instead overlapped with the organelle marker labeled area, with most of the protein accumulated in the perinuclear region of ER.

We have reported a novel, possibly regulatory, transcriptional variant of ICOS. Alternative splicing of membrane receptors is a common strategy to increase the repertoire of receptors available to the cell. Other immune mediators such as CTLA4 and CD28 have shown a similar regulative mechanism. CTLA4 is known to have three splicing variants encoding for different proteins, a full length membrane bound (fl-CTLA4), a soluble (sCTLA4) and a ligand independent (liCTLA4) (Ueda et al., 2003; Vijaykrishnan et al., 2004). Also CD28 has been reported to undergo alternative splicing resulting in two different variants encoding for different proteins, a full-length (CD28) and a shorter variant (CD28i), both localized at the cell membrane (Hanawa et al, 2002). The mRNA of Δ ex2-ICOS lacks exon 2, which encodes for most of the extracellular domain of fl-ICOS, essential for interactions with its ligand, ICOS-L. Interestingly, both liCTLA4 and CD28i lack exon 2 as well and as a consequence they lack most of the ligand binding domain. However, both proteins are able to translocate to the cell surface in mammalian cells. Our results show instead that Δ ex2-ICOS protein is localized mainly intracellularly, with most of the signal present in ER. The differential subcellular localization of Δ ex2-ICOS when compared to fl-ICOS suggests that Δ ex2-ICOS might exert its function mostly in the ER. What could be its role in this subcellular compartment is still an open question. It is known that lectins (like calreticulin and calnexin) control retention of incorrectly glycosylated or folded proteins in the ER (Helenius, 1994). fl-ICOS bears two potential N-linked glycosylation sites, whereas Δ ex2-ICOS transcript lacks both sites. Loss of these glycosylation sites in Δ ex2-ICOS molecule might thus promote endoplasmic retention, preventing effective translocation of the receptor to the cell membrane. Future experiments are needed to uncover the function of Δ ex2-ICOS protein and its role in regulation of the overall ICOS expression.

2. IRF5 GENE AND MS

Nine SNPs and one pentanucleotide (CGGGG) insertion-deletion in the interferon regulatory factor 5 gene (IRF5) were selected for genotyping in three independent MS populations from Spain, Sweden and Finland. The markers included in the study were selected because of previous association with immune-mediated disorders or for their role in regulating IRF5 transcriptional levels. Two of the SNPs and the pentanucleotide insertion-deletion polymorphism revealed association with MS (Table 7). The two SNPs are located 5 kb upstream of the alternate promoter 1A and in the first intron respectively, whereas the pentanucleotide CGGGG is situated 64 bp upstream the alternate promoter 1A (Figure 9).

<i>POLYMORPHISM</i>	<i>SPANISH</i> <i>case (N=660) controls</i> <i>(N=833)</i> <i>p-value</i>	<i>SWEDISH</i> <i>cases (N=1166)</i> <i>controls (N=1235)</i> <i>p-value</i>	<i>FINNISH</i> <i>trios (n=511)</i> <i>p-value</i>	<i>COMBINED</i> <i>p-value</i>
rs4728142	0.003	0.02	0.035	0.0002
CGGGG indel	0.005	0.009	0.056	0.0005
rs3807306	0.004	0.049	0.012	0.0002

Table 7. SNPs associating with MS in the three different cohorts.

IRF5 consists of nine exons with three alternative non-coding 5' exons named 1A, 1B and 1C respectively (Figure 10). The majority of IRF5 transcripts starts with exon 1A which generates the most efficient 5'UTR in protein synthesis, whereas mRNA starting with exon 1C has inhibitory effect (Kozyrev et al 2007). The expression pattern of IRF5 is complex, involving nine at least splicing variants whose functional roles are still not well understood (Mancl et al 2005).

IRF5 belongs to the family of regulatory factors activated by type I interferon (IFN) pathway, a group of proteins involved in the regulation of immune responses (Taniguchi et al 2001). It is expressed mainly in dendritic and B-cells and its transcription is further enhanced by the activation of the IFN pathway (Mancl et al 2005). IRF5 is a cytoplasmatic protein anchored on endosomes by binding with MyD88 where it regulates toll-like receptors (TLR) signalling pathway. In the endosomal compartment TLRs 7/8 and 9 represent the internal sentinels of the

cell sensing infections (Honda and Taniguchi 2006). Upon activation of TLRs 7/8 and 9, IRF5 is phosphorylated and subsequently able to dimerize and translocate to the nucleus where it binds IFN-stimulated responsive elements (ISREs), DNA sequences that tune the expression of target genes.

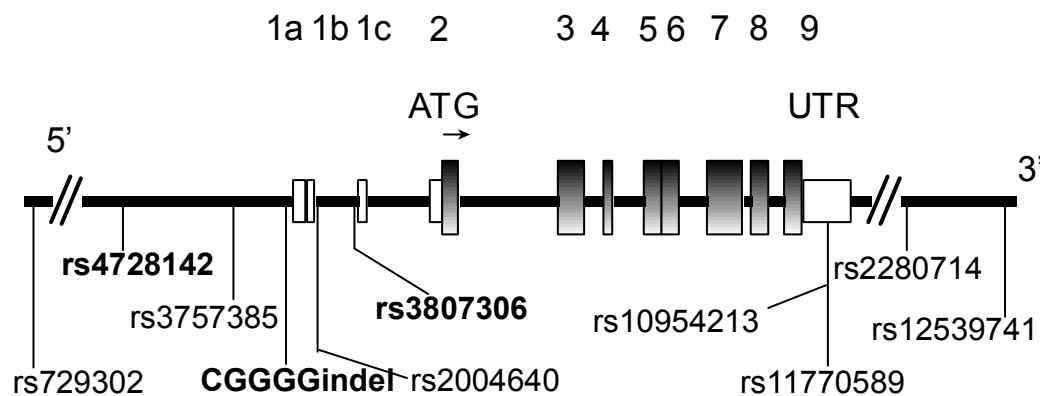

Figure 10. Genomic structure of IRF5 gene and polymorphisms included in the study. The markers associated with MS are shown in bold. UTR regions are indicated with empty boxes, coding exons are shown as shaded boxes.

IRF5 gene has already been associated with other autoimmune disorders such as SLE, rheumatoid arthritis (RA) and inflammatory bowel disorder (IBD) (Sigurdsson et al 2005, Sigurdsson et al 2007, Dideberg et al 2007). These studies suggest that a proximal and a distal region play a relevant role in the susceptibility to these diseases (Table 8).

<i>DISEASE</i>	<i>BEST ASSOCIATED POLYMORHISM</i>	<i>LOCATION</i>
IBD	CGGGG indel	promoter/first intron
Sjögren's syndrome	rs10488631	5 kb downstream of IRF5
Sjögren's syndrome	CGGGG indel	promoter/first intron
SLE	CGGGG indel	promoter/first intron
SLE	rs10954213	3' UTR
RA	rs3807306	promoter/first intron

Table 8. Summary of the IRF5 SNPs associated with autoimmune disorders.

This scenario is particularly relevant for SLE and Sjögren's syndrome, where the two gene regions are independently associated with the disease (Ferreiro-Neira et al 2007, Nordmark et al 2009) whereas in IBD, MS and RA the association is detected only from the proximal portion of IRF5. Our study is the first to address to the role of IRF5 in MS susceptibility. In the three independent cohorts from Sweden, Spain and Finland we found association with three markers located in the proximal part of the gene. These polymorphisms are in relatively high LD with each other and within the power of the analysis we cannot distinguish which one of them would be the primarily associated variant (Figure 2 in Study II). Furthermore the risk alleles were all present on the most common haplotype, whose association signal was comparable to the ones obtained in the single marker analysis. However, in a study on IBD patients the same three markers were associated with the disorder and, due to the effect size of the polymorphisms, it was possible to show that the pentanucleotide indel variation was the most significantly associated marker (Dideberg et al 2007).

Case-control association studies are affected by problems concerning population stratification, resulting in contradictory results among different studies. This lack of reproducibility is often attributed to marked variation of disease prevalence and marker allele frequency within subpopulations, yielding false evidence for an association (Cardon et al, 2003). Our study avoids these pitfalls by analysing the role of IRF5 gene in MS susceptibility in three different Caucasian populations. Furthermore the utilization of family-based in addition to case-control materials strengthens the results shown here.

In recent years data on genetic regulation of IRF5 has been accumulated (Figure 10). Graham and colleagues (2006) have described a functional SNP (rs2004640) that creates a donor splice site in the first intron, resulting in the inclusion of the alternative untranslated exon 1B. A second polymorphism (rs10954213) that alters the polyadenylation of the gene has been identified as modulator of the transcripts half-life (Graham et al 2007). Finally an insertion/deletion located in exon 6 encodes for a repetitive sequence in the PEST domain, a proline-rich region presumably involved in protein-protein interaction (Kozyrev et al 2007).

Our study has suggested a possible functional role for the polymorphisms associated with MS. We used electrophoretic mobility shift assay (EMSA) to test whether the alleles of the three variants associating with MS had differential protein binding. We detected stronger protein affinities for the risk alleles of the SNP rs4728142 and the indel variation, whereas both alleles

of the SNP rs3807306 seem to bind equal amounts of protein extract (Figure 3 in Study II). Sequence analysis of the insertion polymorphism revealed an additional binding site for SP1 and we further characterized the *in silico* prediction with the proximity ligation assay, a novel variant of immunoPCR (Gustafsdottir et al 2007). Indeed we were able to show that SP1 binds both alleles of the CGGGG repeat and increased amounts of SP1 bind to the risk allele (the 4xCGGGG allele). Interestingly the proximal region of IRF5 has a high content of CpG islands and several binding sites for SP1, two features that are very common in housekeeping genes because they ensure high expression. The increased binding affinity for SP1 in the case of the CGGGG insertion can drive higher expression of IRF5, with the carriers of the risk variant being more susceptible to higher levels of circulating type I IFN. It is worth noting that IRF5-deficient mice are vulnerable to viral infections and have a reduced level of type I IFN in their sera (Yanai et al 2007).

Ronnlom and co-workers (1991) reported an increased incidence of autoantibodies production and autoimmune disorders among cancer patients treated with alpha-interferon, suggesting almost twenty years ago that type I IFN could play a central role in autoimmune disorders pathogenesis. Recently increasing evidence has been accumulated in SLE, RA and Sjögren's syndrome (Baechler et al 2003, van der Pouw Kraan et al 2007, Bave et al 2005). In MS a subgroup of patients is characterized by increased expression of IFN-induced genes (van Baarsen et al 2006). Furthermore administration of IFN- β is one of the most common first-line strategies used to impact the early course of MS because of the IFN- γ antagonizing effects. However, IFN- β knockout (KO) mice are more susceptible to EAE compared to their wild-type littermates (Teige et al 2003). They develop also a more severe disease phenotype with more extensive CNS inflammation and demyelination. Although compensatory mechanisms induced by the lack of IFN- β cannot be ruled out, these findings suggest an important role played by type I IFN pathway in the pathogenesis of autoimmune disorders.

3. CHROMOSOME 19q13 AND MS

Sixteen markers located in the chromosomal region 19q13 were tested in 459 MS trio families for allelic association using the transmission disequilibrium test (TDT) (Figure 11); nominally significant associations were tested in an independent cohort of 323 families as well as in the pooled dataset of 782 families. No statistically significant association with MS was found.

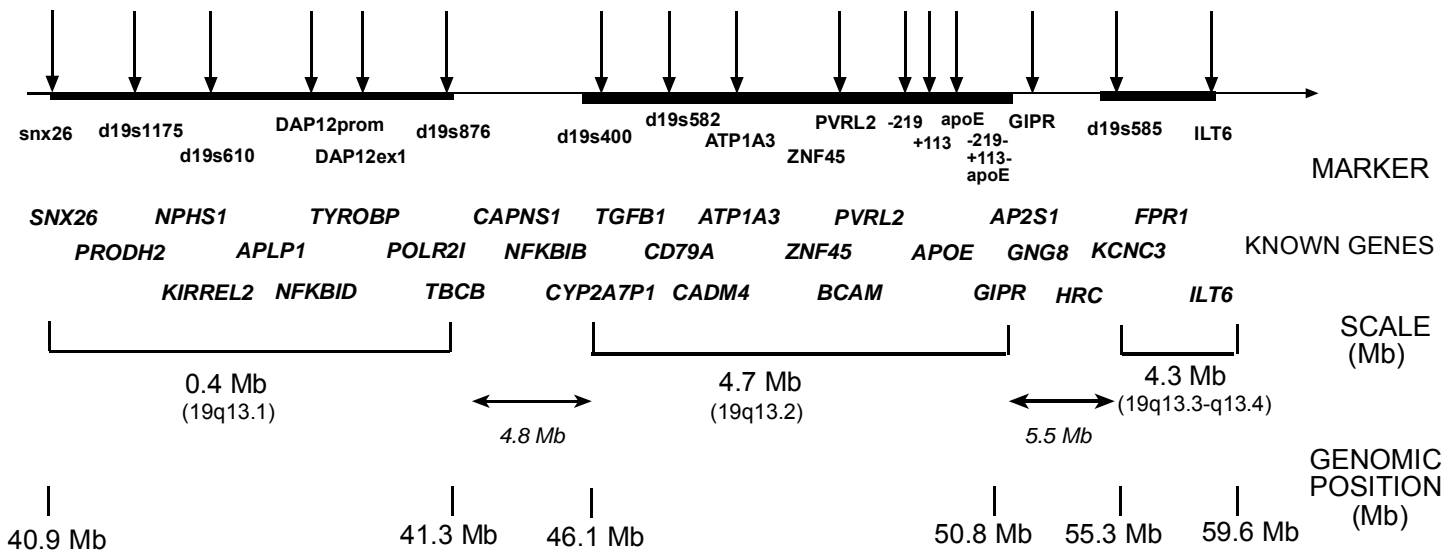

Figure 11. Genomic location of the marker included in chromosome 19q13 study.

Chromosome 19q13 is one of those genomic regions that have repeatedly provided linkage or association signals in MS although there is lack of replication in the published studies and no clear signal emerging from the region (Table 9). The results from linkage screens appear to be more consistent when compared to the association studies, although the statistical significance of most of the analyses is only modest (Table 9). Nevertheless, Wise et al (1999) have identified this chromosomal area as one of the most interesting non-HLA loci in a meta-analysis of linkage screens.

Table 9. Previous studied on the role of chromosome 19q13 in MS susceptibility.

Reference	Type of study	Best marker/subregion	Country	Subjects	Significance
Sawcer et al., 1996	Linkage	d19s246/19q13.4	UK	227 multiplex families	LOD=1
Haines et al., 1996	Linkage	d19s219/19q13.2	USA	52 multiplex families	LOD=1.13
Ebers et al., 1996	Linkage	d19s47/19q13.2	Canada	100 sibling pairs	LOD=0.73
Kuokkanen et al., 1997	Linkage	d19s246/19q13.4	Finland	16 multiples families	LOD=1
D'Alfonso et al., 1999	Linkage	19q13.3	Italy	69 families	LOD<0.7
Coraddu et al., 2001	Linkage	19q13	Italy/Sardinia	49 multiplex families	LOD<0.7
Broadley et al., 2001	Linkage	19q13	Italy	40 multiplex families	LOD<0.7
Green et al., 2001	Linkage	CEA/19q13.2	USA	161 multiplex	LOD=1.25
Xu et al., 2001	Linkage	D19S246/19q13.4	Sweden	46 multiplex families	NPL score -0.46
Reunanen et al., 2002	Linkage	d19s1175/19q13.1	Finland	27 multiplex families	LOD=1.8 (DR15-)
Haines et al., 2002	Linkage	d19s879/19q13.4	USA	98 multiplex families	LOD=3.01
Lucotte et al., 2002	Linkage	19q13.3	France	18 multiplex families	LOD=2.1
Pericak-Vance et al. 2004	Linkage	D19S217/19q13.2	USA	98 multiplex families	LOD=2.17
Pericak-Vance et al. 2004	Linkage	D19S217/19q13.2	USA	53 families, HLA-DR15+	LOD=2.37
Pericak-Vance et al. 2004	Linkage	D19S217/19q13.2	France	90 families	LOD<0.7
Haghighi et al., 2006	Linkage with OCB ^a	D2S219/19q13.2	Sweden	2 extended families	LOD=1.8
Schmidt et al., 2002	Association	APOE ε2-haplotype	USA	328 families	p=0.005
Yeo et al., 2003	Association	d19s585/19q13.4	UK	961 patients	p=0.12
Ban et al., 2003	Association	d19s219/19q13.2	Australia	217 patients	p=0.009
Koch et al., 2005	Association	ILT6/ 19q13.4	Germany, France	751 patients	p=0.009
Burwick RM et al., 2006	Association	APOE/19q13.2	meta-analysis	3200 patients	p>0.05
Burton et al., 2007	Association	ZNF45 and GIPR/19q13.2	UK	1000 patients	p=0.00005 and p=0.0008
Hafler et al., 2007	Association ^b	MAG, CD22, TYROBP/19q13.1 ^c	UK, USA	931 trios/2431 controls	p>0.05
Hafler et al., 2007	Association ^b	APOE, ZNF45, GIPR/19q13.2 ^c	UK, USA	931 trios/2431 controls	p>0.05
Hafler et al., 2007	Association ^b	synaptogyrin4/13q13.3 ^d	UK, USA	931 trios/2431 controls	p=0.02/0.0003
Hafler et al., 2007	Association ^b	ZNF577/19q13.4 ^d	UK, USA	931 trios/2431 controls	p=0.04/0.001

^a OCB= oligoclonal bands in cerebrospinal fluid.

^b We search for association on chromosome 19q13 between positions 40Mb and 60Mb for the following criteria: TDT statistics have a p-value<0.05 or CMH statistics have a p-value<0.001 (<https://imgsc.org/php/results.php>).

^c The 19q13.1 region harbouring *MAG*, *CD22*, *TYROBP* (40-42 Mb) and the 19q13.2 region harbouring *APOE*, *ZNF45* AND *GIPR* (49-51 Mb) were analysed with 128 and 177 markers, respectively, all of which failed to show any association (in both TDT and CMH statistics).

^d These markers fulfilled the association criteria.

Koch and colleagues (2005) reported increased frequency of *ILT6* deficiency in German MS patients compared to healthy controls (7.1% vs. 3.8%). The gene maps to the leukocyte receptor complex on 19q13.4, a genomic region which encodes for several immunological receptor proteins. We tested the role of *ILT6* deficiency in Finnish MS patients with TDT and case-control settings. In the family-based approach we could not detect any transmission distortion for the null allele and the frequency of the null genotype was only slightly increased in MS cases (14% vs. 11.6%), revealing no statistically significant association between *ILT6* deficiency and MS susceptibility. Recently Ordoñez et al (2009) have analyzed whether *ILT6* deletion associated with Spanish MS patients in a case-control study. *ILT6* deficiency in at least one chromosome was more common for MS cases (p-value = 0.006) although the increase of null-allele homozygotes was only marginally significant and not replicated in another independent dataset, questioning the primary role of *ILT6* in MS predisposition.

Located in 19q13.2 subregion, *APOE* has been the object of several studies using both linkage and allelic association approaches with conflicting results (Table 9). Already identified as a genomic region harbouring a putative predisposing MS gene in several screens (Multiple Sclerosis Genetic Group 1996, Sawcer et al 1996, Ebers et al 1996, Kuokkanen et al 1997), this area of chromosome 19 has been the focus of extensive research. A study combining linkage and association analysis in 98 families (Pericak-Vance et al 2001) suggested that a locus near *APOE* could affect the risk of developing MS; furthermore a HLA stratification analysis indicated that most of the positive LOD scores arose from DR-2 positive families. In an attempt to investigate a number of potentially interesting genomic regions with a linkage study, Pericak-Vance et al (2004) also tested subregion 19q13.2 in 98 American and 90 French multiplex families. Although no significant association with MS was found, stratification analysis revealed a maximum LOD of 1.07 in DR-15 negative families with a marker located in the vicinity of *APOE* locus. In a case-control study a marginal association of allele $\epsilon 4$ of *APOE* with protection to MS was found in a cohort of Chinese MS patients (Barcellos et al 1997). The functional *APOE* polymorphisms (alleles $\epsilon 2$, $\epsilon 3$ and $\epsilon 4$) and other SNPs in close vicinity were tested in a family-based association analysis (Schmidt et 2002). Single-marker analysis did not show any significant association whereas a four-marker haplotype including allele $\epsilon 2$ was associated with MS. When disease progression was included, the analysis showed that MS patients carrying allele $\epsilon 4$ are more likely to develop a severe clinical course. In a meta-analysis of 3200 MS cases and 2500 controls and 1200 family-based material, Burwick and colleagues (2006) were not able to detect any significant association of *APOE* epsilon allelic and genotypic

variation with MS susceptibility. Furthermore in a pooled analysis of over 4000 MS patients no evidence for an APOE epsilon influence on disease severity was found.

In our study we have genotyped three markers located near or within the gene locus and performed a single marker as well three-points haplotype analyses. We found a negative association with the -219T/+113C/ε3 haplotype which was underrepresented in MS patients with $p=0.007$. Curiously, this APOE haplotype has been showed to protect against Alzheimer disease in Finnish population (Myllykangas et al 2002). When tested in another independent dataset the initial association was not replicated as well as when association was analyzed in the two pooled datasets. Using the total cohort of MS patients in our possession, APOE haplotype analysis was performed also in a case-control setting but, again, no association was detected. Using the dataset-1 with 459 MS trio families we have approximately 80% power to detect a dominant predisposing variant with an odds ratio of 1.5 (marker and disease allele frequencies set to 0.20, D' value 1.0). With lower disease allele frequencies the power decreases. We concluded that, given the power of our study, allelic variation in *APOE* is unlikely to have a major role in genetic susceptibility to MS.

The other marker that showed initially negative association with MS in our study was D19S876, a microsatellite located in 19q13.1 subregion; when tested in a second independent dataset the allelic association with the microsatellite was not replicated. When the two datasets were pooled, p-value reached borderline nominal significance but it cannot be regarded as statistically significant since multiple comparisons were made. The same marker has been previously associated in continental Italian patients although the associated allele was different than in our study (D'Alfonso et al 2000). From these results we can conclude that the effect of the disease gene in LD with D19S876 might be modest and hence larger studies are needed to determine whether allelic variation in this genomic area significantly associates with MS.

In a previous study, Reunanen and co-workers (2002) obtained a LOD score of 1.8 in DR15-negative multiplex families peaking with D19S1175, a microsatellite located as well in the 19q13.1 subregion. In our dataset we could not find any statically significant association neither with D19S1175 nor with two candidate genes located in the close proximity, TYROBP and DAP10. TYROBP is of some interest since mutations in this locus are known to cause polycystic lipomembranous osteodysplasia with sclerosing leukoencephalopathy (PLOSL) disease, a multisystemic degenerative disorder characterized by demyelination of white matter. We also sequenced both genes in the proband of the multiplex family that mostly contributed to the LOD score but we could not detect any insertion/deletion or non-synonymous amino acid changes. Three

SNPs were found in the proximal end of TYROBP gene and two were included in the study but none of them revealed association with MS. These results have been strengthened in a recent study by Sulonen et al (2009) which revealed no association between TYROBP mutations implicated in PLOSL and MS in a linkage and association study.

The failure of identifying MS-associated variants highlights the limits of an indirect approach such as the allelic association study when common variants are not involved in the susceptibility of complex disorders. In the case of a more complex scenario where genetic and locus heterogeneity play a role then linkage studies still remain the best option. With the recent progress of technologies more direct tools like large-scale sequencing are becoming readily available and could complement linkage and association studies.

The previous linkage study in the DR15-negative multiplex families revealed a relatively sharp peak with D19S1175 marker (Reunanen et al 2002). Linkage analysis suggest recombination between the putative predisposing gene and markers D19S425 and D19S610, defining a candidate region of just 850 kb. This genomic area includes 48 genes of which some are of relevant interest in the context of MS. Two of the most obvious candidate genes that might be involved in disease susceptibility, myelin associated glycoprotein (MAG) and α -crystallin-related B6 (HSPB6), have been sequenced in families that mostly contributed to the LOD score, but no obvious mutations in exons were found (unpublished). Nevertheless this genomic region harbours other interesting candidate genes and a re-sequencing-based approach in selected patients might reveal new insights for the role of the 19q13.1 subregion in MS predisposition.

CONCLUSIONS AND FUTURE PROSPECTS

The work presented in this thesis has led to the identification of *IRF5* as a new MS susceptibility gene and has uncovered the presence of an alternative variant of *ICOS*, a member of co-stimulatory receptors on the surface of T-cells. Moreover the role of chromosomal region 19q13 in MS predisposition has been further analysed.

IRF5 gene has been already shown to be associated with other inflammatory or autoimmune disorders such as SLE, RA and IBD. We found evidence for a role of a common *IRF5* allele in MS susceptibility in analyses of three different populations. Three polymorphisms reached nominal significance for association with the disease and one of the risk alleles was functionally characterized, showing increased binding affinity for the transcriptional factor SP1. The findings presented here add to the evidence that there might be genes or pathways that are common between multiple immune-mediated diseases, and that type I IFN signalling, in which *IRF5* participates, is possibly one of these pathways. However, future studies are required to unequivocally identify the causative variants and to uncover the intricate expression profile of *IRF5* in MS patients.

The genomic scan for the role of chromosome 2q33 in MS predisposition excluded the candidacy of *CTLA4*, revealing a trend for association around *ICOS* gene. Although not statistically significant upon correction for multiple comparisons, the association signal suggests the need for a more thorough analysis of this locus and its involvement in MS pathogenesis. Focused analyses on geographical clusters with founder effect such as the Southern Ostrobothnian isolate, would minimize genetic and environmental heterogeneity and be informative in elucidating the role of this chromosomal region in MS susceptibility.

The work presented here opens new views on a more general immunological process such as the co-stimulatory pathway of immune responses and also expanded the knowledge about the expression of the *ICOS* gene. We discovered and further characterized a novel transcript isoform named Δ ex2-*ICOS*. The stability of the translated protein and its subcellular localization were investigated. This finding underlines the importance of alternative splicing as a regulator of immunological processes. The differential subcellular localization of Δ ex2-*ICOS* when compared to the full-length protein raises questions about the function of such protein in the co-stimulatory pathway. Future studies are needed to unravel the importance of this isoform in *ICOS* regulation. A better understanding of the

functional role of $\Delta x2$ -ICOS with respect to the subcellular environment and different T-cell subpopulations might shed more light on the mechanism underlying ICOS regulation.

Here we present also a follow-up analysis on chromosome 19q13 and MS. Although suggestive evidence for linkage had been reported in several studies, we were not able to detect any allelic association with MS. However a trend for association in subregion 19q13.1 might warrant further future investigation to dissect the role of allelic variation in our patients material. This analysis suggests that approaches based on linkage disequilibrium (allelic association) between marker alleles and MS susceptibility alleles may not be the method of choice to unravel predisposing genes risk alleles on this genomic region in case of genetic heterogeneity or variants with small risk. The putative susceptibility locus on this genomic area remains still elusive, suggesting a scenario that is more complex than previously assumed. Recently we have observed a shift in the field of complex genetics which is moving from LD-mapping of disease loci at population level to sequencing genomic DNA at individual level. The findings from GWASs to date have explained only a small fraction of the heritability for common diseases. This suggests that there are other genetic factors contributing to complex disorders but not yet discovered that are simply not detectable by this indirect approach. Nevertheless the use of high-throughput sequencing might also help to pinpoint disease genes in the associated loci found by case-control or family-based studies. Allelic and even locus heterogeneity within 19q13 might render the search for the causative variants quite demanding: a more direct, sequencing-based approach may be needed to solve the role of this genomic region in MS. The linkage analysis has suggested a possible role for a chromosomal area of approximately 850 kb that includes 48 genes. Some of the best candidate loci have been already sequenced in selected individuals with no obvious mutations detected in the coding region. Further sequence analysis might uncover allelic variation involved in MS genetic susceptibility.

Despite intense research we still do not have a clear knowledge about the pathogenic mechanisms underlying MS. Rather than a homogeneous and unitary disorder, MS is a phenotypically heterogeneous disease, representing most likely an overlapping spectrum of related conditions, such as opticospinal MS, PPMS and RRMS. This heterogeneity probably reflects different molecular backgrounds only partially shared among different forms of MS that in turn masks possible association signals. A more documented classification of the MS patients in future might help to develop more targeted approaches for deciphering the genetic bases of this disease.

The complex nature of the disease with several genes involved, each adding a small risk to the predisposition, has proven to be difficult to unravel. Nevertheless the results presented in this thesis work help to improve the understanding of the molecular background of this disorder. A better knowledge of disease pathogenesis could translate into targeted preventive strategies and possible future therapies.

REFERENCES

- Acheson ED, Bachrach CA, Wright FM. Some comments on the relationship of the distribution of multiple sclerosis to latitude, solar radiation and other variables. *Acta Neurol Scand* 1960; 35: 132-47.
- Altshuler D, Hirschhorn JN, Klannemark M et al. The common PPARgamma Pro12Ala polymorphism is associated with decreased risk of type 2 diabetes. *Nat Genet* 2000 26: 76-80.
- Alvarez-Lafuente R, Martinez A, Garcia-Montojo M et al. MHC2TA rs4774C and HHV-6A active replication in multiple sclerosis patients. *Eur J Neurol* 2009 Jul 29. [Epub ahead of print]
- Ascherio A, Munger KL. Environmental risk factors for multiple sclerosis. Part I: the role of infection. *Ann Neurol* 2007; 61: 288-99.
- Astier AL, Meiffren G, Freeman S, Hafler DA. Alterations in CD46-mediated Tr1 regulatory T cells in patients with multiple sclerosis. *J Clin Invest* 2006; 116: 3252-7.
- Aulchenko YS, Hoppenbrouwers IA, Ramagopalan SV et al. Genetic variation in the KIF1B locus influences susceptibility to multiple sclerosis. *Nat Genet* 2008; 40: 1402-3.
- Australia and New Zealand Multiple Sclerosis Genetics Consortium (ANZgene). Genome-wide association study identifies new multiple sclerosis susceptibility loci on chromosomes 12 and 20. *Nat Genet* 2009; 41: 824-8.
- Ausubel LJ, Kwan CK, Sette A et al. Complementary mutations in an antigenic peptide allow for crossreactivity of autoreactive T-cell clones. *Proc Natl Acad Sci USA* 1996; 93: 15317-23.
- Baechler EC, Batliwalla FM, Karypis G et al. Interferon-inducible gene expression signature in peripheral blood cells of patients with severe lupus. *Proc Natl Acad Sci USA* 2003; 100: 2610-5.
- Ban M, Goris A, Lorentzen AR et al. Replication analysis identifies TYK2 as a multiple sclerosis susceptibility factor. *Eur J Hum Genet* 2009; Mar 18 (Epub ahead of print).
- Baranzini SE, Wang J, Gibson RA et al. Genome-wide association analysis of susceptibility and clinical phenotype in multiple sclerosis. *Hum Mol Genet* 2009; 18: 767-78.
- Barcellos LF, Thomson G, Carrington M et al. Chromosome 19 single-locus and multilocus haplotype associations with multiple sclerosis. Evidence of a new susceptibility locus in Caucasian and Chinese patients. *JAMA* 1997; 278: 1256-61.
- Barcellos LF, Sawcer S, Ramsay PP et al. Heterogeneity at the HLA-DRB1 locus and risk for multiple sclerosis. *Hum Mol Genet* 2006; 15: 2813-24.
- Barkhof F, Filippi M, Miller DH et al. Comparison of MRI criteria at first presentation to predict conversion to clinically definite multiple sclerosis. *Brain* 1997; 120: 2059-69.
- Barton A, Woolmore JA, Ward D et al. Association of protein kinase C alpha (PRKCA) gene with multiple sclerosis in a UK population. *Brain* 2004; 127: 1717-22.
- Bave U, Nordmark G, Lovgren T et al. Activation of type I interferon system in primary Sjogren's syndrome: a possible etiopathogenetic mechanism. *Arthritis Rheum* 2005; 52: 1185-95.
- Bodmer WF. Evolutionary significance of the HL-A system. *Nature* 1972; 237: 139-45.
- Bodmer W, Bonilla C. Common and rare variants in multifactorial susceptibility to common diseases. *Nat Genet* 2008; 40: 695-701.
- Boldogh IR, Pon LA. Mitochondria on the move. *Trends Cell Biol* 2007; 17: 502-10.

- Bray PF. Antibodies against Epstein-Barr nuclear antigen (EBNA) in multiple sclerosis CSF, and two pentapeptide sequence identities between EBNA and myelin basic protein. *Neurology* 1992; 42: 1798-1804.
- Breij EC, Brink BP, Veerhuis R et al. Homogeneity of active demyelinating lesions in established multiple sclerosis. *Ann Neurol* 2008; 63: 16-25.
- Bulman DE, Ebers GC. The geography of MS reflects genetic susceptibility. *J Trop Geogr Neurol* 1992; 2: 66-72.
- Burger D, Molnarfi N, Weber MS et al. Glatiramer acetate increases IL-1 receptor antagonist but decreases T cell-induced IL-1beta in human monocytes and multiple sclerosis. *Proc Natl Acad Sci USA* 2009; 106: 4355-9.
- Burwick RM, Ramsay PP, Haines JL et al. APOE epsilon variation in multiple sclerosis susceptibility and disease severity: some answers. *Neurology* 2006; 66: 1373-83.
- Cardon LR, Palmer LJ. Population stratification and spurious allelic association. *Lancet* 2003; 361: 598-604.
- Cavanaugh J; IBD International Genetic Consortium. International collaboration provides convincing linkage replication in complex disease through analysis of a large pooled data set: Crohn disease and chromosome 16. *Am J Hum Genet* 2001; 68:1165-71.
- Challoner P, Smith K, Parker J et al. Plaque associated expression of human herpesvirus 6 in MS. *Proc Natl Acad Sci USA* 1995; 92: 7440-4.
- Chabas D, Baranzini SE, Mitchell D et al. The influence of the pro-inflammatory cytokine, osteopontin, on autoimmune demyelinating disease. *Science* 2001; 294: 1731-5.
- Chaudhuri A, Behan PO. The relationship of MS to physical trauma and psychological stress: report of the Therapeutics and Technology Assessment Subcommittee of the American Academy of Neurology. *Neurology* 2000; 54: 1393.
- Christensen T, Sorensen PD, Hansen HJ et al. Antibodies against a human endogenous retrovirus and the preponderance of env splice variants in multiple sclerosis patients. *Mult Scler* 2003; 9: 6-15.
- Cohen JC, Kiss RS, Pertsemlidis A et al. Multiple rare alleles contribute to low plasma levels of HDL cholesterol. *Science* 2004; 305: 869-72.
- Compston D.A, Batchelor JR, McDonald WI. B-lymphocyte alloantigens associated with multiple sclerosis. *Lancet* 1976; 2: 1261-1265.
- Compston A. The genetic epidemiology of multiple sclerosis. *J Neurol Neurosurg Psychiatry* 1997; 62: 553-61.
- Compston A, Confavreux C, Lassmann H et al. McAlpine's multiple sclerosis. London: Churchill Livingstone 2006; 113-81.
- Confavreux C, Hutchinson M, Hours MM et al. Rate of Pregnancy-Related Relapse in Multiple Sclerosis. *New Engl J Med* 1998; 339: 285-291.
- Corder EH, Saunders AM, Strittmatter WJ et al. Gene dose of apolipoprotein E type 4 allele and the risk of Alzheimer disease in late onset families. *Science* 1993; 261: 921-31.
- Cortese I, Tafi R, Grimaldi LM et al. Identification of peptides specific for cerebrospinal fluid antibodies in multiple sclerosis by using phage libraries. *Proc Natl Acad Sci USA* 1996; 93: 11063-7.
- D'Alfonso S, Nisitco L, Bocchio D et al. An attempt of identifying MS-associated loci as a follow-up of a genomic linkage study in the Italian population. *J Neurovirol* 2000; 6: S18-22.
- De Jager PL, Baecher-Allan C, Maier LM et al. The role of CD58 in multiple sclerosis. *Proc Natl Acad Sci USA* 2009; 106: 5264-9.
- De Jager PL, Jia X, Wang J et al. Meta-analysis of genome scans and replication identify CD6, IRF8 and TNFRSF1A as new multiple sclerosis susceptibility loci. *Nat Genet* 2009; 41: 776-82.

- Dideberg V, Krisjansdottir G, Milani L et al. An insertion deletion polymorphism in the Interferon Regulatory Factor 5 (IRF5) gene confers risk of inflammatory bowel diseases. *Hum Mol Genet* 2007; 16: 3008-16.
- Dyment DA, Sadovnick AD, Willer CJ et al. An extended genome scan in 442 Canadian multiple sclerosis-affected sibships: a report from the Canadian Collaborative Study Group. *Hum Mol Genet* 2004; 13: 1005-15.
- Dyment DA, Herrera BM, Cader MZ et al. Complex interactions among MHC haplotypes in multiple sclerosis: susceptibility and resistance. *Hum Mol Genet* 2005; 14: 2019-26.
- Ebers GC, Bulman DE, Sadovnick AD et al. A population-based study of multiple sclerosis in twins. *N Engl J Med* 1986; 315: 1638-42.
- Ebers GC, Kukay K, Bulman DE et al. A full genome search in multiple sclerosis. *Nat Genet* 1996; 13: 472-6.
- Elián M, Nightingale S, Dean G. Multiple sclerosis among United Kingdom-born children of immigrants from the Indian subcontinent, Africa and West Indies. *J Neurol Neurosurg Psychiatry* 1990; 53: 821-23.
- Etzensperger R, McMahon RM, Jones EY et al. Dissection of the multiple sclerosis associated DR2 haplotype. *J Autoimmun* 2008; 31: 201-7.
- Fernald GH, Yeh RF, Hauser SL et al. Mapping gene activity in complex disorders: Integration of expression and genomic scans for multiple sclerosis. *J Neuroimmunol* 2005; 167: 157-69.
- Ferreiro-Neira I, Calaza M, Alonso-Perez E et al. Opposed independent effects and epistasis in the complex association of IRF5 to SLE. *Genes Immun* 2007; 8: 429-38.
- Fraga MF, Ballestar E, Paz MF et al. Epigenetic differences arise during the lifetime of monozygotic twins. *Proc Natl Acad Sci USA* 2005; 102: 10604-9.
- Freedman DM, Dosemeci M, Alavanja MC. Mortality from multiple sclerosis and exposure to residential and occupational solar radiation: a case-control study based on death certificates. *Occup Environ Med* 2000; 57: 418-21.
- French Research Group on Multiple Sclerosis. Multiple sclerosis in 54 twinships: concordance rate is independent of zygosity. *Ann Neurol* 1992; 32: 724-7.
- Friese MA, Jakobsen KB, Friis L et al. Opposing effects of HLA class I molecules in tuning autoreactive CD8+ T cells in multiple sclerosis. *Nat Med* 2008; 14: 1227-35.
- Fujinami RS, Oldstone MB. Amino acid homology between the encephalitogenic site of myelin basic protein and virus: mechanism for autoimmunity. *Science* 1985; 230: 1043-5.
- Gale CR, Martyn CN. Migrant studies in multiple sclerosis. *Prog Neurobiol* 1995; 47: 425-448.
- Goldberg P. Multiple sclerosis: vitamin D and calcium as environmental determinants of prevalence (A viewpoint). Part 1: Sunlight, dietary factors and epidemiology. *Int J Environ Studies* 1974; 6: 19-27.
- Goodin DS. The relationship of MS to physical trauma and psychological stress: report of the Therapeutics and Technology Assessment Subcommittee of the American Academy of Neurology. *Neurology* 2000; 54: 1394.
- Goverman J, Woods A, Larson L et al. Transgenic mice that express a myelin basic protein-specific T cell receptor develop spontaneous autoimmunity. *Cell* 1993; 72: 551-60.
- Graham DS, Manku H, Wagner S et al. Association of IRF5 in UK SLE families identifies a variant involved in polyadenylation. *Hum Mol Genet* 2007; 16: 579-91.
- Graham RR, Kozyrev SV, Baechler EC et al. A common haplotype of interferon regulatory factor 5 (IRF5) regulates splicing and expression and is associated with increased risk of systemic lupus erythematosus. *Nat Genet* 2006; 38: 550-5.

- Gregory SG, Schmidt S, Seth P et al. Interleukin 7 receptor alpha chain (IL7R) shows allelic and functional association with multiple sclerosis. *Nat Genet* 2007; 39: 1083-91.
- Guerini FR, Losciale L, Mediati M et al. A polymorphism in the repetitive (TGGA)_n sequence 50 to the human myelin basic protein gene in Italian multiple sclerosis patients. *J Neurovirol* 2000; 6 (Suppl 2): 28-32.
- Gustafsdottir SM, Schlingemann J, Rada-Iglesias A et al. In Vitro analysis of DNA-protein interactions by proximity ligation. *Proc Natl Acad Sci USA* 2007; 104: 3067-72.
- Hafler JP, Maier ML, Cooper JD et al. CD226 Gly307Ser association with multiple autoimmune diseases. *Genes Immun* 2009; 10: 5-10.
- Hahn M, Nicholson MJ, Pyrdol J, Wucherpfennig KW. Unconventional topology of self peptide-major histocompatibility complex binding by a human autoimmune T cell receptor. *Nat Immunol* 2005; 6: 490-6.
- Haimila K, Einarsdottir E, de Kauwe A et al. The shared CTLA4-ICOS risk locus in celiac disease, IgA deficiency and common variable immunodeficiency. *Genes Immun* 2009; 10: 151-61.
- Hansen T, Skytthe A, Stenager A et al. Concordance for multiple sclerosis in Danish twins: an update of a nationwide study. *Mult Scler* 2005; 5: 504-10.
- Hammond SR, McLeod JG, Millingen KS et al. The epidemiology of multiple sclerosis in 3 Australian cities: Perth, Newcastle and Hobart. *Brain* 1988; 111: 1-25.
- Hanawa H, Ma Y, Mikolajczak SA et al. A novel costimulatory signaling in human T lymphocytes by a splice variant of CD28. *Blood* 2002; 99: 2138-2145.
- Harkioliaki M, Holmes SL, Svendsen P et al. T cell-mediated autoimmune disease due to low-affinity crossreactivity to common microbial peptides. *Immunity* 2009; 30: 348-57.
- Helenius A. How N-linked oligosaccharides affect glycoprotein folding in the endoplasmic reticulum. *Mol Biol Cell* 1994; 5: 253-265.
- Hernan MA, Olek MJ, Ascherio A. Cigarette smoking and incidence of multiple sclerosis. *Am J Epidemiol* 2001; 154: 69-74.
- Hernan MA, Jick SS, Logroscino G et al. Cigarette smoking and the progression of multiple sclerosis. *Brain* 2005; 128: 1461-5.
- Honda K, Taniguchi T. IRFs: master regulators of signaling by Toll-like receptors and cytosolic pattern-recognition receptors. *Nat Rev Immunol* 2006; 6: 644-58.
- Hoppenbrouwers IA, Aulchenko YS, Ebers GC et al. EVI5 is a risk gene for multiple sclerosis. *Genes Immun* 2008; 9: 334-7.
- Horton R, Wilming L, Rand V et al. Gene map of the extended human MHC. *Nat Rev Genet* 2004; 5: 889-99.
- Houtchens MK. Pregnancy and multiple sclerosis. *Semin Neurol* 2007; 27: 434-41.
- Huan J, Culbertson N, Spencer L et al. Decreased FOXP3 levels in multiple sclerosis patients. *J Neurosci Res* 2005; 81: 45-52.
- Hugot JP, Laurent-Puig P, Gower-Rousseau C et al. Mapping of a susceptibility locus for Crohn's disease on chromosome 16. *Nature* 1996; 379: 821-3.
- Hur EM, Youssef S, Haws ME et al. Osteopontin-induced relapse and progression of autoimmune brain disease through enhanced survival of activated T cells. *Nat Immunol* 2007; 8: 74-83.
- Ibsen SN, Clausen J. A repetitive DNA sequence 5' to the human myelin basic protein gene may be linked to MS in Danes. *Acta Neurol Scand* 1996; 93: 236-240.

The IFNB Multiple Sclerosis Study Group and the University of British Columbia MS/MRI Analysis Group. Interferon beta-1b in the treatment of multiple sclerosis: final outcome of the randomized controlled trial. *Neurology* 1995; 45: 1277-85.

International Multiple Sclerosis Genetics Consortium (IMSGC). Risk Alleles for Multiple Sclerosis Identified by a Genomewide Study. *N Engl J Med* 2007; 357: 851-62.

IMSGC. Refining genetic association in multiple sclerosis. *Lancet Neurol* 2008; 7: 567-9.

IMSGC. The expanding genetic overlap between multiple sclerosis and type I diabetes. *Genes Immun.* 2009; 10: 11-4.

Islam KTS, Gauderman JW, Cozen W, Mack TM. Childhood sun-exposure modifies risk of multiple sclerosis among monozygotic twins. *Ann Neurol* 2006; 60: S38 (Abstract).

Islam T, Gauderman J, Cozen W et al. Differential twin concordance for multiple sclerosis by latitude of birthplace. *Ann Neurol* 2006; 60: 56-64.

Jersild C, Svejgaard A, Fog T. HL-A antigens and multiple sclerosis. *Lancet* 1972; 1: 1240-1

Jersild C, Fog T, Hansen GS et al. Histocompatibility determinants in multiple sclerosis, with special reference to clinical course. *Lancet* 1973; 2: 1221-5.

Kabat EA, Glusman M, Knaub V. Quantitative estimation of the albumin and gamma-globulin in normal and pathologic cerebrospinal fluid by immunochemical methods. *Am J Med* 1948; 4: 653-62.

Kallio SP, Jakkula E, Purcell S et al. Use of a genetic isolate to identify rare disease variants: C7 on 5p associated with MS. *Hum Mol Genet* 2009; 18: 1670-83.

Kaminsky ZA, Tang T, Wang SC et al. DNA methylation profiles in monozygotic and dizygotic twins. *Nat Genet* 2009; 240-5.

Kaufman M, Gaydos CA, Sriram S et al. Is Chlamydia pneumoniae found in spinal fluid samples from multiple sclerosis patients? Conflicting results. *Mult Scler* 2002; 8: 289-94.

Kenealy SJ, Babron MC, Bradford Y et al. A second-generation genomic screen for multiple sclerosis. *Am J Hum Genet* 2004; 75: 1070-8.

Kim S, Liva SM, Dalal MA et al. Estriol ameliorates autoimmune demyelinating disease: implications for multiple sclerosis. *Neurology* 1999; 52: 1230-8.

Kinnunen E, Koskenvuo M, Kaprio J, Aho K. Multiple sclerosis in a nation-wide series of twins. *Neurology* 1987; 37: 1627-29.

Kittles RA, Perola M, Peltonen L et al. Dual origins of Finns revealed by Y chromosome haplotype variation. *Am J Hum Genet* 1998; 62: 1171-9.

Komurian-Pradel F, Paranhos-Baccala G, Bedin F et al. Molecular cloning and characterization of MSRv-related sequences associated with retrovirus-like particles. *Virology* 1999; 260: 1-9.

Korn T, Reddy J, Gao W et al. Myelin-specific regulatory T cells accumulate in the CNS but fail to control autoimmune inflammation. *Nat Med* 2007; 13: 423-31.

Kozyrev SV, Lewen S, Linga Reddy PMV et al. Structural insertion/deletion variation in IRF5 is associated with a risk haplotype and defines the precise IRF5 isoforms expressed in SLE. *Arthritis Rheum* 2007; 56: 1234-41.

Krumbholz M, Theil D, Cepok S et al. Chemokines in multiple sclerosis: CXCL12 and CXCL13 up-regulation is differentially linked to CNS immune cell recruitment. *Brain* 2006; 129: 200-11.

- Kuokkanen S, Gschwend M, Rioux JD et al. Genomewide scan of multiple sclerosis Finnish multiplex families. *Am J Hum Genet* 1997; 61: 1379-87.
- Kurtzke JF. Epidemiology of multiple sclerosis. In: Hallpike JF, Adams CWM, Tourtellotte WW (eds) Multiple sclerosis, Baltimore 1983: Williams and Wilkins, pp 47-96.
- Kurtzke JF. MS epidemiology world wide. One view of current status. *Acta Neurol Scand* 1995; 161 (suppl): 23-33.
- Kuusisto H, Kaprio J, Kinnunen E et al. Concordance and heritability of multiple sclerosis in Finland: study on a nationwide series of twins. *Eur J Neurol* 2008; 15: 1106-10.
- Lehmann PV, Sercarz. Spreading of T cell autoimmunity to cryptic determinants of an autoantigen. *Nature* 1992; 358: 155-7.
- Lehrer GM. The relationship of MS to physical trauma and psychological stress: report of the Therapeutics and Technology Assessment Subcommittee of the American Academy of Neurology. *Neurology* 2000; 54: 1393-4.
- Lemire JM, Archer DC. 1,25-dihydroxyvitamin D3 prevents the in vivo induction of murine experimental autoimmune encephalomyelitis. *J Clin Invest* 1991; 87: 1103-7.
- Lesage S, Zouali H, Cezard JP et al. CARD15/NOD2 mutational analysis and genotype-phenotype correlation in 612 patients with inflammatory bowel disease, *Am J Hum Genet* 2002; 70: 845-57.
- Ling V, Wu PW, Finnerty HF et al. 2001. Assembly and annotation of human chromosome 2q33 sequence containing the CD28, CTLA4, and ICOS gene cluster: analysis by computational, comparative, and microarray approaches. *Genomics* 2001; 78: 155-68.
- Lisak RP, Zweiman B. In vitro cell-mediated immunity of cerebrospinal-fluid lymphocytes to myelin basic protein in primary demyelinating diseases. *N Engl J Med* 1977; 297: 850-3.
- Lucchinetti C, Bruck W, Parisi J et al. Heterogeneity of multiple sclerosis lesions: implications for the pathogenesis of demyelination. *Ann Neurol* 2000; 47: 707-17.
- Lundmark F, Duvefelt K, Iacobaeus E et al. Variation in interleukin 7 receptor alpha chain (IL7R) influences the risk of multiple sclerosis. *Nat Genet* 2007; 39: 1108-13.
- Mameli G, Astone V, Arru G, et al. Brains and peripheral blood mononuclear cells of multiple sclerosis (MS) patients hyperexpress MS-associated retrovirus/HERV-W endogenous retrovirus, but not Human herpesvirus 6. *J Gen Virol* 2007; 88: 264-74.
- Mancl ME, Hu G, Sangster-Guity N et al. Two discrete promoters regulate the alternatively spliced human interferon regulatory factor-5 isoforms. Multiple isoforms with distinct cell type-specific expression, localization, regulation and function. *J Biol Chem* 2005; 280: 21078-90.
- Marrosu MG, Murru R, Murru MR et al. Dissection of HLA association with multiple sclerosis in the founder isolated population of Sardinia. *Hum Mol Genet* 2001; 10: 2907-16.
- Mattson DH, Roos RP, Arnason BGW. Isoelectric focusing of IgG eluted from multiple sclerosis and subacute sclerosing panencephalitis brains. *Nature* 1990; 287: 335-7.
- McDonald WI, Compston A, Edan G, et al. Recommended diagnostic criteria for multiple sclerosis: guidelines from the International Panel on the diagnosis of multiple sclerosis. *Ann Neurol* 2001; 50: 121-7.
- Mi S, Hu B, Hahm K et al. LINGO-1 antagonist promotes spinal cord remyelination and axonal integrity in MOG-induced experimental autoimmune encephalomyelitis. *Nat Med* 2007; 13:1228-1233.
- Mikol DD, Barkhof F, Chang P et al. Comparison of subcutaneous interferon beta-1a with glatiramer acetate in patients with relapsing multiple sclerosis (the REBif vs Glatiramer Acetate in Relapsing MS Disease [REGARD] study): a multicentre, randomised, parallel, open-label trial. *Lancet Neurol* 2008; 7: 903-14.

- Miller DH, Kendall BE, Barter BE et al. Magnetic resonance imaging in central nervous system sarcoidosis. *Neurology* 1988; 38: 378-83.
- Miller DH, Leary SM. Primary-progressive multiple sclerosis. *Lancet Neurol* 2007; 6:903-12.
- Multiple Sclerosis Genetic Group. A complete genomic screen for multiple sclerosis underscores a role for the major histocompatibility complex. *Nat Genet* 1996; 13: 469-76.
- Morgan IM. Allergic encephalomyelitis in monkeys in response to injection of normal monkey nervous tissue. *J. Exp. Med.* 1947; 85: 131-140.
- Morton NE. Sequential tests for the detection of linkage. *Am J Hum Genet* 1955; 7: 277-318.
- Mumford C, Wood N, Kellar-Wood H et al. The British Isles survey of multiple sclerosis in twins. *Neurology* 1994; 44: 11-5.
- Munger KL, Zhang SM, O'Reilly E et al. Vitamin D intake and incidence of multiple sclerosis. *Neurology* 2004; 62: 60-65.
- Munger KL, Levin LI, Hollis BW et al. Serum 25-hydroxyvitamin D levels and risk of multiple sclerosis. *JAMA* 2006; 296: 2832-38.
- Myllykangas L, Polvikoski T, Reunanen K et al. ApoE epsilon3-haplotype modulates Alzheimer beta-amyloid deposition in the brain. *Am J Med Genet* 2002; 114: 288-91.
- Naito S, Namerow N, Mickey MR, Terasaki PI. Multiple sclerosis: association with HL-A3. *Tissue Antigens* 1972; 2: 1-4.
- Nangaku M, Sato-Yoshitake R, Okada Y et al. KIF1B, a novel microtubule plus end-directed monomeric motor protein for transport of mitochondria. *Cell* 1994; 79: 1209-20.
- Nave KA, Trapp BD. Axon-glia signaling and the glial support of axon function. *Annu Rev Neurosci* 2008; 31: 535-61.
- Neuhaus O, Kieseier BC, Hartung H-P. Immunosuppressive agents in multiple sclerosis. *Neurotherapeutics* 2007; 4: 654-60.
- Newbury SF, Muhlemann O, Stoecklin G. Turnover in the Alps: an mRNA perspective. Workshops on mechanisms and regulation of mRNA turnover. *EMBO Rep* 2006; 7: 143-8.
- Nordmark G, Kristjansdottir G, Theander E et al. Additive effects of the major risk alleles of IRF5 and STAT4 in primary Sjögren's syndrome. *Genes Immun* 2009; 10: 68-76.
- Nurieva RI. Regulation of immune and autoimmune responses by ICOS-B7h interaction. *Clin Immunol* 2005; 115: 19-25.
- Ogura Y, Bonen DK, Inohara N et al. A frameshift mutation in NOD2 associated with susceptibility to Crohn's disease. *Nature* 2001; 411: 603-6.
- Oksenberg JR, Barcellos LF, Cree BA et al. Mapping multiple sclerosis susceptibility to HLA-DR locus in African Americans. *Am J Hum Genet* 2004; 74: 160-7.
- Ordonez D, Sanchez AJ, Martinez-Rodriguez JE et al. Multiple sclerosis associates with LILRA3 deletion in Spanish patients. *Genes Immun* 2009; 10: 579-85.
- Ota K et al. T-cell recognition of an immunodominant myelin basic-protein epitope in multiple sclerosis. *Nature* 1990; 346: 183-7.
- Ott J. Analysis of human genetic linkage. Baltimore and London: the Johns Hopkins University Press, 1991.

- Ousman SS, Tomooka BH, Van Noort JM et al. Protective and therapeutic role for $\alpha\beta$ -crystallin in autoimmune demyelination. *Nature* 2007; 448: 474-9.
- Panitch HS, Hirsch RL, Schindler J et al. Treatment of multiple sclerosis with gamma interferon Exacerbations associated with activation of the immune system. *Neurology* 1987; 37:1097-102.
- Panitch HS. Influence of infection on exacerbations of multiple sclerosis. *Ann Neurol* 1994; 36 Suppl: S25-8.
- Patani R, Balaratnam M, Vora A, Reynolds R. Remyelination can be extensive in multiple sclerosis despite a long disease course. *Neuropathol Appl Neurobiol* 2007; 33: 277-87.
- Patrikios P, Stadelmann C, Kutzelnigg A et al. Remyelination is extensive in a subset of multiple sclerosis patients. *Brain* 2006; 129: 3165-72.
- Peltonen L, Palotie A, Lange K. Use of population isolates for mapping complex traits. *Nat Rev Genet* 2000; 1: 182-90.
- Pericak-Vance MA, Rimmler JB, Martin ER et al. Linkage and association analysis of chromosome 19q13 in multiple sclerosis. *Neurogenetics* 2001; 3: 195-201.
- Pericak-Vance MA, Rimmler JB, Haines JL et al. Investigation of seven proposed regions of linkage in multiple sclerosis: an American and French collaborative study. *Neurogenetics* 2004; 5: 45-8.
- Perron H, Garson JH, Bedin F et al. Molecular identification of a novel retrovirus repeatedly isolated from patients with multiple sclerosis. The Collaborative Research Group on Multiple Sclerosis. *Proc Natl Acad Sci USA* 1997; 94: 7583-8.
- Pihlaja H, Rantamaki-Hakkinen T, Wikstrom J et al. Linkage disequilibrium between myelin basic protein (MBP) microsatellite and multiple sclerosis is restricted to a geographically-defined subpopulation in Finland. *Genes Immun* 2003; 4: 138-46.
- Polman CH, O'Connor PW, Havrdova E et al. A randomized, placebo-controlled trial of natalizumab for relapsing multiple sclerosis. *N Engl J Med* 2006; 354: 899-910.
- Poser CM, Paty DW, Scheinberg L, et al. New diagnostic criteria for multiple sclerosis: guide-lines for research protocols. *Ann Neurol* 1983;13: 227-31.
- Poser CM. The dissemination of multiple sclerosis: a Viking saga? A historical assay. *Ann Neurol* 1994; 36: S231-43.
- Poser CM. Pathogenesis of multiple sclerosis: a commentary. *Clin Neurol Neurosurg* 2000; 102: 191-194
- Poser CM. The relationship of MS to physical trauma and psychological stress: report of the Therapeutics and Technology Assessment Subcommittee of the American Academy of Neurology. *Neurology* 2000; 54: 1393.
- Poskanzer DC, Prenney LB, Sheridan JL, Yon Kondy J. Multiple sclerosis in the Orkney and Shetland islands I: Epidemiology, clinical factors and methodology. *J Epidemiol Comm Health* 1980; 34: 229-39.
- Ramagopalan SV, Morris AP, Dymant DA et al. The inheritance of resistance alleles in multiple sclerosis. *PLoS Genet* 2007; 3: 1607-13.
- Ramagopalan SV, Anderson C, Sadovnick AD, Ebers GE. Genome wide study of multiple sclerosis. *N Engl J Med* 2007; 357: 2199-2200.
- Ramagopalan SV, Maugeri NJ, Handunnetthi L et al. Expression of the multiple sclerosis-associated MHC class II Allele HLA-DRB1*1501 is regulated by vitamin D. *PLoS Genet* 2009; 5: e1000369.
- Reich DE, Lander ES. On the allelic spectrum of human disease. *Trends Genet* 2001; 17: 502-10.
- Reijonen H, Novak EJ, Kochik S et al. Detection of GAD65-specific T-cells by major histocompatibility complex class II tetramers in type 1 diabetic patients and at-risk subjects. *Diabetes* 2002; 51: 1375-82.

- Reunanen K, Finnila S, Laaksonen M et al. Chromosome 19q13 and multiple sclerosis susceptibility in Finland: a linkage and two-stage association study. *J Neuroimmunol* 2002; 126: 134-42.
- Rioux JD, Xavier RJ, Taylor KD et al. Genome-wide association study identifies new susceptibility loci for Crohn disease and implicates autophagy in disease pathogenesis. *Nat Genet* 2007; 39: 596–604.
- Risch N and Merikangas K. The future of genetic studies of complex human diseases. *Science* 1996; 273: 1516-7.
- Ristori G, Cannoni S, Stazi A et al. Multiple sclerosis in twins from continental Italy and Sardinia: a nationwide study. *Ann Neurol* 2006; 59: 27-34.
- Rivers TM, Sprunt DH, Berry GP. Observations on attempts to produce acute disseminated encephalomyelitis in monkeys. *J Exp Med* 1933; 58: 39-53.
- Ronnblom LE, Alm GV, Oberg KE. Autoimmunity after alpha-interferon therapy for malignant carcinoid tumors. *Ann Intern Med* 1991; 115: 178-83.
- Rosati G, Aiello I, Pirastru M I et al. Sardinia, a high-risk area for multiple sclerosis: a prevalence and incidence study in the district of Alghero. *Ann Neurol* 1987; 21: 190-4.
- Rottman JB, Smith T, Tonra JR, et al. The costimulatory molecule ICOS plays an important role in the immunopathogenesis of EAE. *Nat Immunol* 2001; 2: 605-11.
- Rubio JP, Bahlo M, Butzkueven H et al. Genetic dissection of the human leukocyte antigen region by use of haplotypes of Tasmanians with multiple sclerosis. *Am J Hum Genet* 2002; 70: 1125-37.
- Rudick RA, Goodkin DE, Jacobs LD et al. Impact of interferon beta-1a on neurologic disability in relapsing multiple sclerosis. The Multiple Sclerosis Collaborative Research Group (MSCRG). *Neurology* 1997; 49: 358-63.
- Rudick RA. Disease-modifying drugs for relapsing-remitting multiple sclerosis and future directions for multiple sclerosis therapeutics. *Arch Neurol* 1999; 56: 1079-84.
- Saarela J, Kallio SP, Chen D et al. PRKCA and multiple sclerosis: association in two independent populations. *PLoS Genet* 2006; 2: e42.
- Sabatti C, Service SK, Hartikainen SL et al. Genome-wide association analysis of metabolic traits in a birth cohort from a founder population. *Nat Gen* 2009; 41: 35-46.
- Sadovnick A, Armstrong H, Rice P et al. A Population-based study of multiple sclerosis in twins: Update. *Ann Neurol* 1993; 33: 281-5.
- Sajantila A, Salem AH, Savolainen P et al. Paternal and maternal DNA lineages reveal a bottleneck in the founding of the Finnish population. *Proc Natl Acad Sci USA* 1996; 93: 12035-9.
- Sakaguchi S. Regulatory T cells: key controllers of immunologic self-tolerance. *Cell* 2000; 101: 455-8.
- Saxena R, Voight BF, Lyssenko V, Burt NP et al. Genome-wide association analysis identifies loci for type 2 diabetes and triglyceride levels. *Science* 2007; 316: 1331–6.
- Sawcer S, Jones HB, Feakes R et al. A genome screen in multiple sclerosis reveals susceptibility loci on chromosome 6p21 and 17q22. *Nat Genet* 1996; 13: 464-8.
- Sawcer S, Ban N, Maranian M et al. A high-density screen for linkage in multiple sclerosis. *Am J Hum Genet* 2005; 77: 454-67.
- Schmidt S, Barcellos LF, DeSombre K et al. 2002. Association of polymorphisms in the apolipoprotein E region with susceptibility to and progression of multiple sclerosis. *Am J Hum Genet* 2002; 70: 708–717.

- Schumacher GA, Beebe GW, Kibler RF et al. Problems of experimental trials of therapy in multiple sclerosis: Report by the panel on the evaluation of experimental trials of therapy in multiple sclerosis. *Ann NY Acad Sci* 1965; 122: 552-68.
- Scott BG, Yang H, Tuzun E et al. ICOS is essential for the development of experimental autoimmune myasthenia gravis. *J Neuroimmunol* 2004; 153: 16-25.
- Serafini B, Rosicarelli B, Magliozzi R et al. Detection of ectopic B-cell follicles with germinal centers in the meninges of patients with secondary progressive multiple sclerosis. *Brain Pathol* 2004; 14: 164-74.
- Serafini B, Rosicarelli B, Franciotta D et al. Dysregulated Epstein-Barr virus infection in the multiple sclerosis brain. *J Exp Med* 2007; 204: 2899-912.
- Shifman S, Darvasi A. The value of isolated populations. *Nat Genet* 2001; 28: 309-10.
- Sigurdsson S, Nordmark G, Goring HH et al. Polymorphisms in the tyrosine kinase 2 and interferon regulatory factor 5 genes are associated with systemic lupus erythematosus. *Am J Hum Genet* 2005; 76: 528-37.
- Sigurdsson S, Padyukov L, Kurreeman FA et al. Association of a haplotype in the promoter region of the interferon regulatory factor 5 gene with rheumatoid arthritis. *Arthritis Rheum* 2007; 56: 2202-10.
- Smith ADM, Duckett S, Waters AH. Neuropathological changes in chronic cyanide intoxication. *Nature* 1963; 200: 179-181.
- Smith KJ, Pyrdol J, Gauthier L et al. Crystal structure of HLA-DR2 (DRA*0101, DRB1*1501) complexed with a peptide from human myelin basic protein. *J Exp Med* 1998; 188: 1511-1520.
- Sola P, Merelli E, Marasca R et al. Human herpesvirus 6 and multiple sclerosis: survey of anti-HHV-6 antibodies by immunofluorescence analysis and of viral sequences by polymerase chain reaction. *J Neurol Neurosurg Psychiatry* 1993; 56: 917-9.
- Soldan SS, Berti R, Salem N et al. Association of human herpes virus 6 (HHV-6) with multiple sclerosis: increased IgM response to HHV-6 early antigen and detection of serum HHV-6 DNA. *Nat Med* 1997; 3: 1394-7.
- Sopori ML, Kozak W. Immunomodulatory effects of cigarette smoke. *J Neuroimmunol* 1998; 83: 148-156.
- Sriram S, Mitchell W, Stratton C. Multiple sclerosis associated with Chlamydia pneumoniae infection of the CNS. *Neurology* 1998; 50: 571-2.
- Sulonen AM, Kallio SP, Ellonen P et al. No evidence for shared etiology in two demyelinating disorders, MS and PLOSL. *J Neuroimmunol* 2009; 206: 86-90.
- Sumelahti ML, Tienari PJ, Wikström J et al. Increasing prevalence of multiple sclerosis in Finland. *Acta Neurol Scand* 2001; 103: 153-8.
- Taniguchi T, Ogasawara K, Takaoka A, Tanaka N. IRF family of transcription factors as regulators of host defense. *Annu Rev Immunol* 2001; 19: 623-55.
- Teige I, Treschow A, Teige A et al. IFN-beta gene deletion leads to augmented and chronic demyelinating experimental autoimmune encephalomyelitis. *J Immunol* 2003; 170: 4776-84.
- Terasaki PI, Parks MS, Opelz G, Ting A. Multiple sclerosis and high incidence of a B lymphocyte antigen. *Science* 1976; 193: 1245-7.
- Teutsch SM, Booth DR, Bennets BH et al. Identification of 11 novel and common single nucleotide polymorphisms in the interleukin-7 receptor alpha gene and their associations with multiple sclerosis. *Eur J Hum Genet* 2003; 11: 509-15.
- Thorpe J, Mumford C, Compston D et al. British Isles survey of multiple sclerosis in twins: MRI. *J Neurol, Neurosurg and Psychiatry* 1994; 57: 491-6.

- Tienari PJ, Wikstrom J, Sajantila A et al. Genetic susceptibility to multiple sclerosis linked to myelin basic protein gene. *Lancet* 1992; 340: 987-91.
- Tienari PJ, Sumelahti ML, Rantamäki T, Wikström J. Multiple sclerosis in western Finland: evidence for a founder effect. *Clin Neurol Neurosurg* 2004; 106: 175-9.
- Tienari PJ, Kuokkanen S, Pastinen T et al. Golli-MBP gene in multiple sclerosis susceptibility. *J Neuroimmunol* 1998; 81: 158-67.
- Toivanen P, Vaahtovuori J, Eerola E. Influence of major histocompatibility complex on bacterial composition of fecal flora. *Infect Immun* 2001; 69: 2372-7.
- Ueda H, Howson JM, Esposito L et al. Association of the T-cell regulatory gene CTLA4 with susceptibility to autoimmune disease. *Nature* 2003; 423: 506-11.
- van Baarsen LG, van der Pouw Kraan TC, Kragt JJ et al. A subtype of multiple sclerosis defined by an activated immune defense program. *Genes Immun* 2006; 7: 522-31.
- Van Bockxmeer FM, Mamotte CD. Apolipoprotein epsilon 4 homozygosity in young men with coronary heart disease. *Lancet* 1992; 340: 879-80.
- van der Mei IA, Ponsonby AL, Dwyer T et al. Past exposure to sun, skin phenotype, and risk of multiple sclerosis: case-control study. *BMJ* 2003; 327: 316.
- van der Pouw Kraan TC, Wijbrandts CA, van Baarsen LG et al. Rheumatoid arthritis subtypes identified by genomic profiling of peripheral blood cells: assignment to type I interferon signature in a subpopulation of patients. *Ann Rheum Dis* 2007; 66: 1008-14.
- Vijaykrishnan L, Slavik JM, Illes Z et al. An autoimmune disease-associated CTLA-4 splice variant lacking the B7 binding domain signals negatively in T cells. *Immunity* 2004; 20: 563-75.
- Vinuesa CG, Cook MC, Angelucci C et al. A RING-type ubiquitin ligase family member required to repress follicular helper T cells and autoimmunity. *Nature* 2005; 435: 452-8.
- Wang J, Ioan-Facsinay A, van der Voort EI et al. Transient expression of FOXP3 in human activated nonregulatory CD4+ Treg cells. *Eur J Immunol* 2007; 37: 129-38.
- Warner HB, Carp RI. Multiple sclerosis and Epstein-Barr virus. *Lancet* 1981; 2: 1290.
- Wellcome Trust Case Control Consortium (WTCCC). Genome-wide association study of 14,000 cases of seven common diseases and 3,000 shared controls. *Nature* 2007; 447: 661-78.
- Westall FC. Molecular mimicry revisited: gut bacteria and multiple sclerosis. *J Clin Microbiol* 2006; 44: 2099-104.
- Westlund K. Distribution and mortality time trend of multiple sclerosis and some other disease in Norway. *Acta Neurol Scand* 1970; 46: 455-83.
- Wikström J. Studies on the clustering of multiple sclerosis in Finland II: microepidemiology in one high-risk county with special reference to familial cases. *Acta Neurol Scand* 1975; 51: 173-83.
- Willer CJ, Dyment DA, Risch N et al. Twin Concordance and sibling recurrence rates in multiple sclerosis. *Proc Natl Acad Sci USA* 2003; 100: 1277-82.
- Willer CJ, Dyment DA, Sadovnick AD et al, for the Canadian Collaborative Study Group. Timing of birth and risk of multiple sclerosis: population based study. *BMJ* 2005; 330:120.
- Willer CJ, Herrera B, Morrison KM et al. Association between microchimerism and multiple sclerosis in Canadian twins. *J Neuroimmunol* 2006; 179: 145-51.

- Wolinsky JS, Narayana PA, O'Connor P et al. Glatiramer acetate in primary progressive multiple sclerosis: results of a multinational, multicenter, double-blind, placebo-controlled trial. *Ann Neurol* 2007; 61: 14-24.
- Wucherpfennig KW, Strominger JL. Molecular mimicry in T cell-mediated autoimmunity: viral peptides activate human T cell clones specific for myelin basic protein. *Cell* 1995; 80: 695-705.
- Yanai H, Chen HM, Inuzuka T et al. Role of IFN regulatory factor 5 transcription factor in antiviral immunity and tumor suppression. *Proc Natl Acad Sci USA* 2007; 104: 3402-7.
- Yeo TW, De Jager PL, Gregory SG et al. A second major histocompatibility complex susceptibility locus for multiple sclerosis. *Ann Neurol* 2007; 61: 228-36.
- Yu D, Tan AH, Hu X et al. Roquin represses autoimmunity by limiting inducible T-cell co-stimulator messenger RNA. *Nature* 2007; 450: 299-303.
- Yudkin PL, Ellison GW, Ghezzi A, et al: Overview of azathioprine treatment in multiple sclerosis. *Lancet* 1991; 338: 1051-5.
- Zhang Z, Duvefelt K, Svensson F et al. Two genes encoding immune-regulatory molecules (LAG3 and IL7R) confer susceptibility to multiple sclerosis. *Genes Immun* 2005; 6: 145-52.
- Zoledziewska M, Costa G, Pitzalis M et al. Variation within the CLEC16A gene shows consistent disease association with both multiple sclerosis and type 1 diabetes in Sardinia. *Genes Immun* 2009; 10: 15-7.

ORIGINAL PUBLICATIONS